

MATERIAL  
 CONTACTS: COPPER ALLOY  
 INSULATOR: LCP THERMOPLASTIC 94V-0  
 WELD TAB: COPPER ALLOY

FINISH  
 CONTACTS: 5µ" MIN. GOLD ON MATING END;  
 MATTE TIN ON SOLDER  
 ALL UNDERPLATED NICKEL  
 WELD TAB: MATTE TIN

ELECTRICAL  
 CONTACT CURRENT RATING: 2 AMPERE  
 VOLTAGE RATING: 275VAC  
 MAX CYCLES: 25

ENVIRONMENT  
 OPERATION TEMPERATURE: -55°C TO 125°C  
 SMT TEMPERATURE: 260°C

THIS PRINT IS  
**PRELIMINARY**  
 UNQUALIFIED PRODUCT  
 CONTACT PRODUCT ENGINEERING  
 BEFORE USING THIS PRINT



TITLE: COM-HPC 400pin Female Connector w/ Weld Tab

DWG#: R-CF-HPC400-8AW1-NB

UNIT: mm

SCALE: A4 5:4

FINISH:

SHEET: 1/3  
 REV. REF

THIRD ANGLE PROJECTION

MATERIAL: **RoHS Compliant**

APPROVED:

TOLERANCE: Angle: ± 1°  
 X: ± 0.25 .X: ± 0.20 .XX: ± 0.15

DRAWN: Ting

DATE: 07/22/2025

A B C D E F G H

1

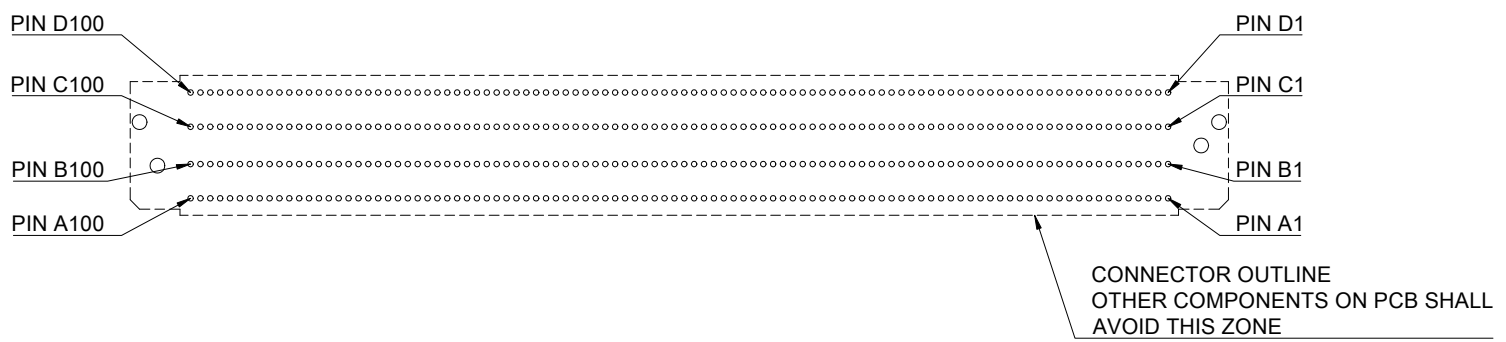

2

3

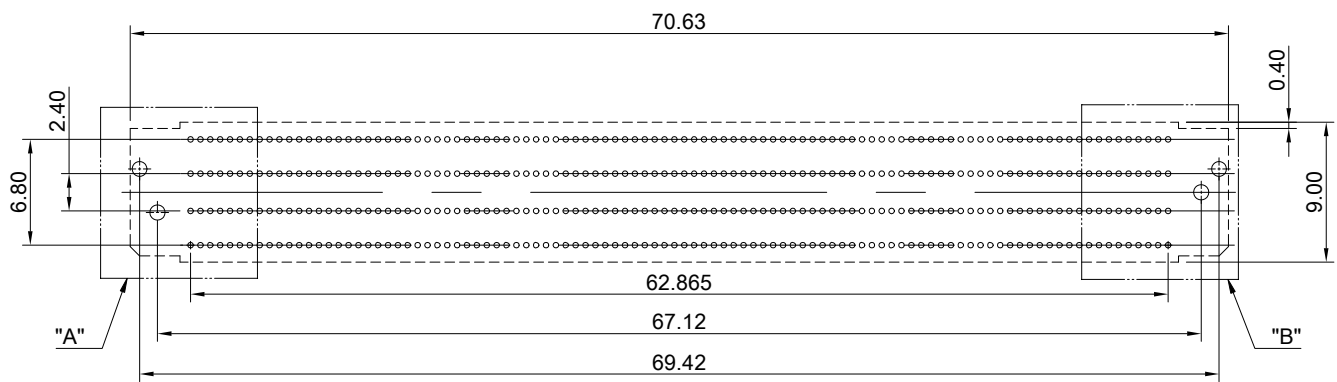

4

RECOMMENDED PCB LAYOUT  
TOLERANCE: ±0.05

5

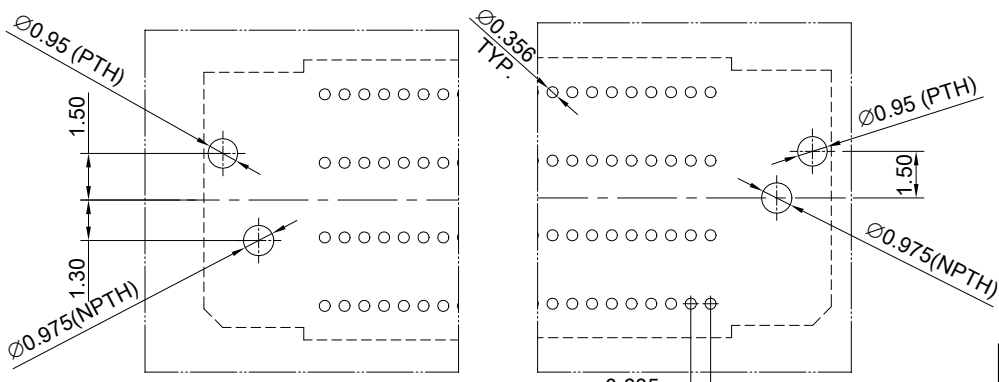

DETAIL A  
SCALE 2:1

DETAIL B  
SCALE 2:1

6

7

THIS PRINT IS  
**PRELIMINARY**  
UNQUALIFIED PRODUCT  
CONTACT PRODUCT ENGINEERING  
BEFORE USING THIS PRINT



TITLE: COM-HPC 400pin Female Connector w/ Weld Tab			
DWG#: R-CF-HPC400-8AW1-NB		SHEET: 2/3	REV. REF
UNIT: mm	SCALE: A4 2:1	FINISH:	CHECKED:
THIRD ANGLE PROJECTION		MATERIAL: RoHS Compliant	APPROVED:
TOLERANCE: Angle: ± 1° X: ± 0.15 .X: ± 0.10 .XX: ± 0.05		DRAWN: Ting	DATE: 07/22/2025

8

A B C D E F G H

FEMALE: R-CF-HPC400-8AW1-NB

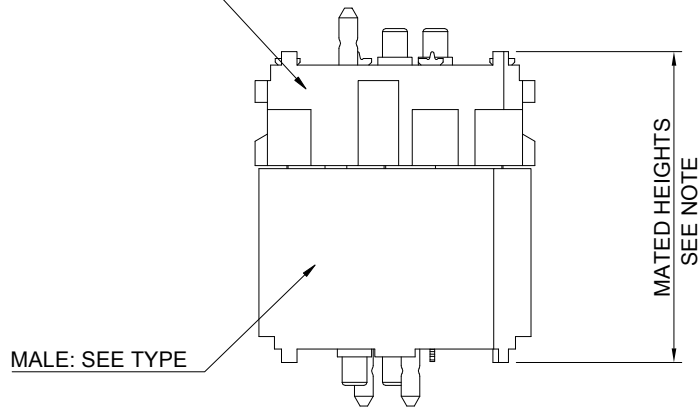

TYPE	MATED HEIGHTS
R-CM-HPC400-8AW1-NB	5mm
R-CM-HPC400-8AW2-NB	10mm

NOTE: Processing conditions will affect mated height.

PROCESSING VIEW  
 DIMENSION INDICATES CONNECTOR/FIXTURE HEIGHT ON PCB  
 TO GUARANTEE ENOUGH REFLOW OVEN WORKING SPACE.  
 DIMENSION, PCB THICKNESS, AND THE HEIGHT OF THE COMPONENTS  
 ON THE OTHER SIDE OF THE BOARD NEED TO BE CONSIDERED.

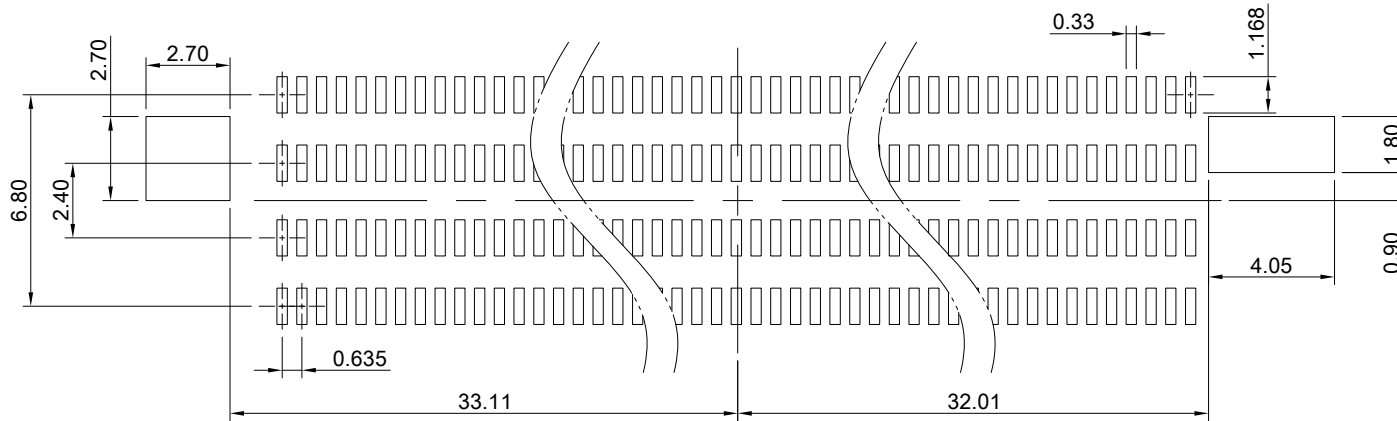

RECOMMENDED STENCIL LAYOUT  
 ALL DIMENSIONS SYMMETRIC ABOUT CENTERLINE  
 STENCIL TO BE 0.125mm THICK

THIS PRINT IS  
**PRELIMINARY**  
 UNQUALIFIED PRODUCT  
 CONTACT PRODUCT ENGINEERING  
 BEFORE USING THIS PRINT



TITLE: COM-HPC 400pin Female Connector w/ Weld Tab			
DWG#: R-CF-HPC400-8AW1-NB		SHEET: 3/3	REV. REF
UNIT: mm	SCALE: A4 4:1	CHECKED:	
THIRD ANGLE PROJECTION TOLERANCE: Angle: ± 1° X: ± 0.15 .X: ± 0.10 .XX: ± 0.05		MATERIAL: RoHS Compliant	APPROVED:
DRAWN: Ting		DATE: 07/22/2025	