

DETAIL B
SCALE 5:1

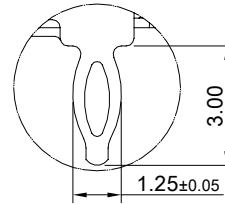

DETAIL A
SCALE 5:1

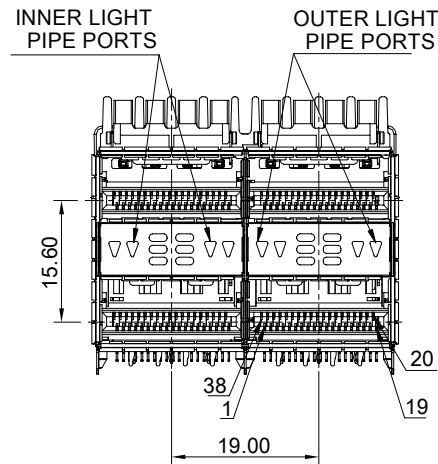
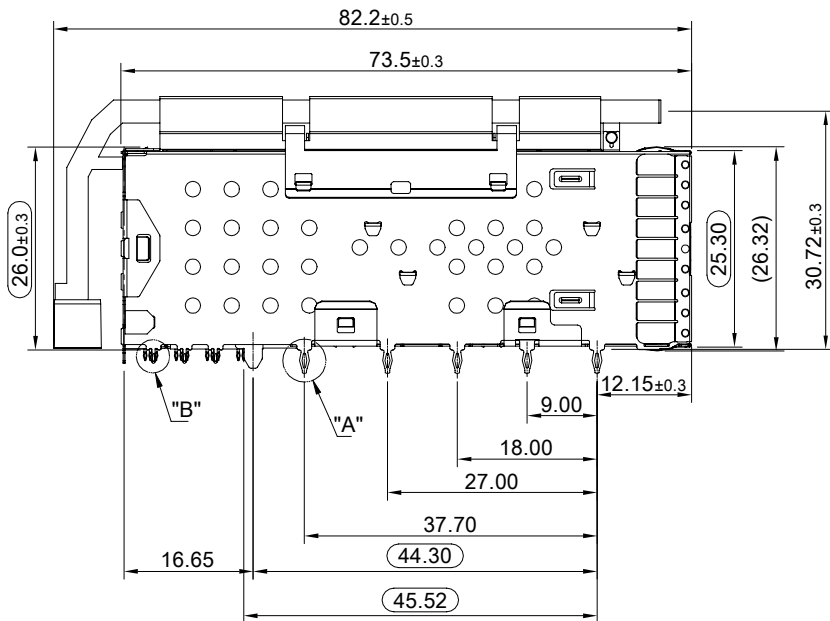
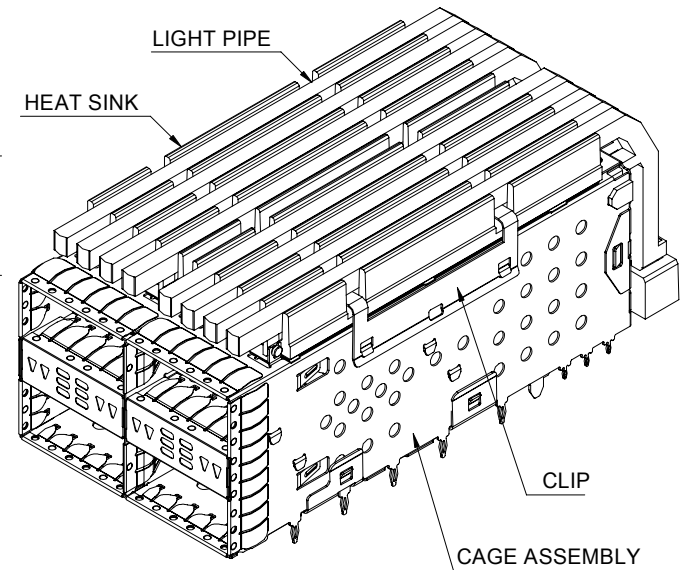

MATERIAL
 CAGE: NICKEL SILVER
 CONNECTOR HOUSING: THERMOPLASTIC, UL 94V-0(LCP)
 EMI SPRING: STAINLESS STEEL
 CONTACTS: COPPER ALLOY
 HEAT SINK: ALUMINUM
 HEAT SINK CLIP: STAINLESS STEEL
 LIGHT PIPE: PC
 LIGHT SHIELD: THERMOPLASTIC

FINISH
 HEAT SINK: ANODE PROCESS
 CONTACT: 15µ" MIN. GOLD ON MATING END;
 30µ" MIN. MATTE TIN ON TERMINAL END;
 ALL UNDERPLATED 50µ" MIN. NICKEL

ELECTRICAL CHARACTERISTICS
 CONTACT CURRENT RATING: 0.5 AMPERE
 VOLTAGE RATING: 30VAC
 CONTACT RESISTANCE: 80 mΩ MAX.
 DIELECTRIC WITHSTANDING VOLTAGE: 300VAC

THIS PRINT IS
PRELIMINARY
 UNQUALIFIED PRODUCT
 CONTACT PRODUCT ENGINEERING
 BEFORE USING THIS PRINT



TITLE: Stacked QSFP28 2x2 Assembly w/ Internal / External Heat Sink & Light Pipe			
DWG#: R-TR-ZQT2-4CMNLI-AIO-4		SHEET: 1/3	REV. REF
UNIT: mm	SCALE: A4 1:1	CHECKED:	
THIRD ANGLE PROJECTION		APPROVED:	
TOLERANCE: Angle: ± 1°		MATERIAL: RoHS Compliant	DATE: 03/20/2024
X.± 0.25 .X± 0.20 .XX± 0.15		DRAWN: Yilu	

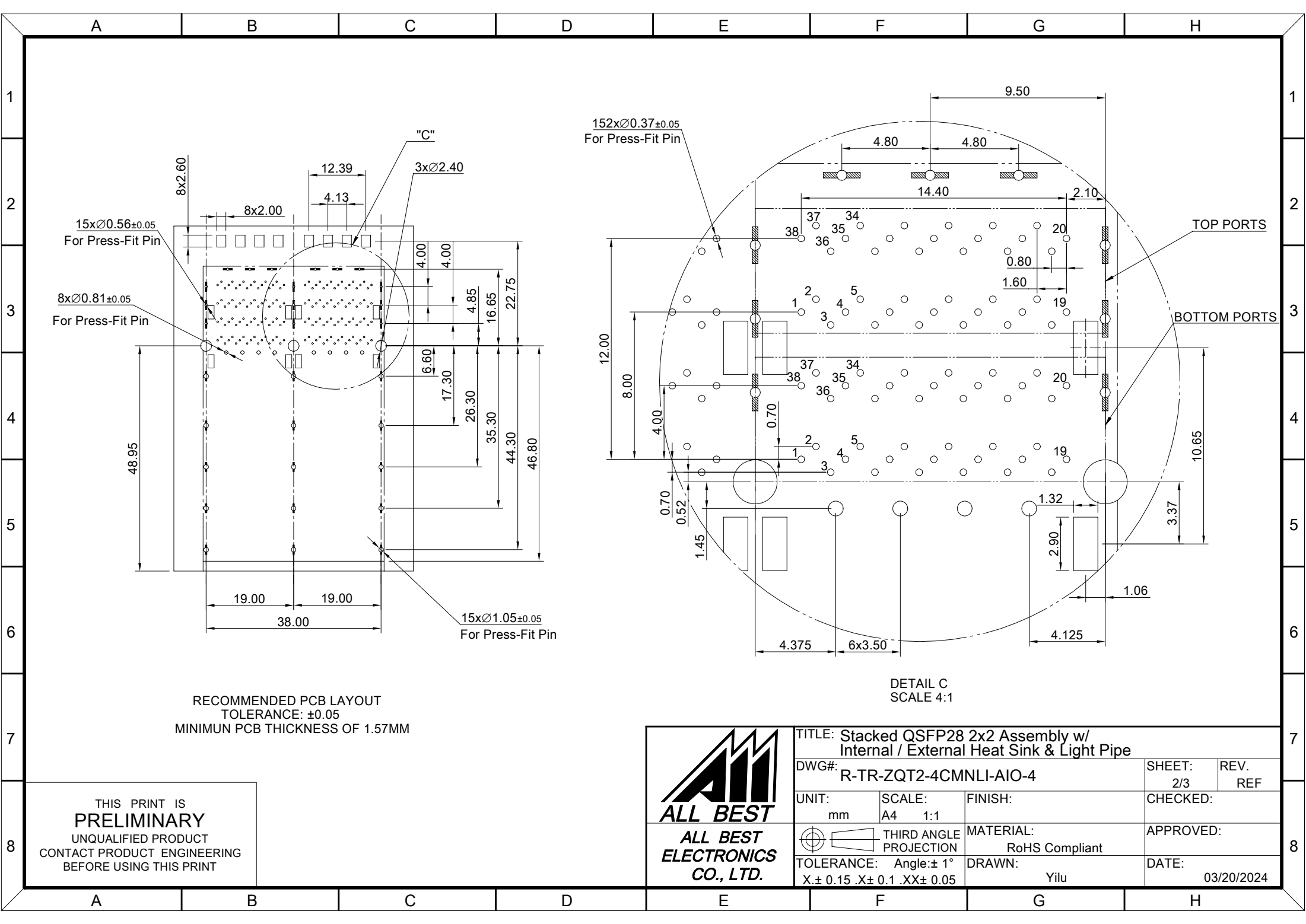

RECOMMENDED PCB LAYOUT
 TOLERANCE: ± 0.05
 MINIMUM PCB THICKNESS OF 1.57MM

DETAIL C
 SCALE 4:1

THIS PRINT IS
PRELIMINARY
 UNQUALIFIED PRODUCT
 CONTACT PRODUCT ENGINEERING
 BEFORE USING THIS PRINT



TITLE: Stacked QSFP28 2x2 Assembly w/ Internal / External Heat Sink & Light Pipe			
DWG#: R-TR-ZQT2-4CMNLI-AIO-4		SHEET: 2/3	REV. REF
UNIT: mm	SCALE: A4 1:1	FINISH:	CHECKED:
THIRD ANGLE PROJECTION		MATERIAL: RoHS Compliant	APPROVED:
TOLERANCE: Angle: $\pm 1^\circ$ $X \pm 0.15$. $X \pm 0.1$. $XX \pm 0.05$		DRAWN: Yilu	DATE: 03/20/2024

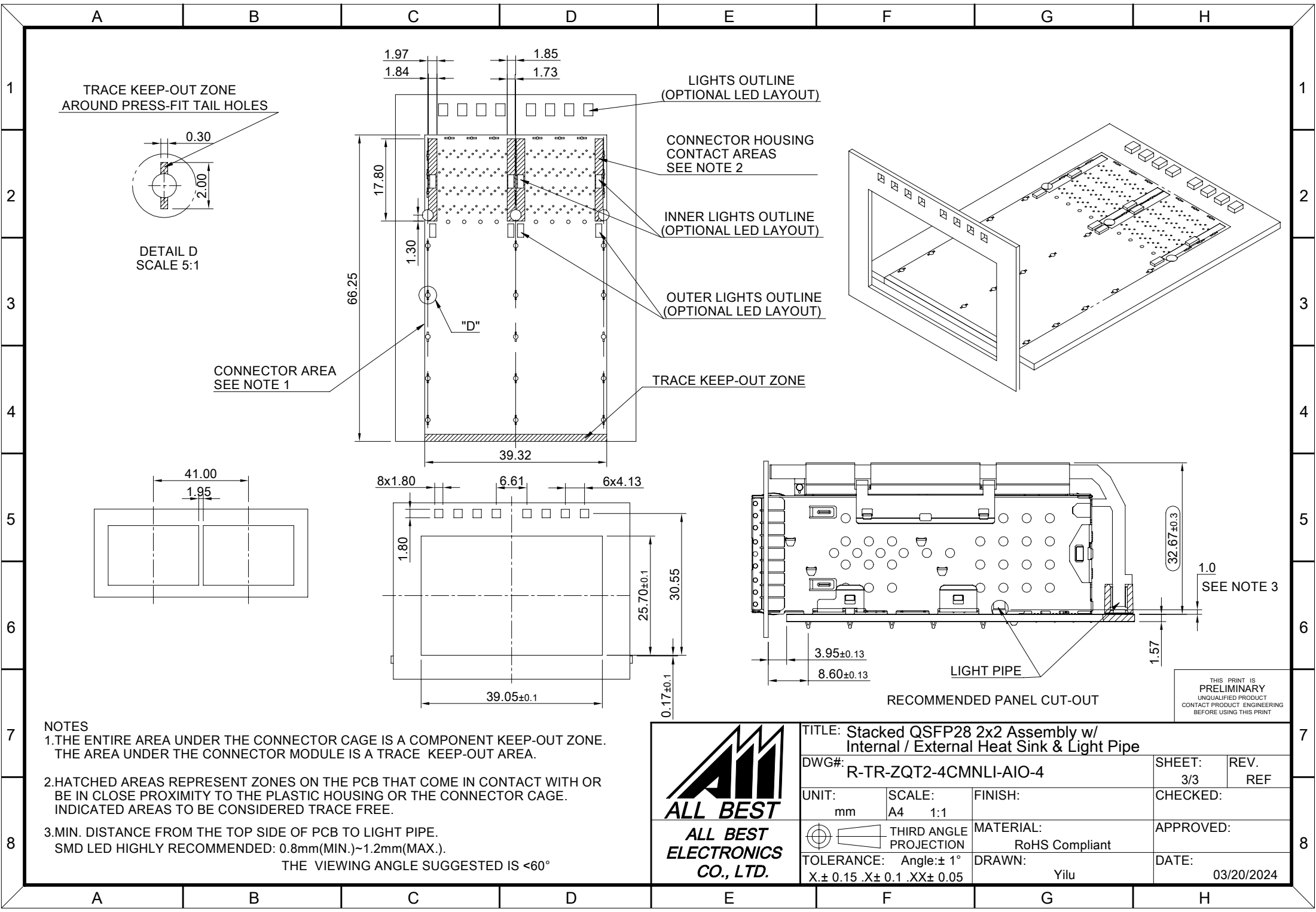

NOTES

1. THE ENTIRE AREA UNDER THE CONNECTOR CAGE IS A COMPONENT KEEP-OUT ZONE. THE AREA UNDER THE CONNECTOR MODULE IS A TRACE KEEP-OUT AREA.
2. HATCHED AREAS REPRESENT ZONES ON THE PCB THAT COME IN CONTACT WITH OR BE IN CLOSE PROXIMITY TO THE PLASTIC HOUSING OR THE CONNECTOR CAGE. INDICATED AREAS TO BE CONSIDERED TRACE FREE.
3. MIN. DISTANCE FROM THE TOP SIDE OF PCB TO LIGHT PIPE.
SMD LED HIGHLY RECOMMENDED: 0.8mm(MIN.)~1.2mm(MAX.).
THE VIEWING ANGLE SUGGESTED IS <60°

THIS PRINT IS
PRELIMINARY
UNQUALIFIED PRODUCT
CONTACT PRODUCT ENGINEERING
BEFORE USING THIS PRINT

<p>ALL BEST ELECTRONICS CO., LTD.</p>	TITLE: Stacked QSFP28 2x2 Assembly w/ Internal / External Heat Sink & Light Pipe		SHEET: 3/3		REV. REF
	DWG#: R-TR-ZQT2-4CMNLI-AIO-4		CHECKED:		APPROVED:
	UNIT: mm	SCALE: A4 1:1	FINISH:	MATERIAL: RoHS Compliant	
	TOLERANCE: X±0.15 .X±0.1 .XX±0.05		THIRD ANGLE PROJECTION	DRAWN: Yilu	DATE: 03/20/2024