

DETAIL A
SCALE 4:1

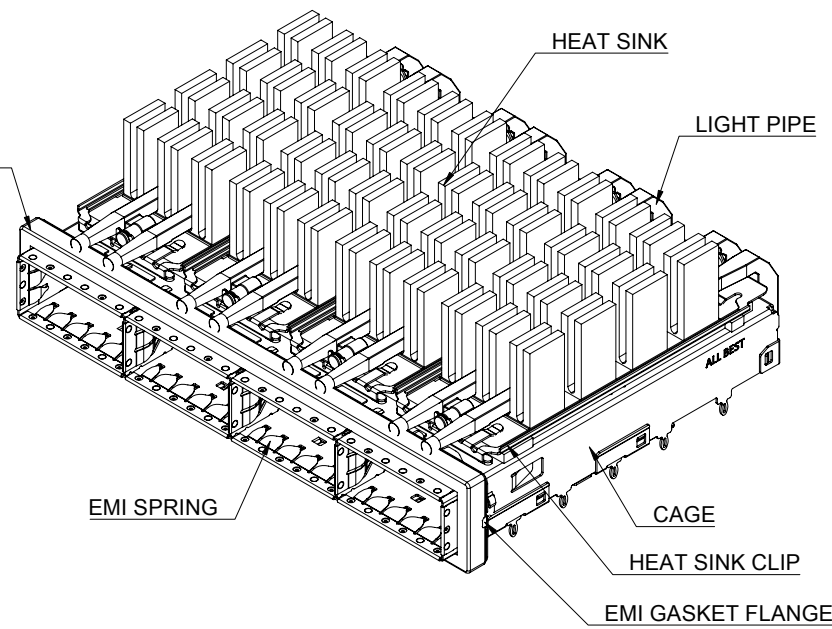
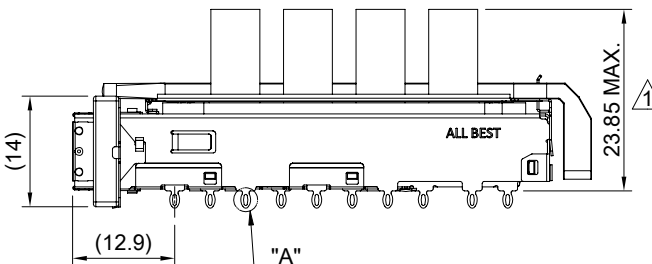

- MATERIAL
 CAGE: NICKEL SILVER
 HEAT SINK: ALUMINUM
 HEAT SINK CLIP: STAINLESS STEEL
 EMI SPRING: STAINLESS STEEL
 EMI GASKET: CONDUCTIVE ELASTOMER
 EMI GASKET FLANGE: STAINLESS STEEL
 LIGHT PIPE: PC

- FINISH
 HEAT SINK: ANODE PROCESS

NOTE
 ⚠ DIMENSION APPLIES WITH MODULE INSERTED IN CAGE



TITLE: QSFP28 1X4 Cage Assembly w/ NET Heat Sink & Light Pipe			
DWG#: R-OR-ZQ4-4CGED-MK		SHEET: 1/4	REV. B
UNIT: mm	SCALE: A4 1:1	CHECKED: Gary Kang	
THIRD ANGLE PROJECTION		APPROVED: George Yang	
TOLERANCE: Angle: ± 1° X ± 0.25 .X ± 0.20 .XX ± 0.15		DRAWN: Jason Zhao	DATE: 09/22/2021

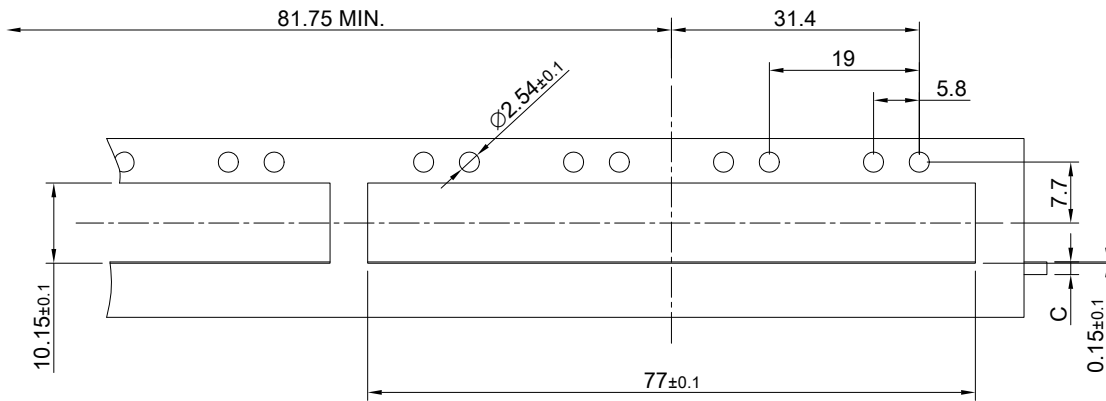

SINGLE-SIDE CONFIGURATION

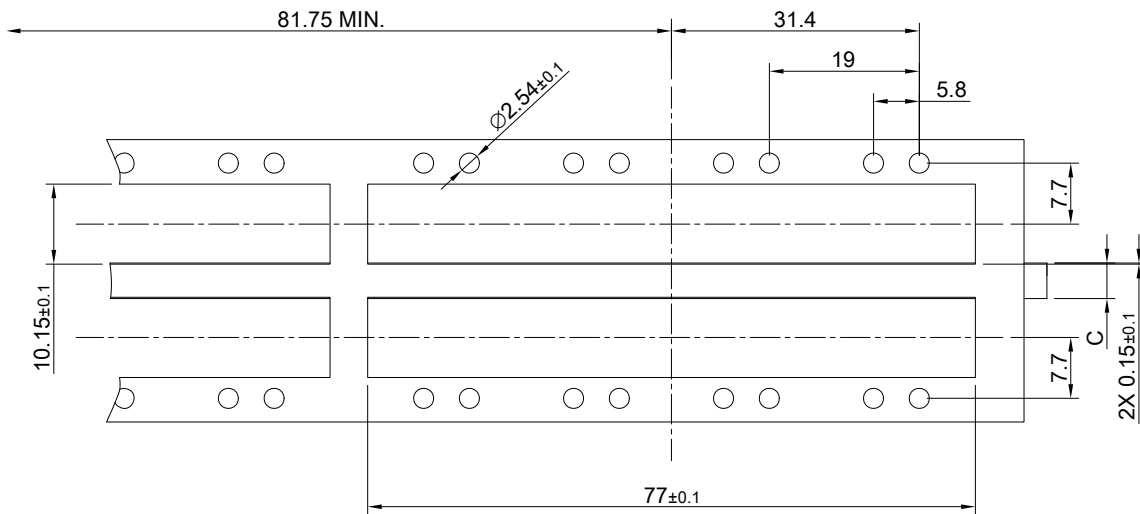
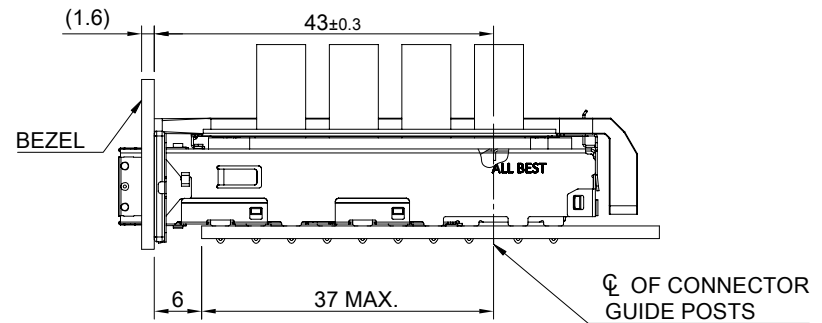

BELLY TO BELLY CONFIGURATION

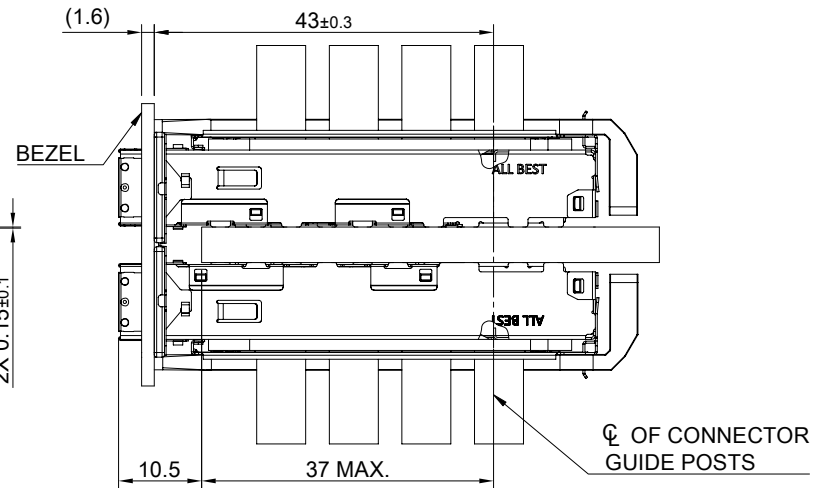

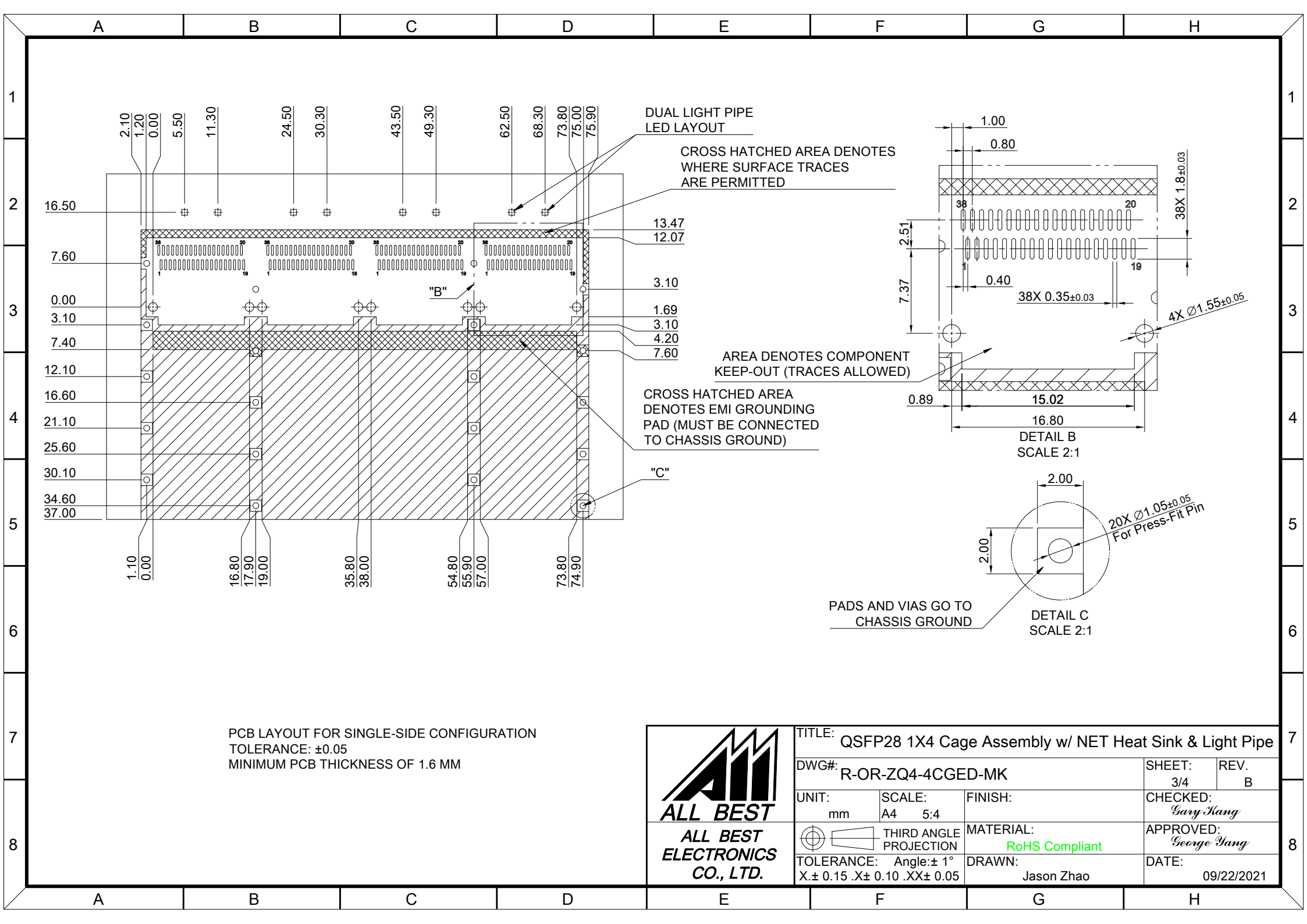

C = THICKNESS OF PC BOARD
 SINGLE-SIDE = 1.6MM (MIN.)
 BELLY TO BELLY = 4.5MM (MIN.)

 ALL BEST ELECTRONICS CO., LTD.	TITLE: QSFP28 1X4 Cage Assembly w/ NET Heat Sink & Light Pipe		SHEET: 2/4	REV. B
	DWG#: R-OR-ZQ4-4CGED-MK		CHECKED: Gary Kang	
UNIT: mm	SCALE: A4 1:1	FINISH:	APPROVED: George Yang	
TOLERANCE: Angle: ± 1°		MATERIAL: RoHS Compliant	DATE: 09/22/2021	
THIRD ANGLE PROJECTION		DRAWN: Jason Zhao		
X ± 0.15 .X ± 0.10 .XX ± 0.05				



PCB LAYOUT FOR SINGLE-SIDE CONFIGURATION
 TOLERANCE: ± 0.05
 MINIMUM PCB THICKNESS OF 1.6 MM

 ALL BEST ELECTRONICS CO., LTD.		TITLE: QSFP28 1X4 Cage Assembly w/ NET Heat Sink & Light Pipe	
		DWG#: R-OR-ZQ4-4CGED-MK	
UNIT: mm	SCALE: A4 5:4	FINISH:	SHEET: 3/4
 THIRD ANGLE PROJECTION		MATERIAL: RoHS Compliant	REV: B
TOLERANCE: Angle: $\pm 1^\circ$ X: ± 0.15 .X: ± 0.10 .XX: ± 0.05		DRAWN: Jason Zhao	CHECKED: <i>Gary Kang</i>
		DATE: 09/22/2021	APPROVED: <i>George Yang</i>

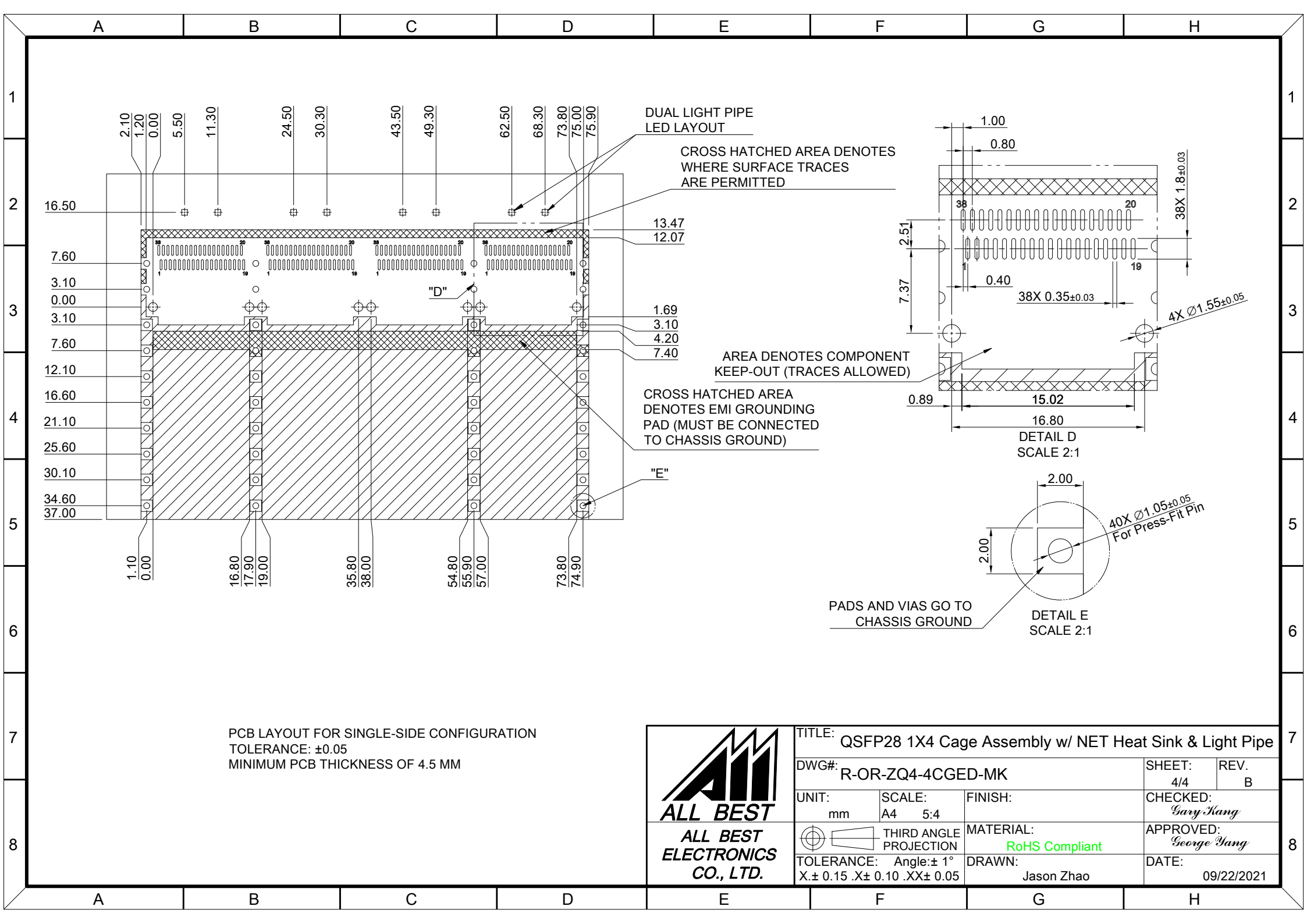

PCB LAYOUT FOR SINGLE-SIDE CONFIGURATION
 TOLERANCE: ±0.05
 MINIMUM PCB THICKNESS OF 4.5 MM

 ALL BEST ELECTRONICS CO., LTD.	TITLE: QSFP28 1X4 Cage Assembly w/ NET Heat Sink & Light Pipe		SHEET: 4/4		REV. B
	DWG#: R-OR-ZQ4-4CGED-MK		CHECKED: Gary Kang		APPROVED: George Yang
UNIT: mm	SCALE: A4 5:4	FINISH:		DRAWN: Jason Zhao	
TOLERANCE: Angle: ± 1° X. ± 0.15 .X ± 0.10 .XX ± 0.05		MATERIAL: RoHS Compliant		DATE: 09/22/2021	