

DETAIL A
SCALE 5:1

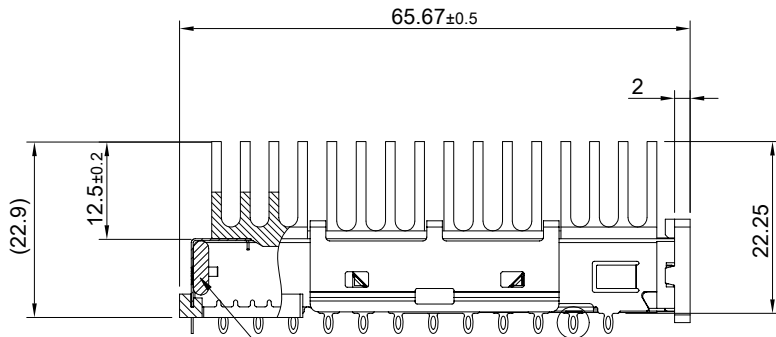

REAR EMI GASKET

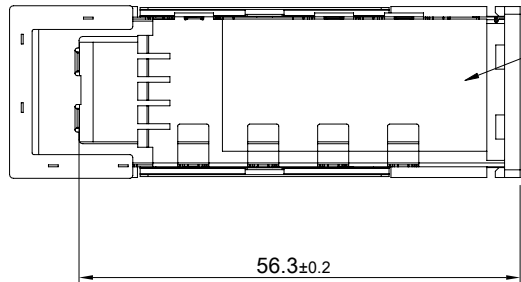
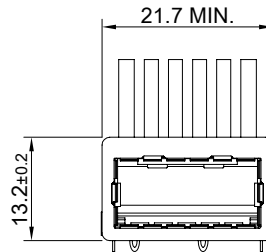

INSULATION TAPE
17mm (H)X 34mm(W) X 0.2(T)

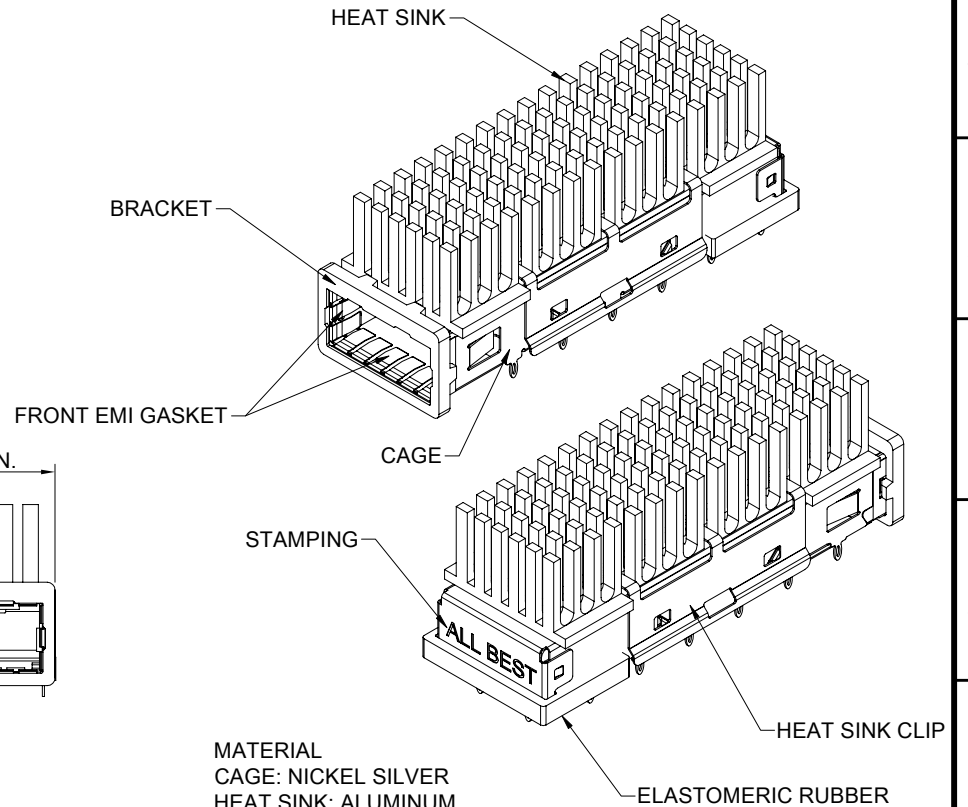

MATERIAL
 CAGE: NICKEL SILVER
 HEAT SINK: ALUMINUM
 HEAT SINK CLIP: STAINLESS STEEL
 FRONT EMI GASKET: COPPER ALLOY
 REAR EMI GASKET: CONDUCTIVE FOAM
 ELASTOMERIC RUBBER: CONDUCTIVE RUBBER
 BRACKET: ZINC ALLOY
 INSULATION TAPE: PET

FINISH
 HEAT SINK: ANODE PROCESS
 FRONT EMI GASKET: TIN OVER COPPER
 BRACKET: TIN



TITLE: XFP Cage Assembly With Heat Sink 12.5mm Tall			
DWG#: R-CG-008030-27		SHEET: 1 / 2	REV. B
UNIT: mm	SCALE: A4 1:1	FINISH:	CHECKED: Sheng Wu
THIRD ANGLE PROJECTION		MATERIAL: RoHS Compliant	APPROVED: George Yang
TOLERANCE: Angle: ± 1° X ± 0.25 .X ± 0.2 .XX ± 0.15		DRAWN: Yilu	DATE: 10/17/2019

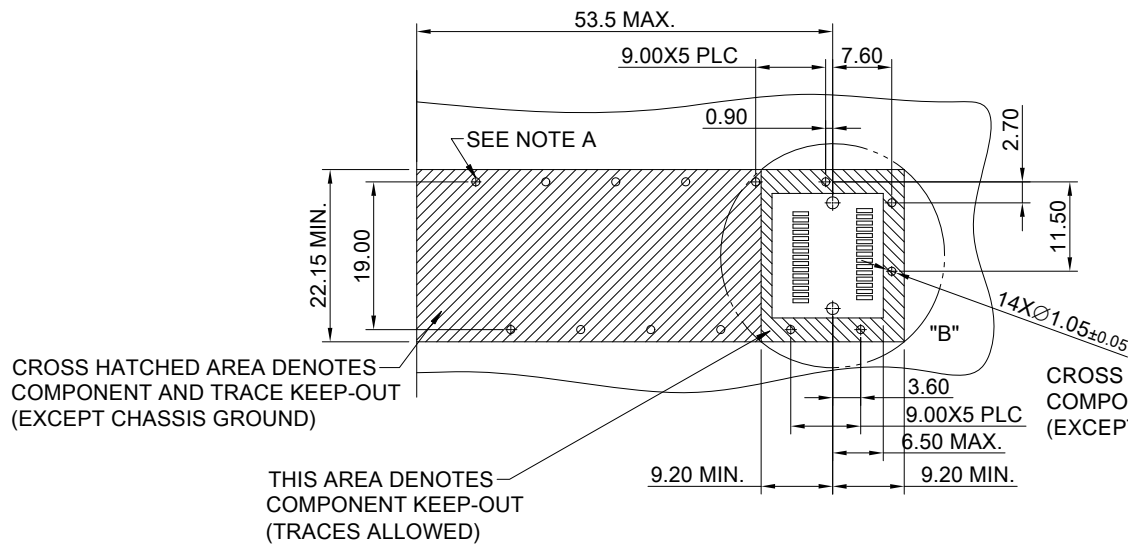

DETAILED HOST BOARD MECHANICAL LAYOUT
TOLERANCE: ±0.05

- NOTE A: RECOMMENDATION FOR P.C.B. HOLES
1. HOLE Ø AFTER DRILLING: 1.15±0.02
 2. HOLE Ø AFTER TIN LEAD PLATED: 1.05±0.05
 3. 25µm-50µm COPPER UNDERPLATED
 4. MAXIMUM 35µm Sn PLATING

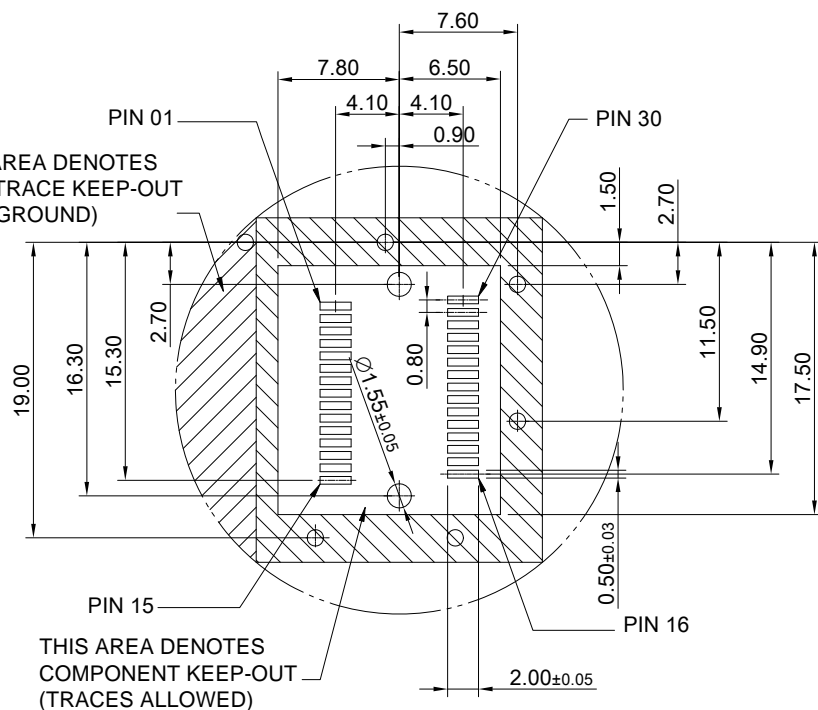
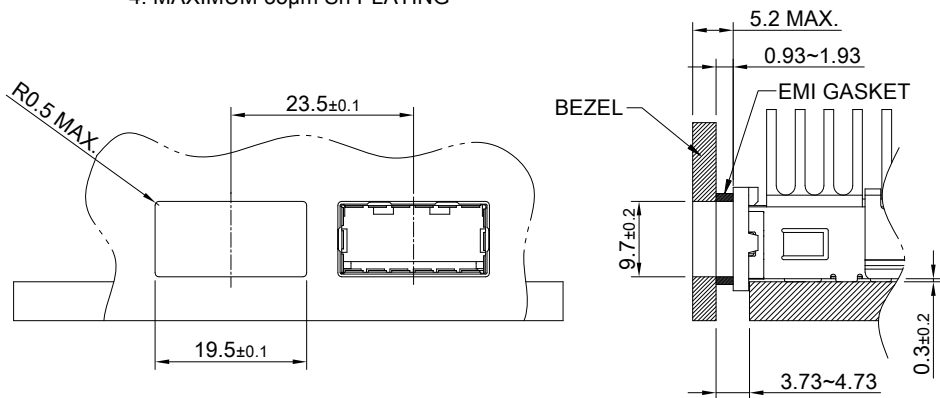

DETAILED HOST BOARD MECHANICAL LAYOUT
TOLERANCE: ±0.05

DETAIL B
SCALE 2:1



TITLE: XFP Cage Assembly With Heat Sink 12.5mm Tall			
DWG#: R-CG-008030-27		SHEET: 2/2	REV. B
UNIT: mm	SCALE: A4 1:1	FINISH:	CHECKED: <i>Sheng Wu</i>
THIRD ANGLE PROJECTION		MATERIAL: RoHS Compliant	APPROVED: <i>George Yang</i>
TOLERANCE: Angle: ±1° X±0.15 .X±0.1 .XX±0.05		DRAWN: Yilu	DATE: 10/17/2019