

DETAIL A
SCALE 5:1

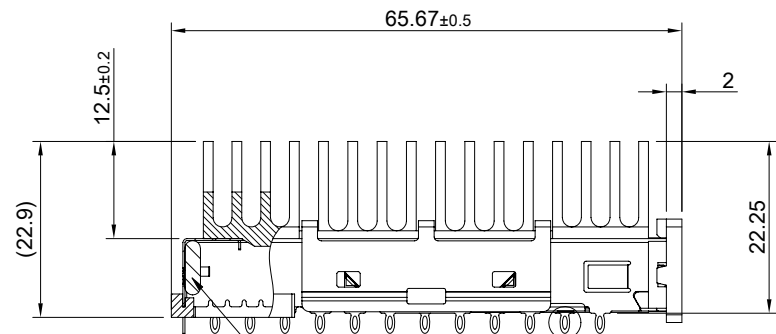

REAR EMI GASKET

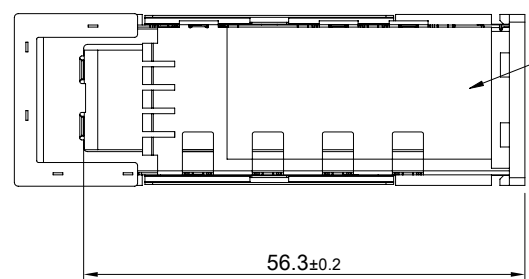
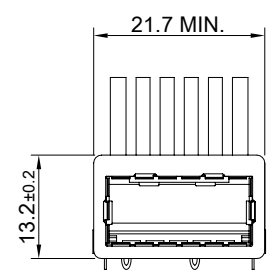

INSULATION TAPE
17mm (H)X 34mm(W) X 0.2(T)

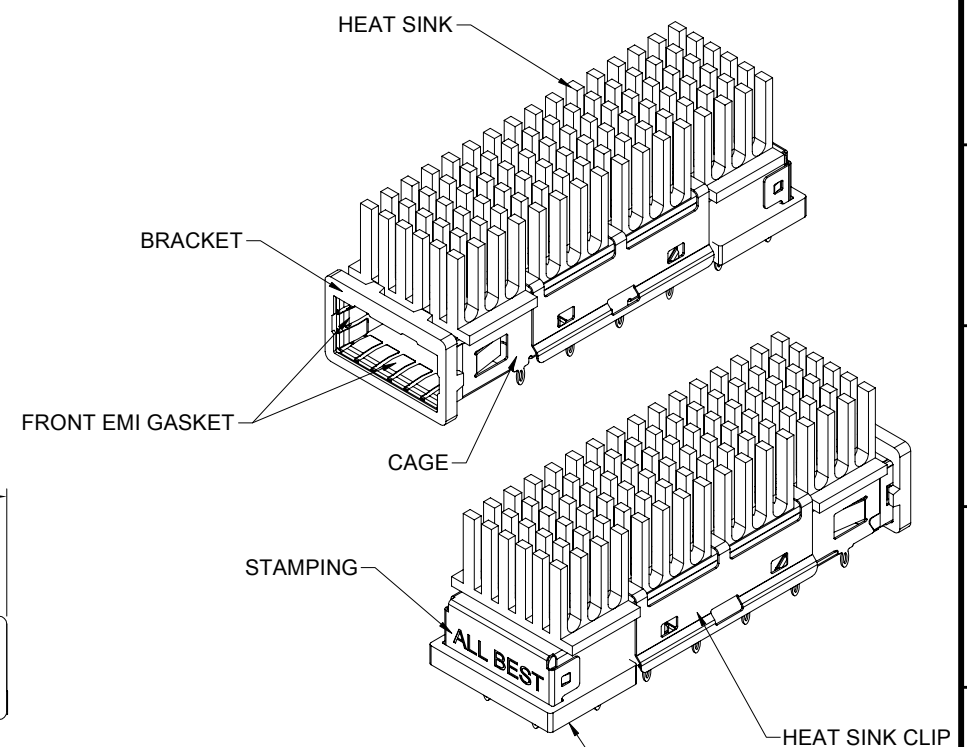

MATERIAL
 CAGE: NICKEL SILVER
 HEAT SINK: ALUMINUM
 HEAT SINK CLIP: STAINLESS STEEL
 FRONT EMI GASKET: COPPER ALLOY
 REAR EMI GASKET: CONDUCTIVE FOAM
 ELASTOMERIC RUBBER: CONDUCTIVE RUBBER
 BRACKET: ZINC ALLOY
 INSULATION TAPE: PET

FINISH
 HEAT SINK: ANODE PROCESS
 FRONT EMI GASKET: TIN OVER COPPER
 BRACKET: TIN

 ALL BEST ELECTRONICS CO., LTD.	TITLE: XFP Cage Assembly		SHEET: 1 / 2	REV. F
	DWG#: R-CG-008030-10		CHECKED: <i>Sheng Wu</i>	
	UNIT: mm	SCALE: A4 1:1	FINISH:	APPROVED: <i>George Yang</i>
	TOLERANCE: X±0.25 .X±0.2 .XX±0.15		MATERIAL: RoHS Compliant	DATE: 10/17/2019
THIRD ANGLE PROJECTION		DRAWN: Yilu		

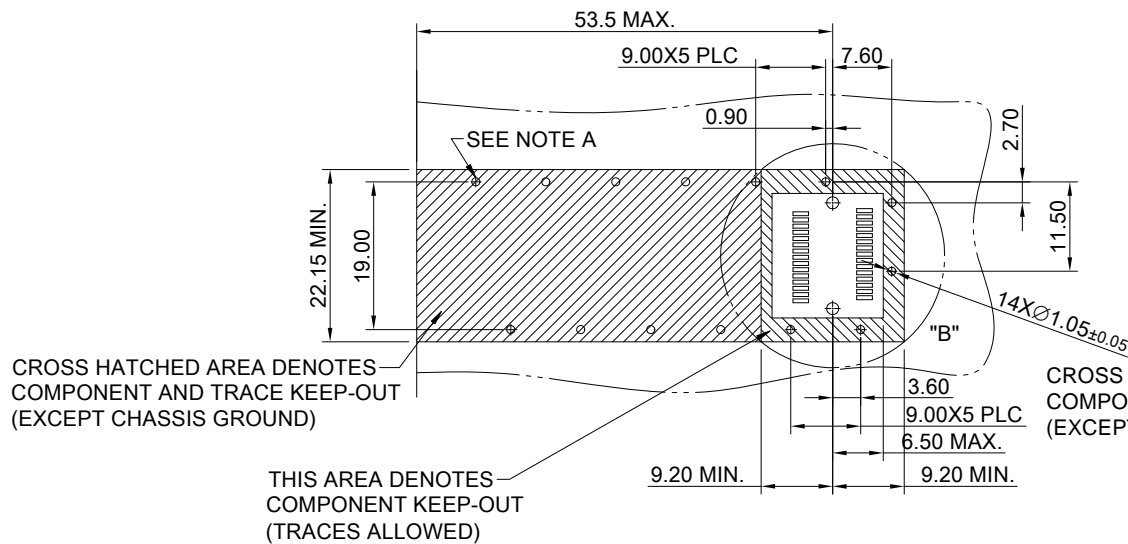

DETAILED HOST BOARD MECHANICAL LAYOUT
TOLERANCE: ± 0.05

- NOTE A: RECOMMENDATION FOR P.C.B. HOLES
1. HOLE \varnothing AFTER DRILLING: 1.15 ± 0.02
 2. HOLE \varnothing AFTER TIN LEAD PLATED: 1.05 ± 0.05
 3. 25 μ m-50 μ m COPPER UNDERPLATED
 4. MAXIMUM 35 μ m Sn PLATING

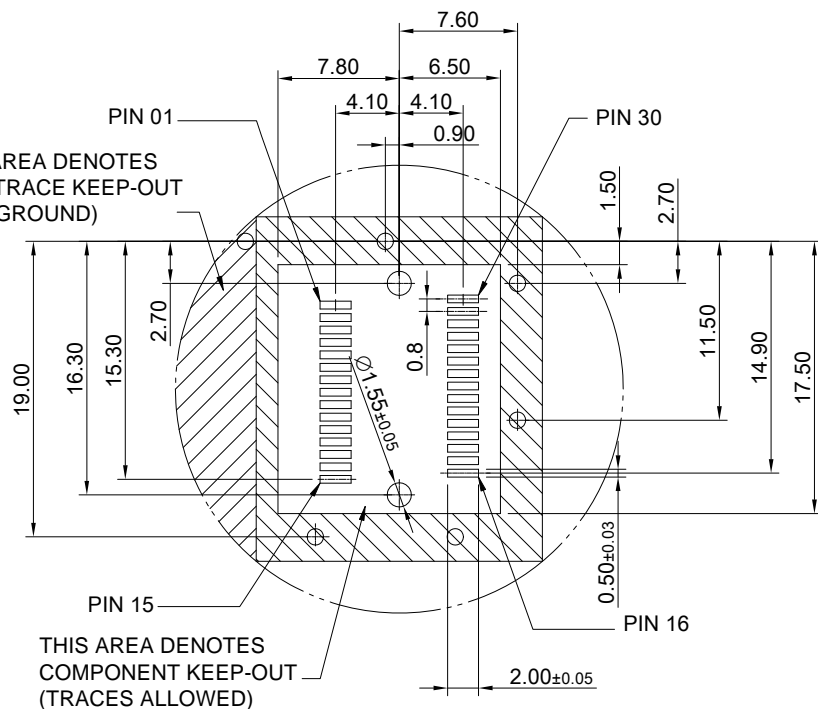
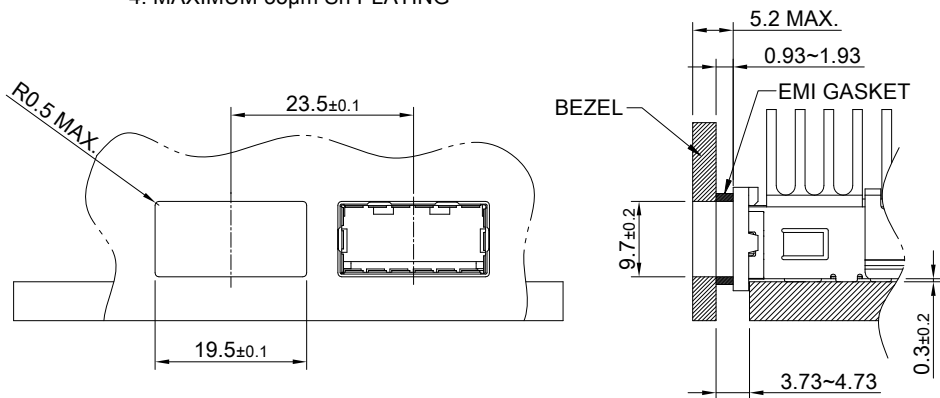

DETAILED HOST BOARD MECHANICAL LAYOUT
TOLERANCE: ± 0.05

DETAIL B
SCALE 2:1

<p>ALL BEST ALL BEST ELECTRONICS CO., LTD.</p>	TITLE: XFP Cage Assembly		SHEET: 2/2	REV. F
	DWG#: R-CG-008030-10		CHECKED: <i>Sheng Wu</i>	
	UNIT: mm	SCALE: A4 1:1	FINISH:	APPROVED: <i>George Yang</i>
	TOLERANCE: Angle: $\pm 1^\circ$ X ± 0.15 .X ± 0.1 .XX ± 0.05		MATERIAL: RoHS Compliant	DATE: 10/17/2019