

DETAIL A  
SCALE: 5:1

DETAIL B  
SCALE: 5:1

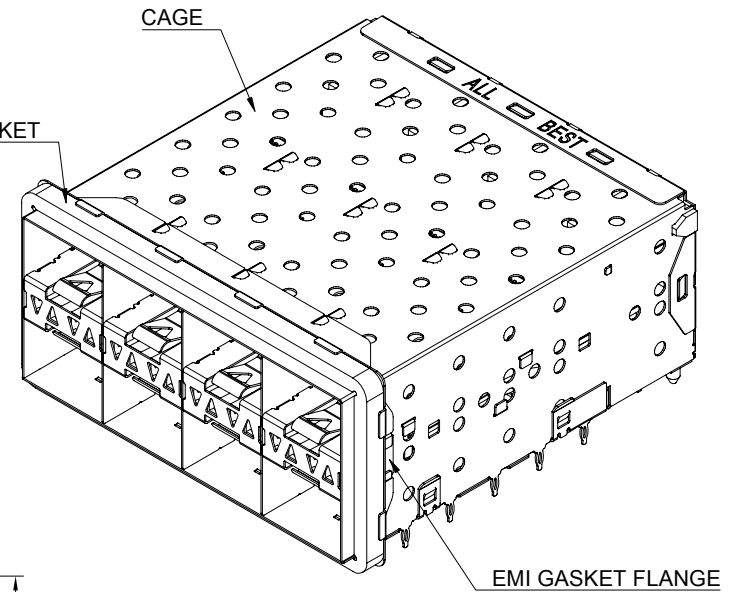

EMI GASKET FLANGE

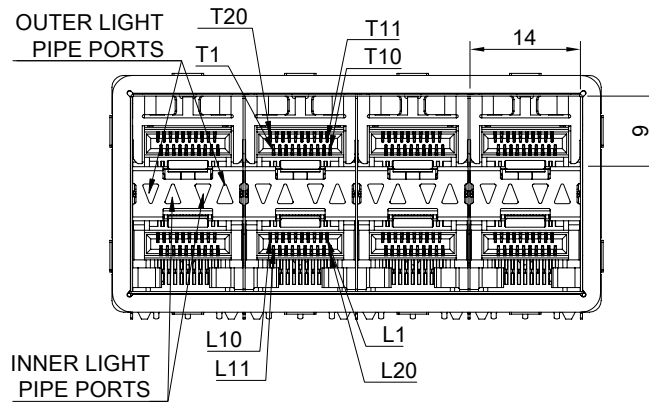
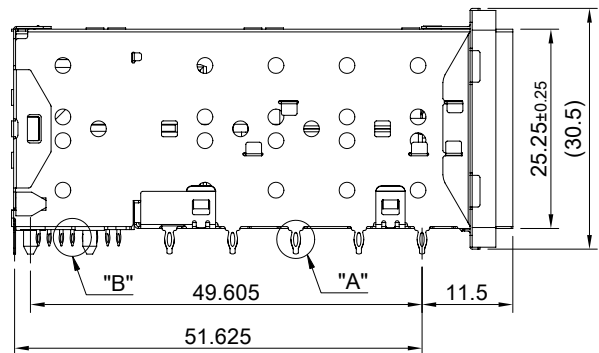

**MATERIAL**

CAGE: NICKEL SILVER  
CONNECTOR: LCP 94V-0  
COPPER ALLOY

EMI GASKET FLANGE: NICKEL SILVER  
EMI GASKET: CONDUCTIVE ELASTOMER, (BLACK)  
LIGHT PIPE: PC

**FINISH**

CONTACT: 15μ" MIN. GOLD ON MATING END;  
30μ" MIN. MATTE TIN ON TERMINATION END;  
ALL UNDERPLATED 50μ" MIN. NICKEL

**ELECTRICAL CHARACTERISTICS**

CONTACT CURRENT RATING: 0.5 AMPERE  
VOLTAGE RATING: 30 VAC  
CONTACT RESISTANCE: 80 mΩ MAX  
DIELECTRIC WITHSTANDING VOLTAGE: 300 VAC

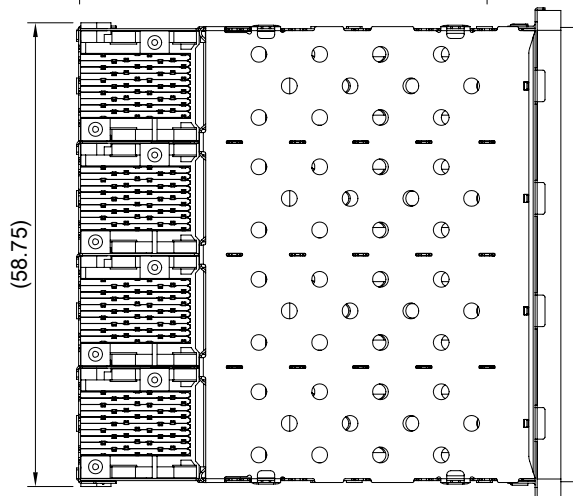

THIS PRINT IS  
**PRELIMINARY**  
UNQUALIFIED PRODUCT  
CONTACT PRODUCT ENGINEERING  
BEFORE USING THIS PRINT



TITLE: Stacked SFP+ 2x4 ASS'Y w/ Internal Thermal Solution & Light Pipe

DWG#: R-OP-008160-7-F-N2-06

SHEET: 1/3  
REV. REF

UNIT: mm

SCALE: A4 1:1

FINISH:

CHECKED:

THIRD ANGLE PROJECTION

MATERIAL: RoHS Compliant

APPROVED:

TOLERANCE: Angle: ± 1°  
X ± 0.15 .X ± 0.10 .XX ± 0.05

DRAWN: Laura

DATE: 03/22/2024

THIS PRINT IS  
**PRELIMINARY**  
 UNQUALIFIED PRODUCT  
 CONTACT PRODUCT ENGINEERING  
 BEFORE USING THIS PRINT

37x $\varnothing$ 1.05 $\pm$ 0.05  
 For Press-Fit Pin

CROSS HATCHED AREA DENOTES EMI  
 GROUNDING PAD (MUST BE CONNECTED)  
 TO CHASSIS GROUND

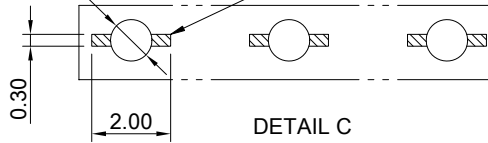

DETAIL C  
 SCALE 4:1

SEE CONNECTOR  
 PIN-OUT

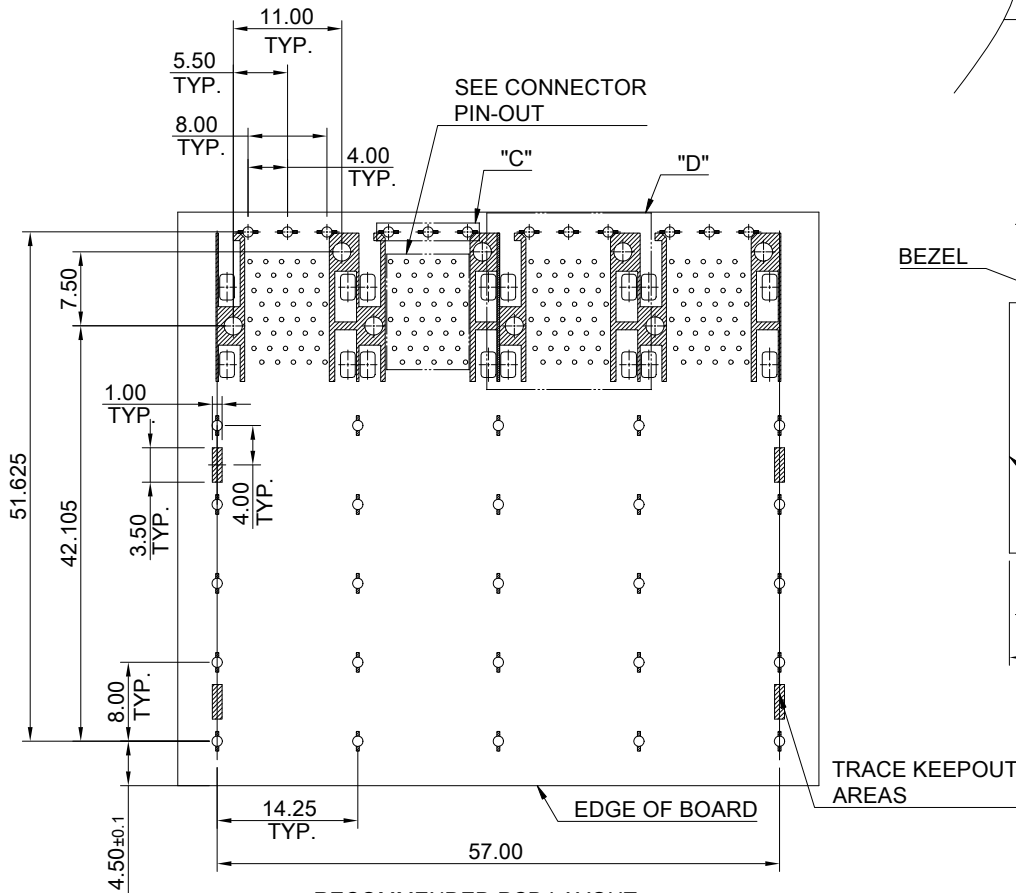

RECOMMENDED PCB LAYOUT  
 TOLERANCE:  $\pm$ 0.05  
 MINIMUM PCB THICKNESS OF 1.57MM

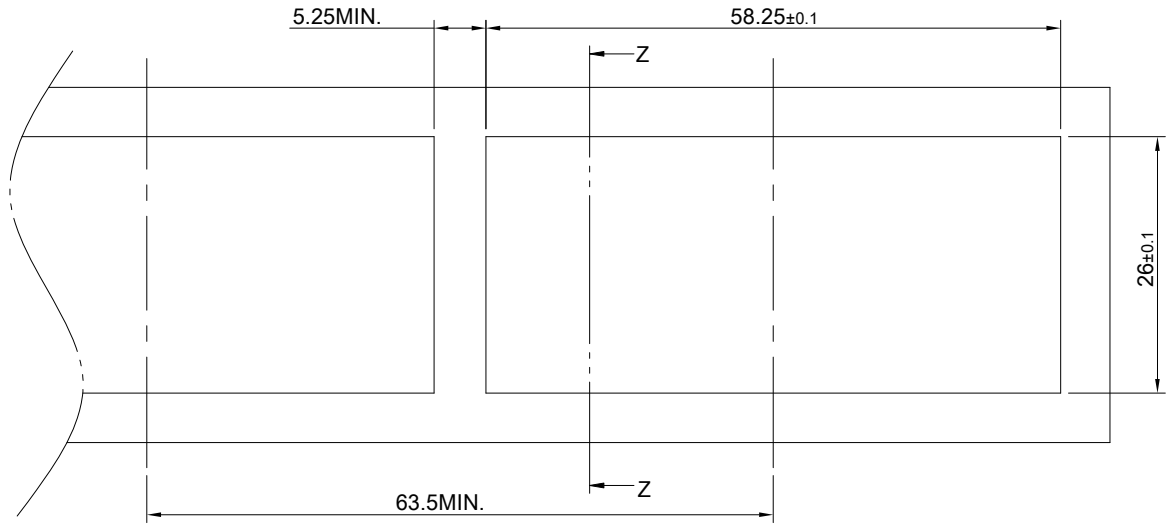

RECOMMENDED CUT-OUT SPACING DETAIL  
 BEZEL THICKNESS 0.8~2.6MM

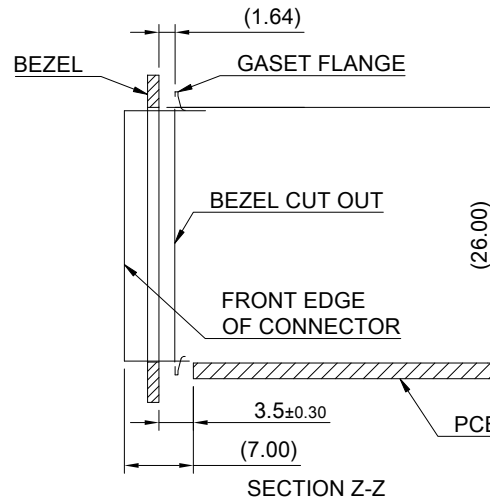

SECTION Z-Z

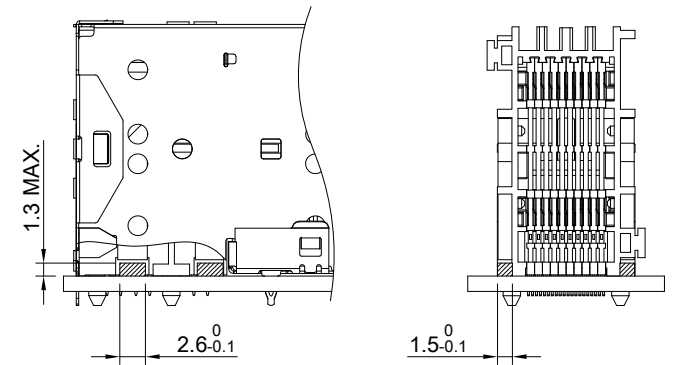

LED CLEARANCE REQUIREMENTS



TITLE: Stacked SFP+ 2x4 ASS'Y w/ Internal Thermal Solution & Light Pipe			
DWG#: R-OP-008160-7-F-N2-06		SHEET: 2/3	REV. REF
UNIT: mm	SCALE: A4 5:4	FINISH:	
TOLERANCE: Angle: $\pm$ 1° X. $\pm$ 0.15 .X $\pm$ 0.10 .XX $\pm$ 0.05		MATERIAL: RoHS Compliant	APPROVED:
DRAWN: Laura		DATE: 03/22/2024	

A B C D E F G H

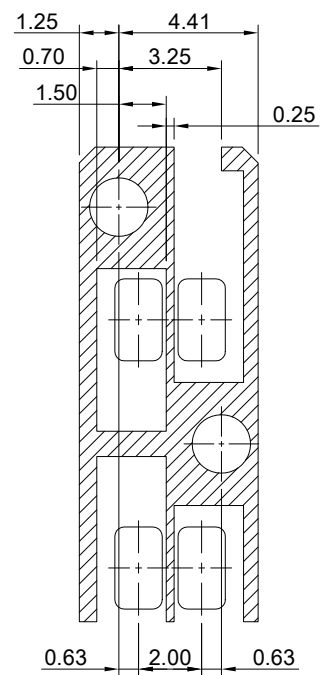
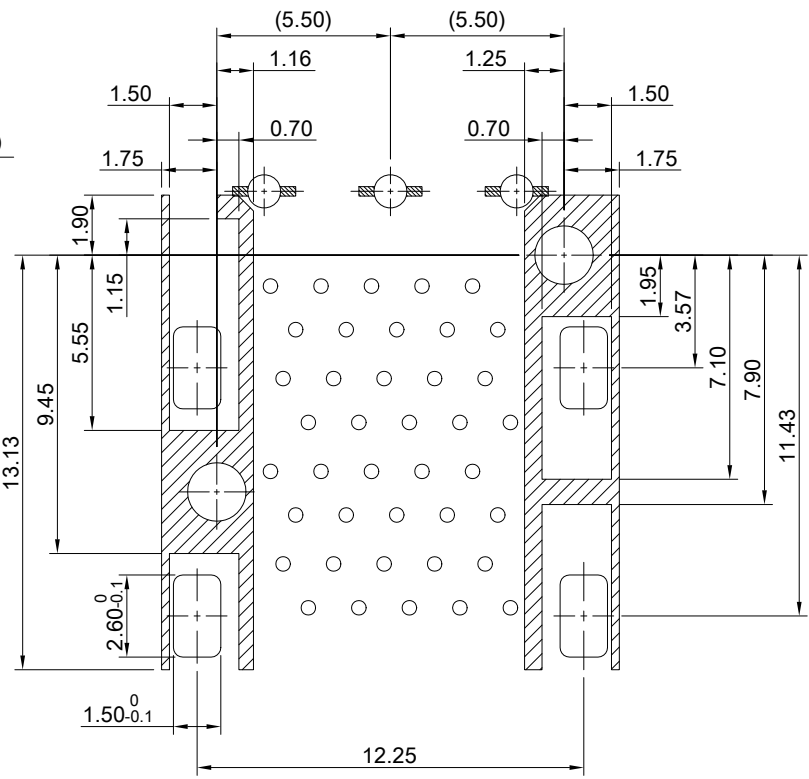
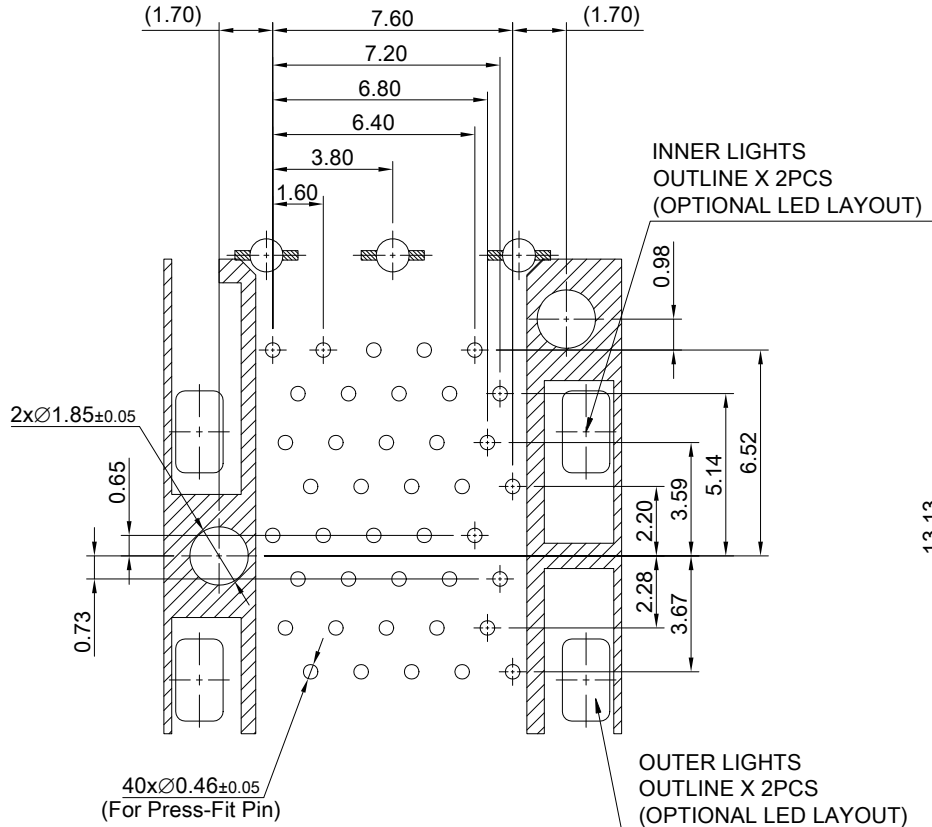

DETAIL D  
TOLERANCE: ±0.05

KEEPOUT ZONE DETAIL

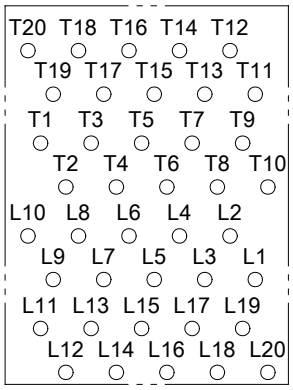

CONNECTOR PIN OUT

THIS PRINT IS  
**PRELIMINARY**  
UNQUALIFIED PRODUCT  
CONTACT PRODUCT ENGINEERING  
BEFORE USING THIS PRINT



TITLE: Stacked SFP+ 2x4 ASS'Y w/ Internal Thermal Solution & Light Pipe			
DWG#: R-OP-008160-7-F-N2-06		SHEET: 3/3	REV. REF
UNIT: mm	SCALE: A4 4:1	FINISH:	CHECKED:
TOLERANCE: Angle: ± 1° X.± 0.15 .X± 0.10 .XX± 0.05		MATERIAL: RoHS Compliant	APPROVED:
THIRD ANGLE PROJECTION		DRAWN: Laura	DATE: 03/22/2024