

DETAIL A
SCALE 5:1

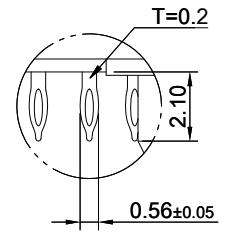

DETAIL B
SCALE 5:1

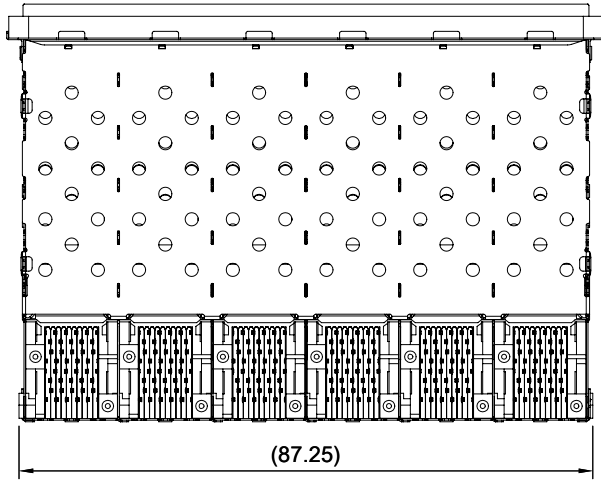
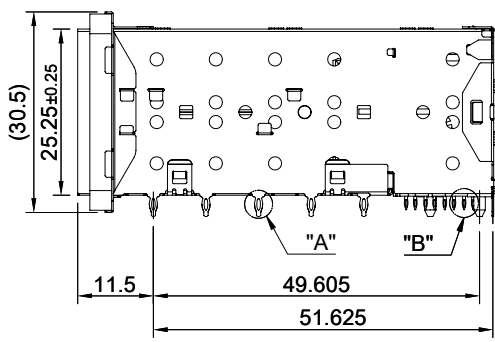
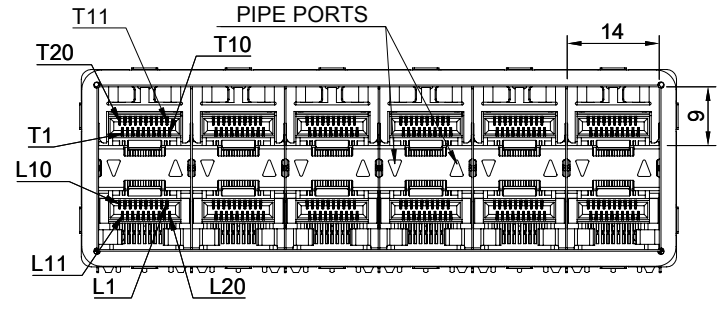
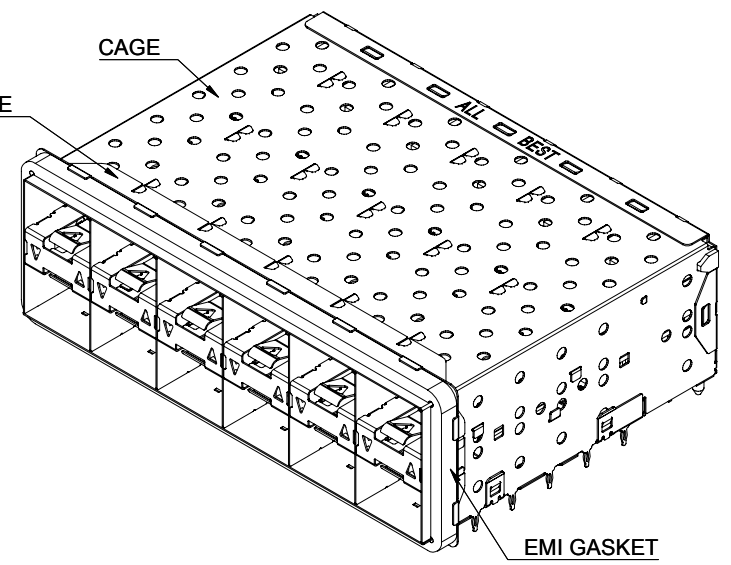

MATERIAL
 CAGE: NICKEL SILVER
 CONNECTOR: LCP 94V-0
 COPPER ALLOY
 EMI GASKET FLANGE: NICKEL SILVER
 EMI GASKET: CONDUCTIVE ELASTOMER,(BLACK)

FINISH
 CONTACT: 15µ" MIN. GOLD ON MATING END;
 30µ" MIN. MATTE TIN ON TERMINATION END;
 ALL UNDERPLATED NICKEL

ELECTRICAL CHARACTERISTICS
 CONTACT CURRENT RATING: 0.5 AMPERE
 VOLTAGE RATING: 30 VAC
 CONTACT RESISTANCE: 80 mΩ MAX.
 DIELECTRIC WITHSTANDING VOLTAGE: 300 VAC

THIS PRINT IS
PRELIMINARY
 UNQUALIFIED PRODUCT
 CONTACT PRODUCT ENGINEERING
 BEFORE USING THIS PRINT



TITLE: Stacked SFP+ 2X6 ASS'Y w/ Internal Thermal Solution & Light Pipe			
DWG#: R-OP-008240-7-F-N2-33		SHEET: 1/3	REV. REF
UNIT: mm	SCALE: A4 6:5	FINISH:	CHECKED:
TOLERANCE: Angle: ± 1° X ± 0.25 .X ± 0.20 .XX ± 0.15		MATERIAL: RoHS Compliant	APPROVED:
THIRD ANGLE PROJECTION		DRAWN: Laura	DATE: 03/22/2024

CROSS HATCHED AREA DENOTES EMI GROUNDING PAD (MUST BE CONNECTED) TO CHASSIS GROUND

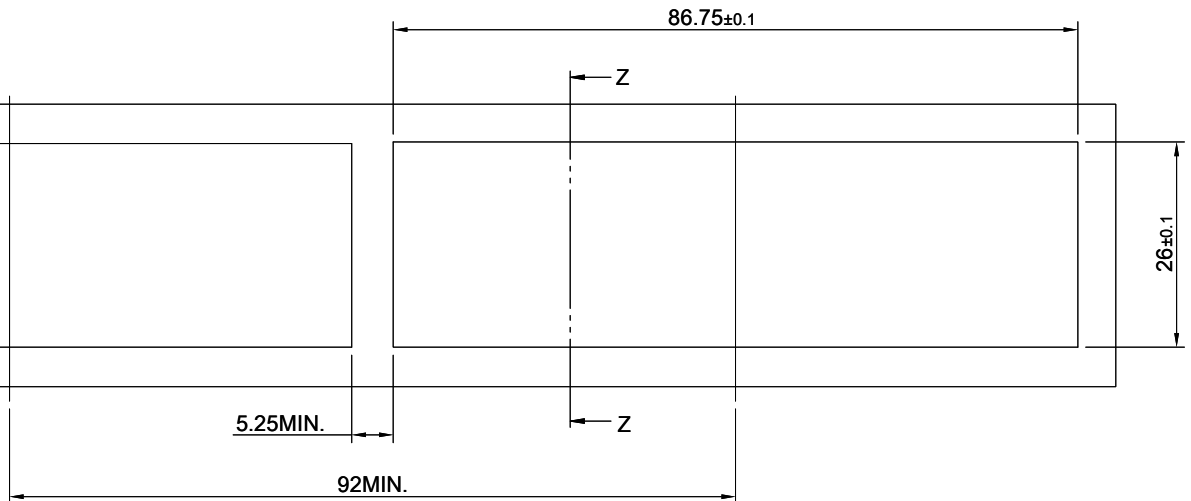
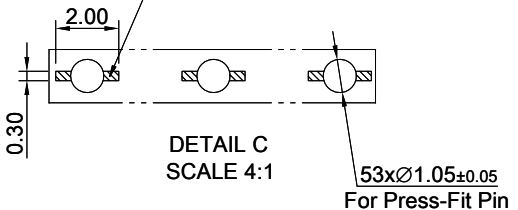

RECOMMENDED BEZEL CUT-OUT SPACING DETAIL
BEZEL THICKNESS 0.8~2.6MM

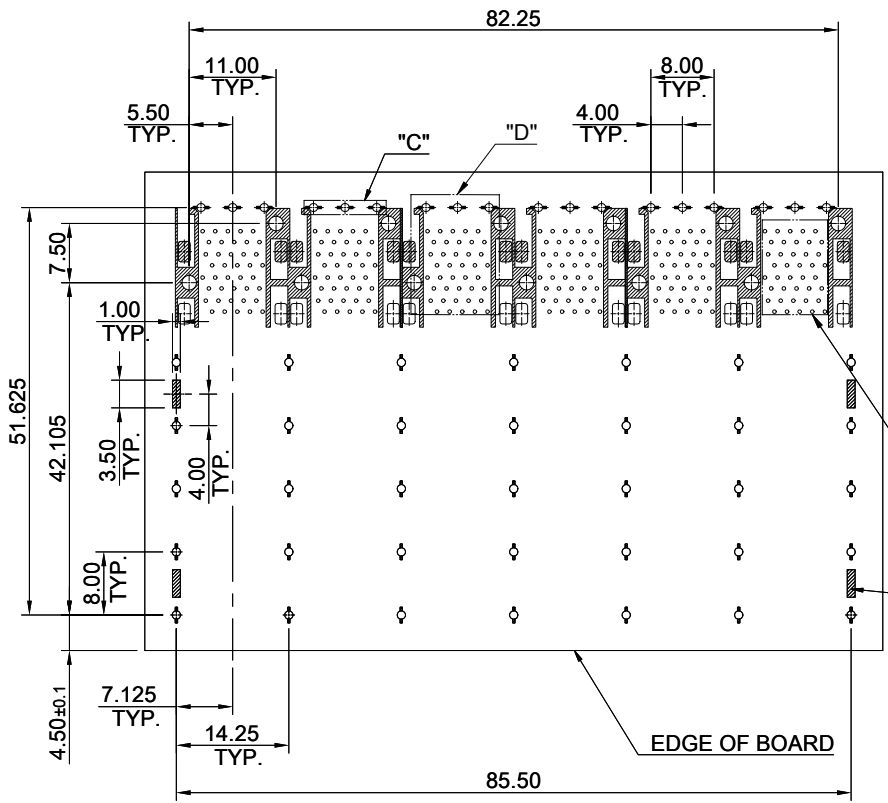

RECOMMENDED PCB LAYOUT
TOLERANCE : ±0.05
MINIMUM PCB THICKNESS OF 1.57MM

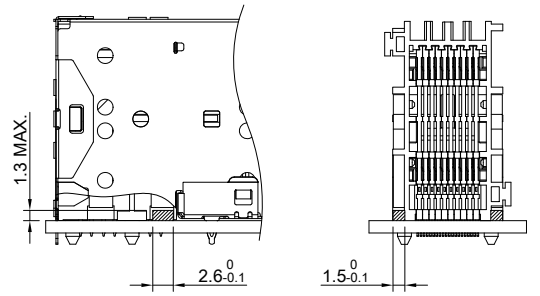
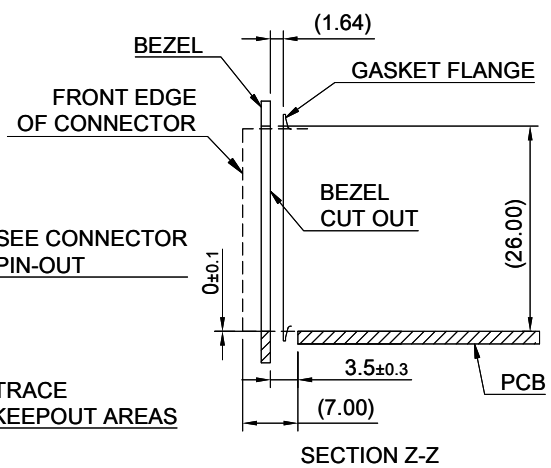

LED CLEARANCE REQUIREMENTS



THIS PRINT IS
PRELIMINARY
UNQUALIFIED PRODUCT
CONTACT PRODUCT ENGINEERING
BEFORE USING THIS PRINT

TITLE: Stacked SFP+ 2X6 ASS'Y w/ Internal Thermal Solution & Light Pipe			SHEET: 2/3	REV. REF
DWG#: R-OP-008240-7-F-N2-33			CHECKED:	APPROVED:
UNIT: mm	SCALE: A4 1:1	FINISH:	DATE: 03/22/2024	
TOLERANCE: Angle: ± 1° X.± 0.15 .X± 0.10 .XX± 0.05		MATERIAL: RoHS Compliant	DRAWN: Laura	

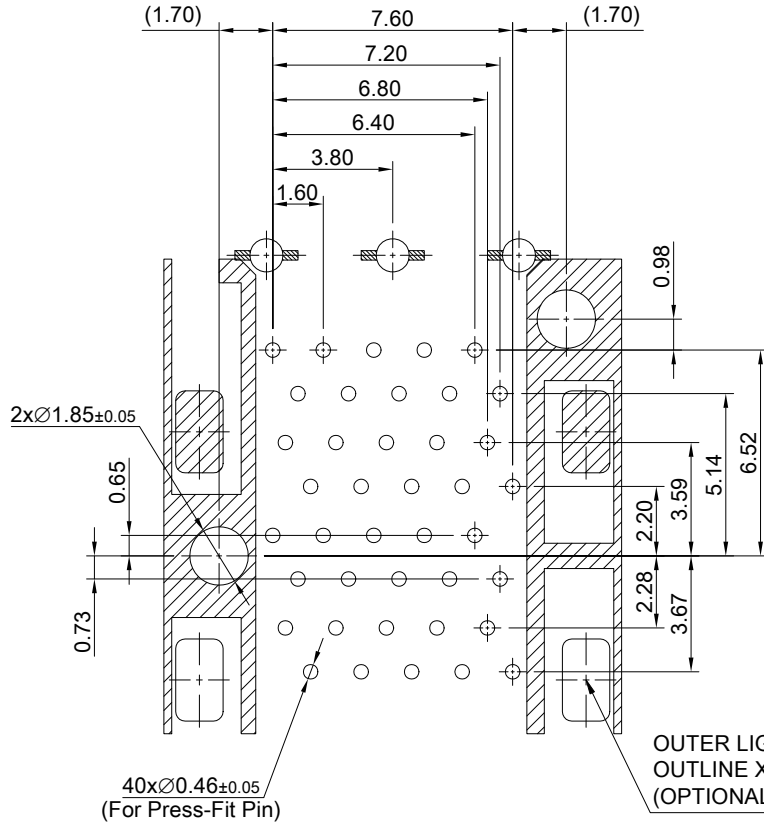

OUTER LIGHTS
OUTLINE X 2PCS
(OPTIONAL LED LAYOUT)

DETAIL D
TOLERANCE: ± 0.05

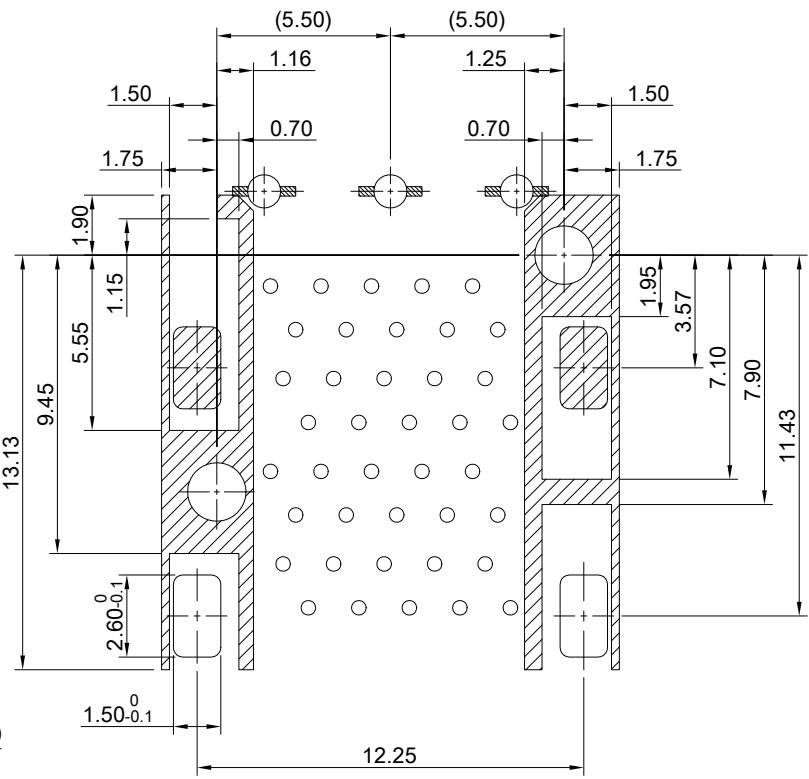

KEEPOUT ZONE DETAIL

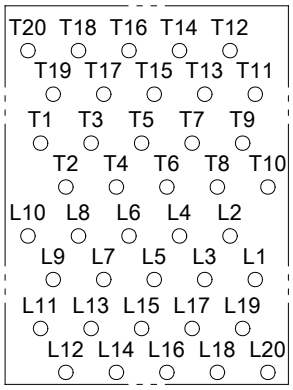
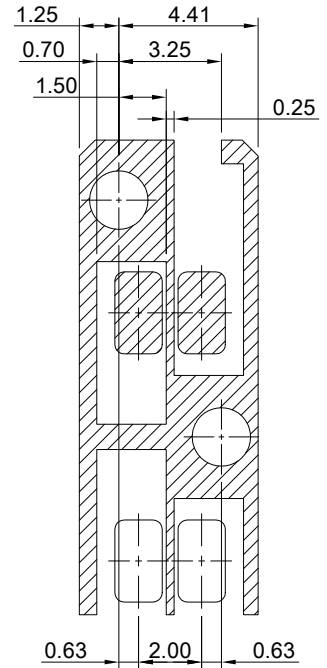

THIS PRINT IS
PRELIMINARY
UNQUALIFIED PRODUCT
CONTACT PRODUCT ENGINEERING
BEFORE USING THIS PRINT



TITLE: Stacked SFP+ 2X6 ASS'Y w/ Internal Thermal Solution & Light Pipe			
DWG#: R-OP-008240-7-F-N2-33		SHEET: 3/3	REV. REF
UNIT: mm	SCALE: A4 4:1	FINISH:	CHECKED:
TOLERANCE: Angle: $\pm 1^\circ$ X. ± 0.15 .X ± 0.10 .XX ± 0.05		MATERIAL: RoHS Compliant	APPROVED:
THIRD ANGLE PROJECTION		DRAWN: Laura	DATE: 03/22/2024