

DETAIL A
SCALE 5:1

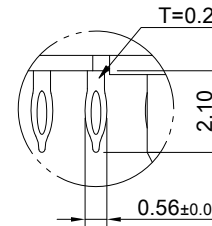

DETAIL B
SCALE 5:1

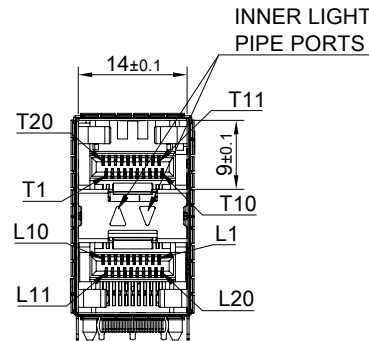
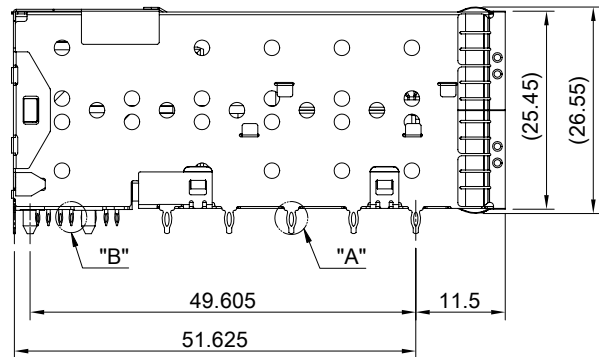
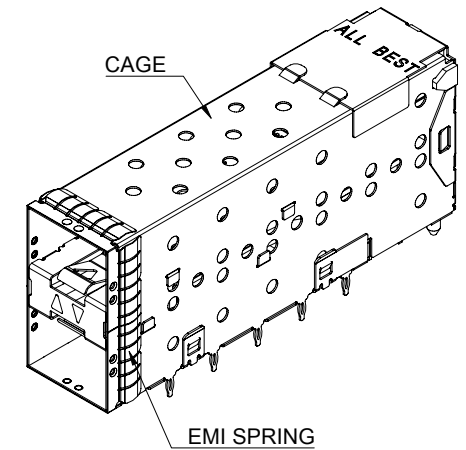

MATERIAL
 CAGE: NICKEL SILVER
 LIGHT PIPE: PC (CLEAR)
 CONNECTOR: LCP 94V-0
 COPPER ALLOY
 EMI SPRING: STAINLESS STEEL

FINISH
 CONTACT: 15µ" MIN. GOLD ON MATING END;
 30µ" MIN. MATTE TIN ON TERMINATION END;
 ALL UNDERPLATED 50µ" MIN. NICKEL

ELECTRICAL CHARACTERISTICS
 CONTACT CURRENT RATING: 0.5 AMPERE
 VOLTAGE RATING: 30 VAC
 CONTACT RESISTANCE: 80 mΩ MAX.
 DIELECTRIC WITHSTANDING VOLTAGE: 300VAC

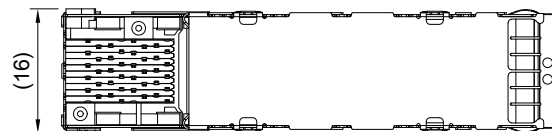

	TITLE: Stacked SFP+ 2X1 Assembly w/ Internal Thermal Solution & Light Pipe			SHEET: 1/3		REV. E	
	DWG#: R-DP-008040-7-F-N2-61			CHECKED: Gary Kang		APPROVED: George Yang	
	UNIT: mm	SCALE: A4 1:1	FINISH:	MATERIAL: RoHS Compliant		DATE: 07/14/2022	
	TOLERANCE: Angle: ± 1° X.± 0.25 .X± 0.20 .XX± 0.15		THIRD ANGLE PROJECTION	DRAWN: Laura			

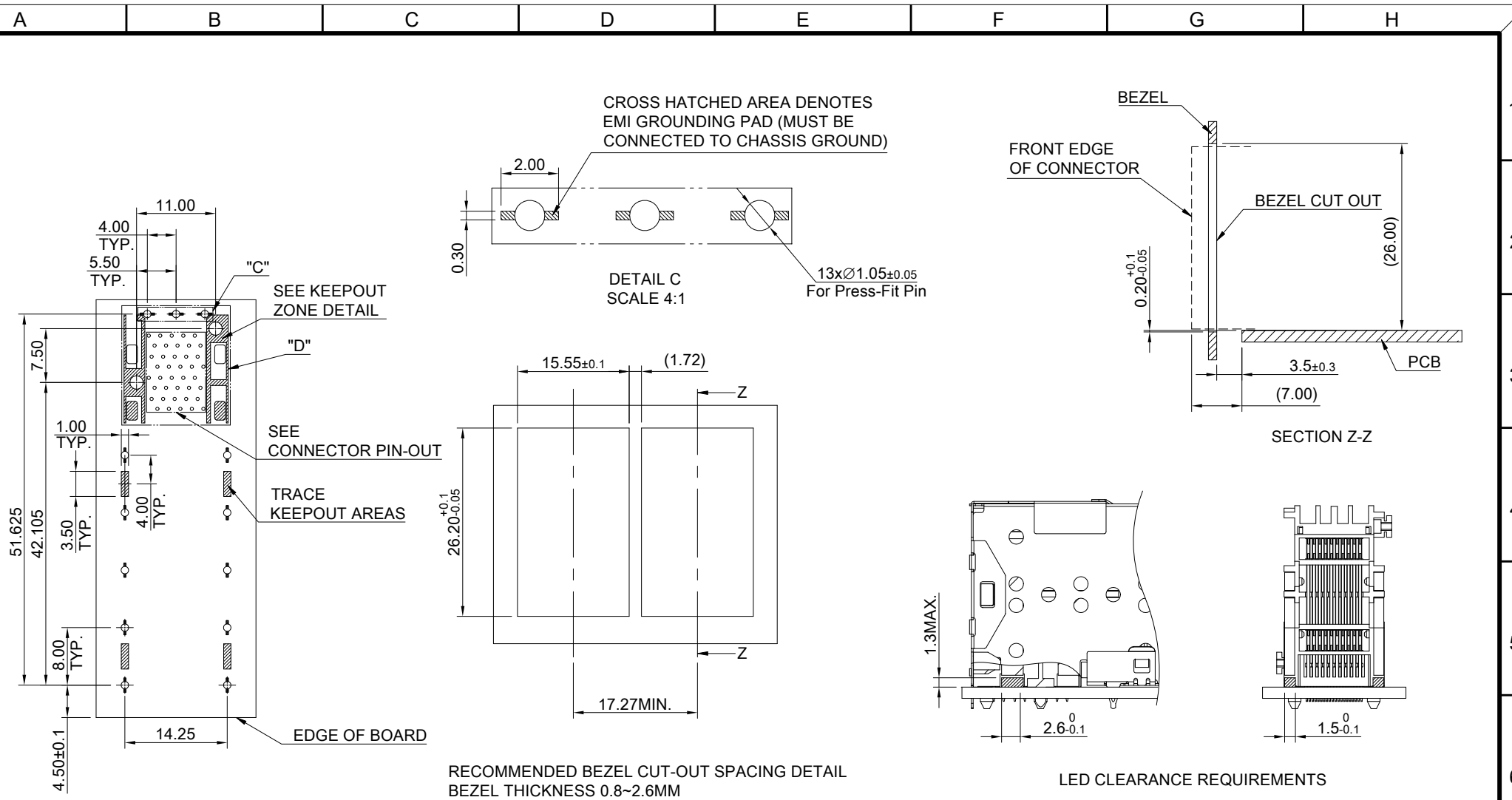

TITLE: Stacked SFP+ 2X1 Assembly w/ Internal Thermal Solution & Light Pipe			
DWG#: R-DP-008040-7-F-N2-61		SHEET: 2/3	REV. E
UNIT: mm	SCALE: A4 5:4	CHECKED: Gary Kang	
THIRD ANGLE PROJECTION		APPROVED: George Yang	
TOLERANCE: Angle: $\pm 1^\circ$ X: ± 0.15 .X: ± 0.10 .XX: ± 0.05		DRAWN: Laura	DATE: 07/14/2022

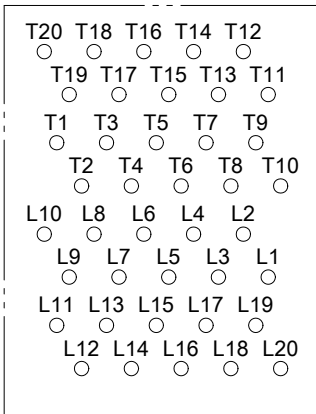
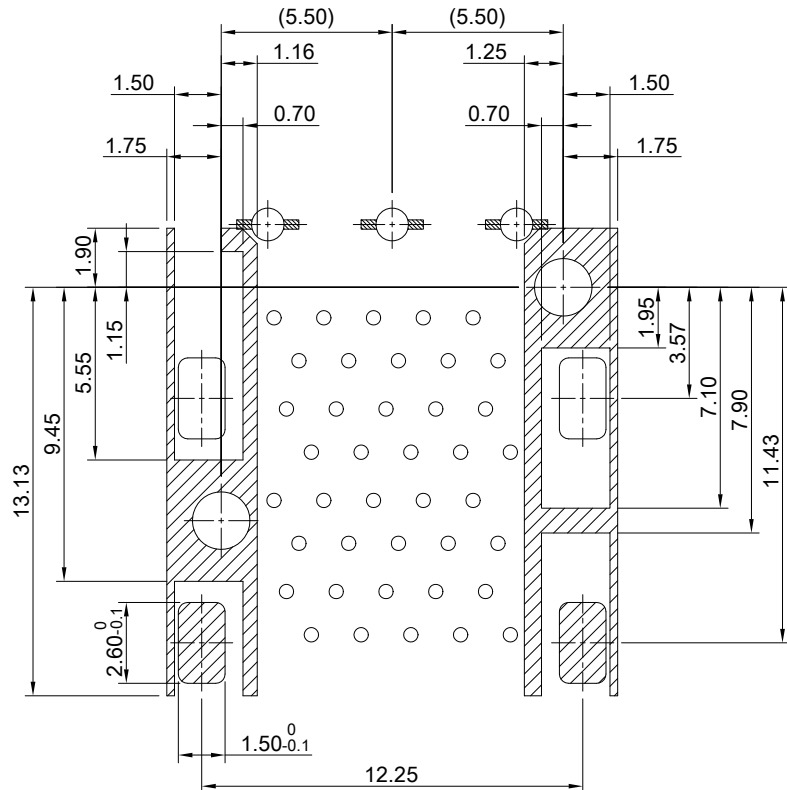
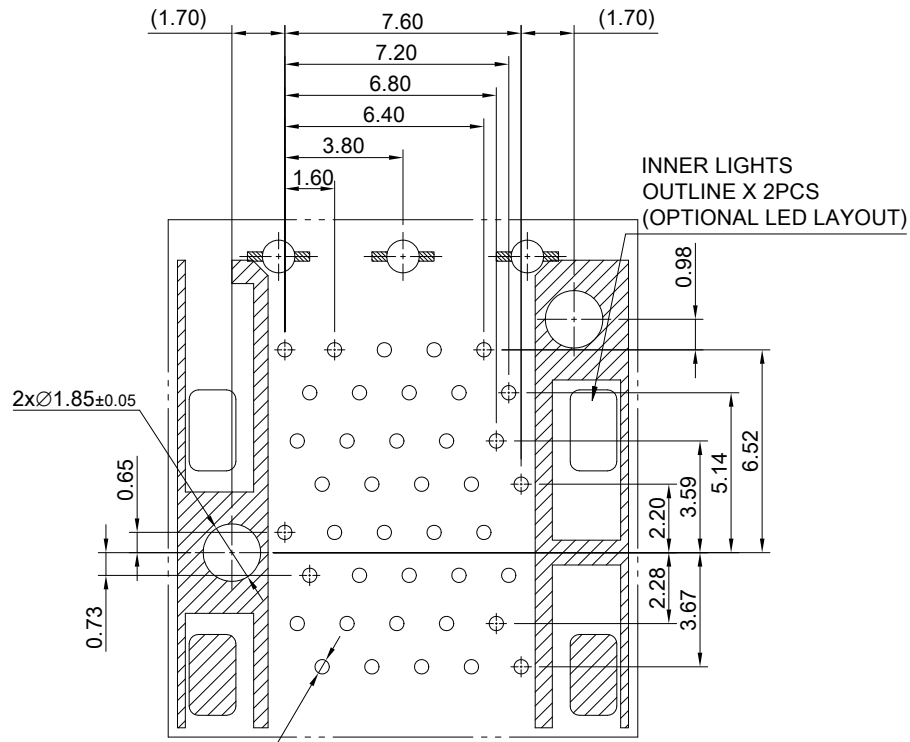

CONNECTOR PIN OUT



TITLE: Stacked SFP+ 2X1 Assembly w/ Internal Thermal Solution & Light Pipe			
DWG#: R-DP-008040-7-F-N2-61		SHEET: 3/3	
UNIT: mm		REV.: E	
SCALE: A4 4:1		CHECKED: Gary Kang	
FINISH:		APPROVED: George Yang	
MATERIAL: RoHS Compliant		DATE: 07/14/2022	
TOLERANCE: Angle: ± 1° X ± 0.15 .X ± 0.10 .XX ± 0.05		DRAWN: Laura	