

DETAIL A
SCALE 5:1

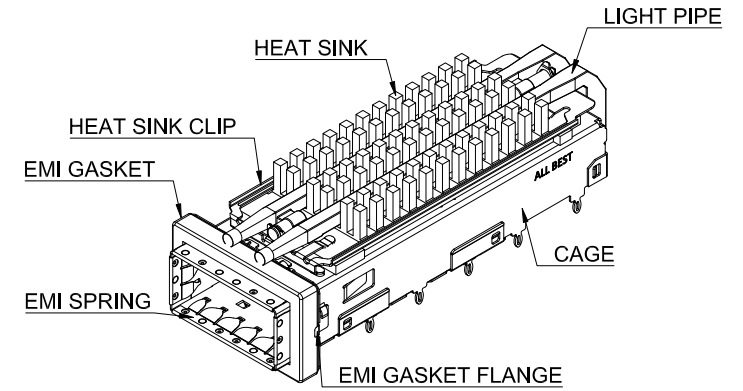
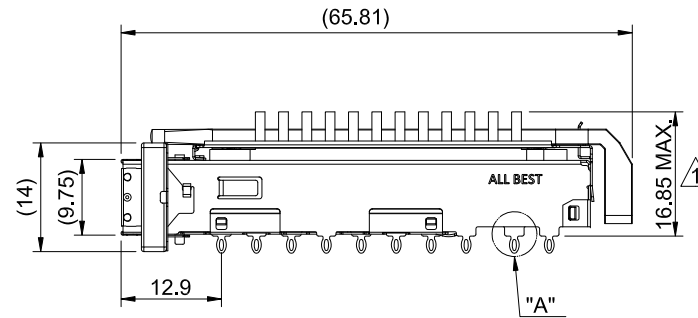

MATERIAL
 CAGE: NICKEL SILVER
 EMI SPRING: STAINLESS STEEL
 EMI GASKET: CONDUCTIVE ELASTOMER
 EMI GASKET FLANGE: STAINLESS STEEL
 HEAT SINK: ALUMINUM
 HEAT SINK CLIP: STAINLESS STEEL
 LIGHT PIPE: PC

FINISH
 HEAT SINK: ANODE PROCESS

NOTE
 ▲ DIMENSION APPLIES WITH MODULE INSERTED IN CAGE



TITLE: QSFP28 1X1 Cage w/ Heat Sink (SAN) & Light Pipe

DWG#: R-OR-ZQ1-4CGEA-MK

SHEET: 1/4
 REV. B

UNIT: mm

SCALE: A4 1:1

FINISH:

CHECKED: Gary Yang

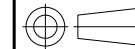

THIRD ANGLE PROJECTION

MATERIAL: RoHS Compliant

APPROVED: George Yang

TOLERANCE: Angle: ± 1°
 X.± 0.25 .X± 0.20 .XX± 0.15

DRAWN: Laura

DATE: 02/12/2019

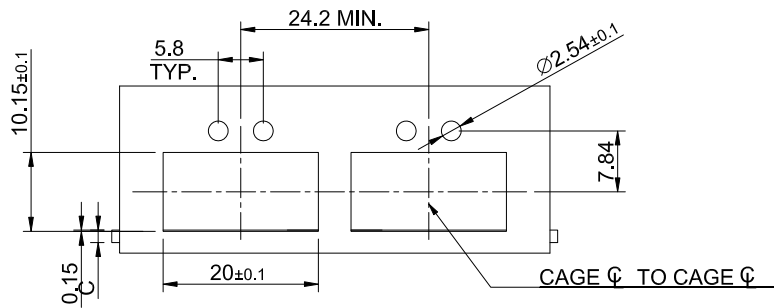

SINGLE-SIDE CONFIGURATION

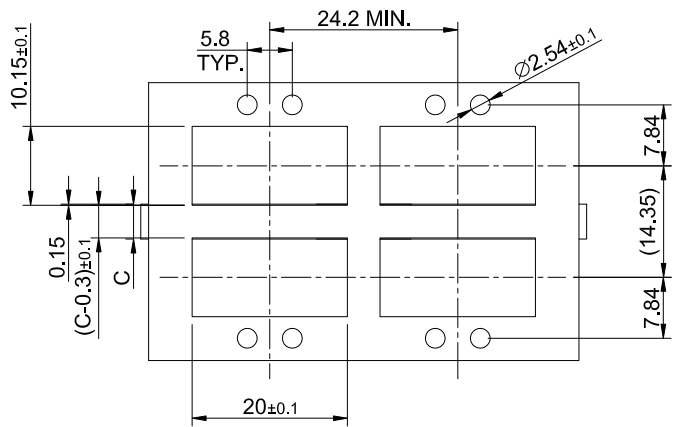
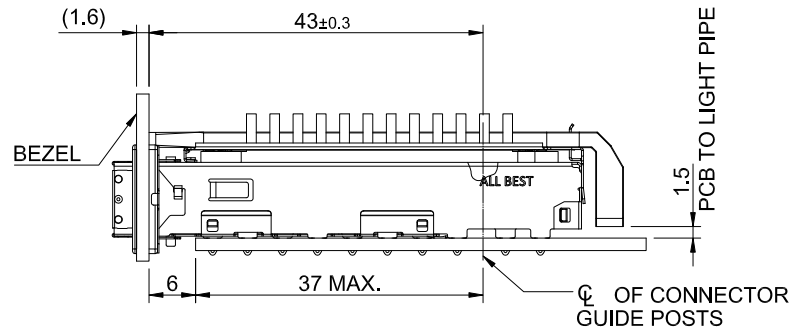

BELLY TO BELLY CONFIGURATION

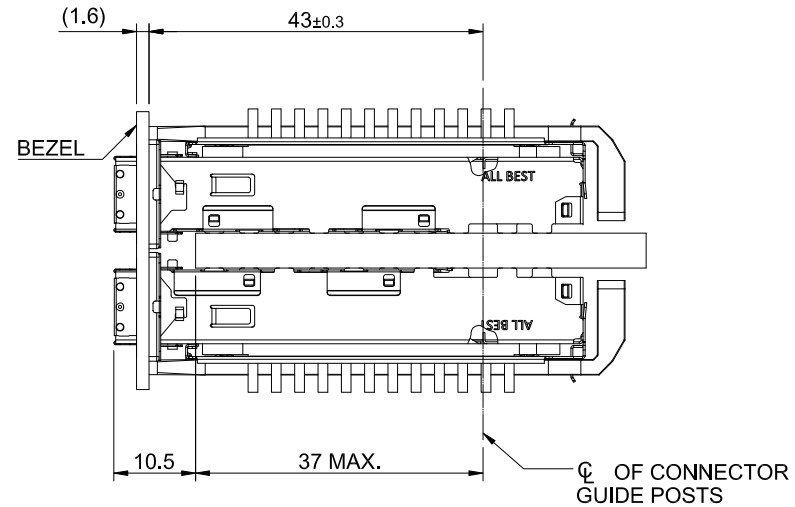

C = THICKNESS OF PC BOARD
 SINGLE-SIDE = 1.6MM (MIN.)
 BELLY TO BELLY = 4.5MM (MIN.)



TITLE: QSFP28 1X1 Cage w/ Heat Sink (SAN) & Light Pipe

DWG#: R-OR-ZQ1-4CGEA-MK

UNIT: mm

SCALE: A4 1:1

FINISH:

SHEET: 2/4
 REV. B

THIRD ANGLE PROJECTION

MATERIAL: RoHS Compliant

CHECKED: Gary Yang

APPROVED: George Yang

TOLERANCE: Angle: ± 1°
 X.± 0.15 .X± 0.10 .XX± 0.05

DRAWN: Laura

DATE: 02/12/2019

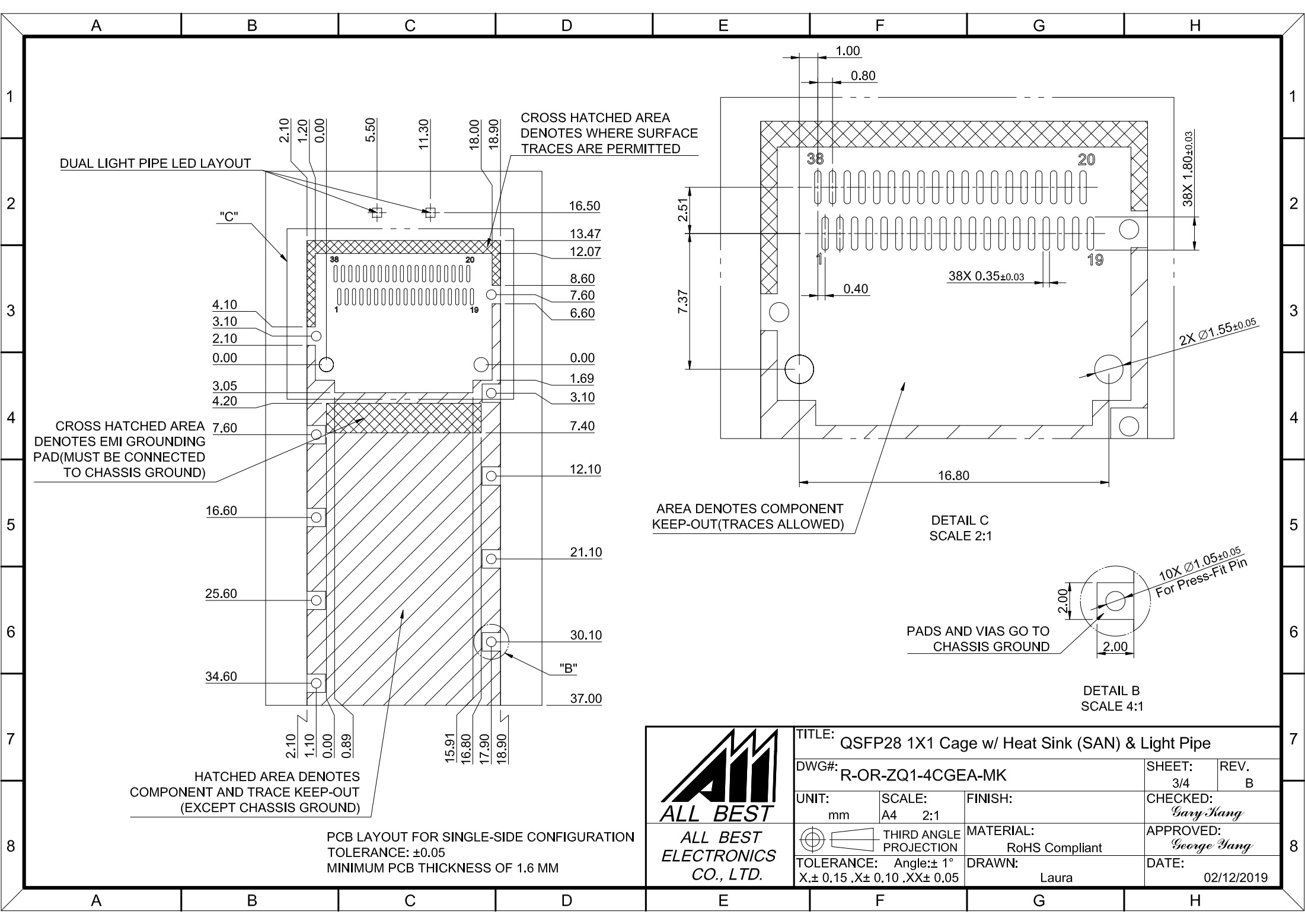

DUAL LIGHT PIPE LED LAYOUT

CROSS HATCHED AREA DENOTES WHERE SURFACE TRACES ARE PERMITTED

CROSS HATCHED AREA DENOTES EMI GROUNDING PAD (MUST BE CONNECTED TO CHASSIS GROUND)

HATCHED AREA DENOTES COMPONENT AND TRACE KEEP-OUT (EXCEPT CHASSIS GROUND)

PCB LAYOUT FOR SINGLE-SIDE CONFIGURATION
TOLERANCE: ±0.05
MINIMUM PCB THICKNESS OF 1.6 MM

AREA DENOTES COMPONENT KEEP-OUT (TRACES ALLOWED)

DETAIL C
SCALE 2:1

PADS AND VIAS GO TO CHASSIS GROUND

DETAIL B
SCALE 4:1



ALL BEST ELECTRONICS CO., LTD.

TITLE: QSFP28 1X1 Cage w/ Heat Sink (SAN) & Light Pipe			
DWG#: R-OR-ZQ1-4CGEA-MK		SHEET: 3/4	REV. B
UNIT: mm	SCALE: A4 2:1	FINISH: RoHS Compliant	CHECKED: Gary Yang
TOLERANCE: X±0.15 .X±0.10 .XX±0.05		MATERIAL: RoHS Compliant	APPROVED: George Yang
THIRD ANGLE PROJECTION		DRAWN: Laura	DATE: 02/12/2019

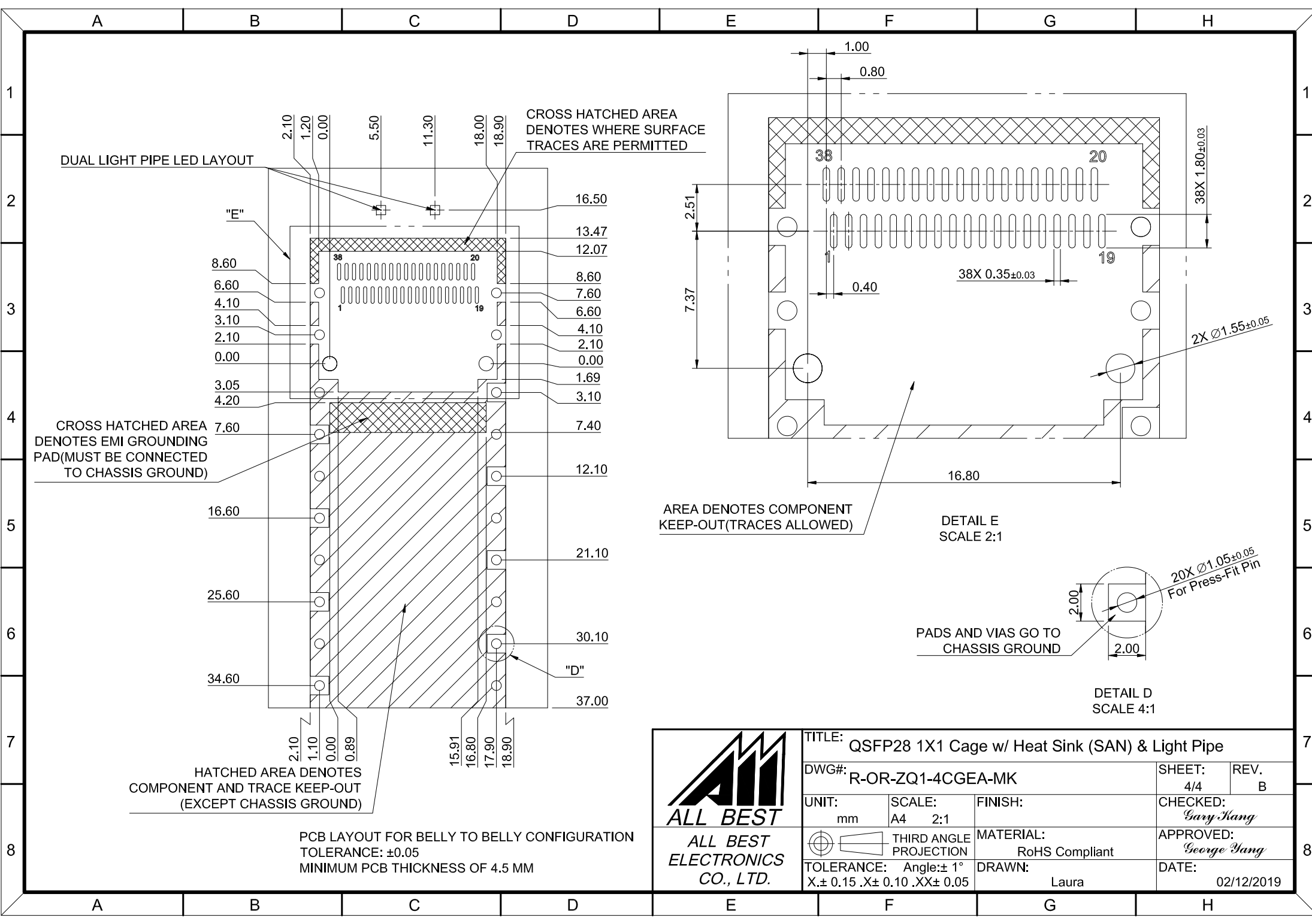

TITLE: QSFP28 1X1 Cage w/ Heat Sink (SAN) & Light Pipe			
DWG#: R-OR-ZQ1-4CGEA-MK		SHEET: 4/4	REV.: B
UNIT: mm	SCALE: A4 2:1	CHECKED: Gary Yang	
THIRD ANGLE PROJECTION		MATERIAL: RoHS Compliant	APPROVED: George Yang
TOLERANCE: Angle: $\pm 1^\circ$ X: ± 0.15 , .X: ± 0.10 , .XX: ± 0.05		DRAWN: Laura	DATE: 02/12/2019