

DETAIL A  
SCALE 4:1

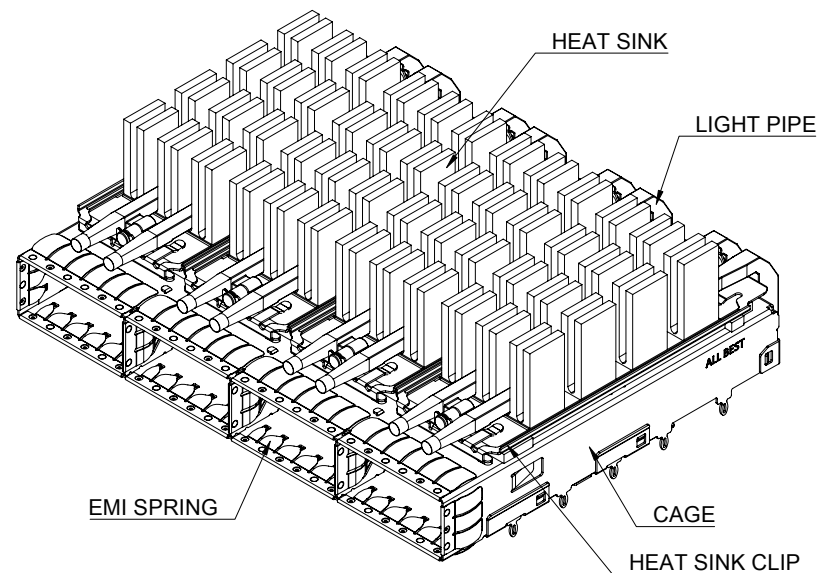

MATERIAL  
 CAGE: NICKEL SILVER  
 HEAT SINK: ALUMINUM  
 HEAT SINK CLIP: STAINLESS STEEL  
 EMI SPRING: STAINLESS STEEL  
 LIGHT PIPE: PC

FINISH  
 HEAT SINK: ANODE PROCESS

NOTE  
 1 DIMENSION APPLIES WITH MODULE INSERTED IN CAGE

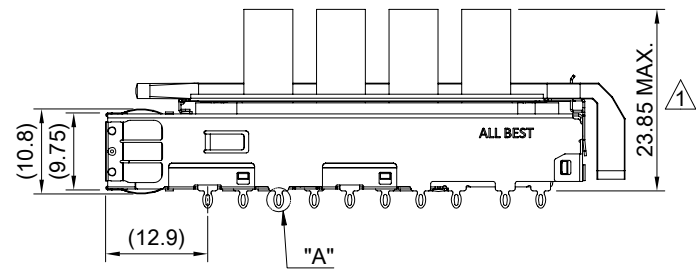

 <b>ALL BEST</b> <b>ELECTRONICS</b> <b>CO., LTD.</b>	TITLE: QSFP28 1X4 Cage Assembly w/ NET Heat Sink & Light Pipe		SHEET: 1/4	REV. B
	DWG#: R-OR-ZQ4-4CMED-MK		CHECKED: Gary Kang	
	UNIT: mm	SCALE: A4 1:1	FINISH:	APPROVED: George Yang
	TOLERANCE: Angle: ± 1° X ± 0.25 .X ± 0.20 .XX ± 0.15		MATERIAL: RoHS Compliant	DATE: 09/27/2021
		DRAWN: Jason Zhao		

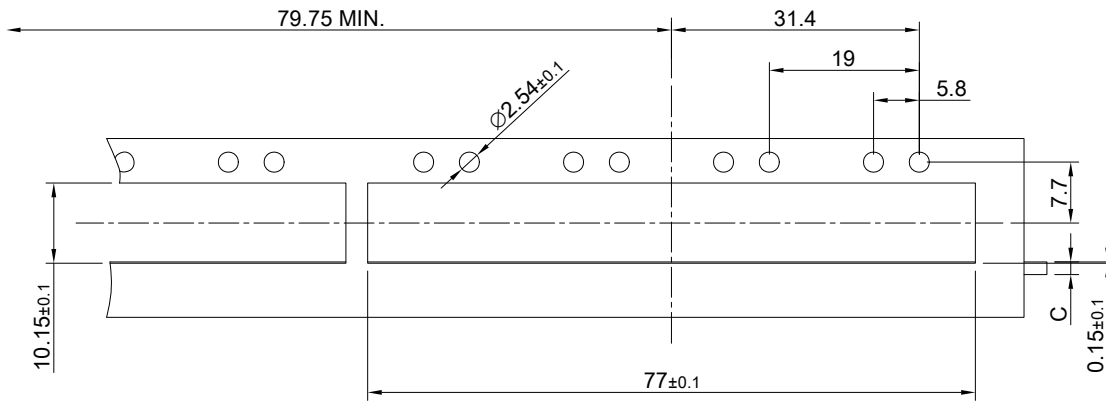

SINGLE-SIDE CONFIGURATION

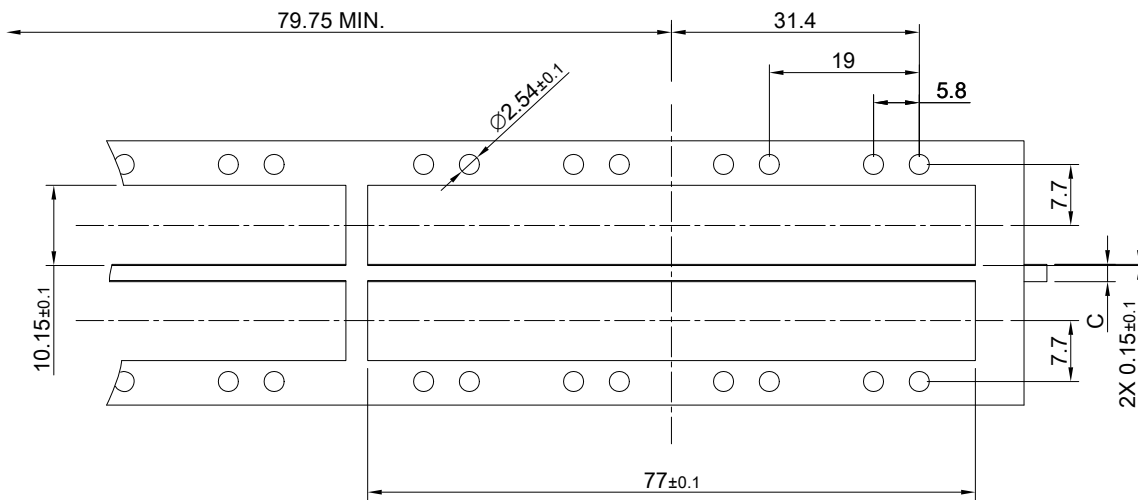
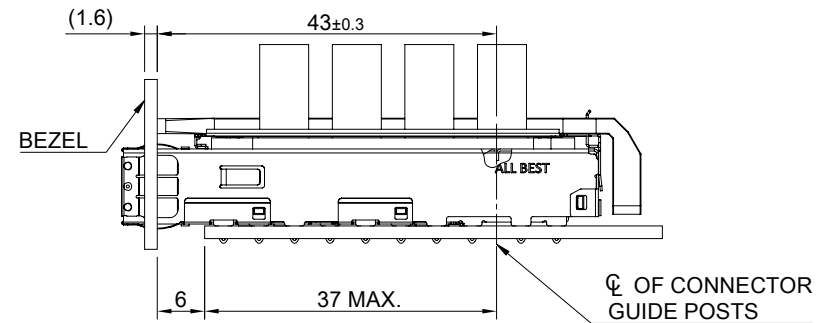

BELLY TO BELLY CONFIGURATION

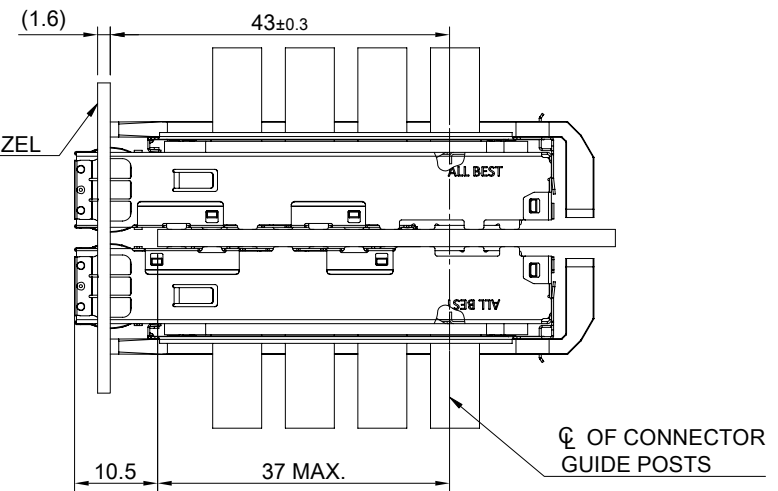



C = THICKNESS OF PC BOARD  
 SINGLE-SIDE = 1.6MM (MIN.)  
 BELLY TO BELLY = 2.2MM (MIN.)

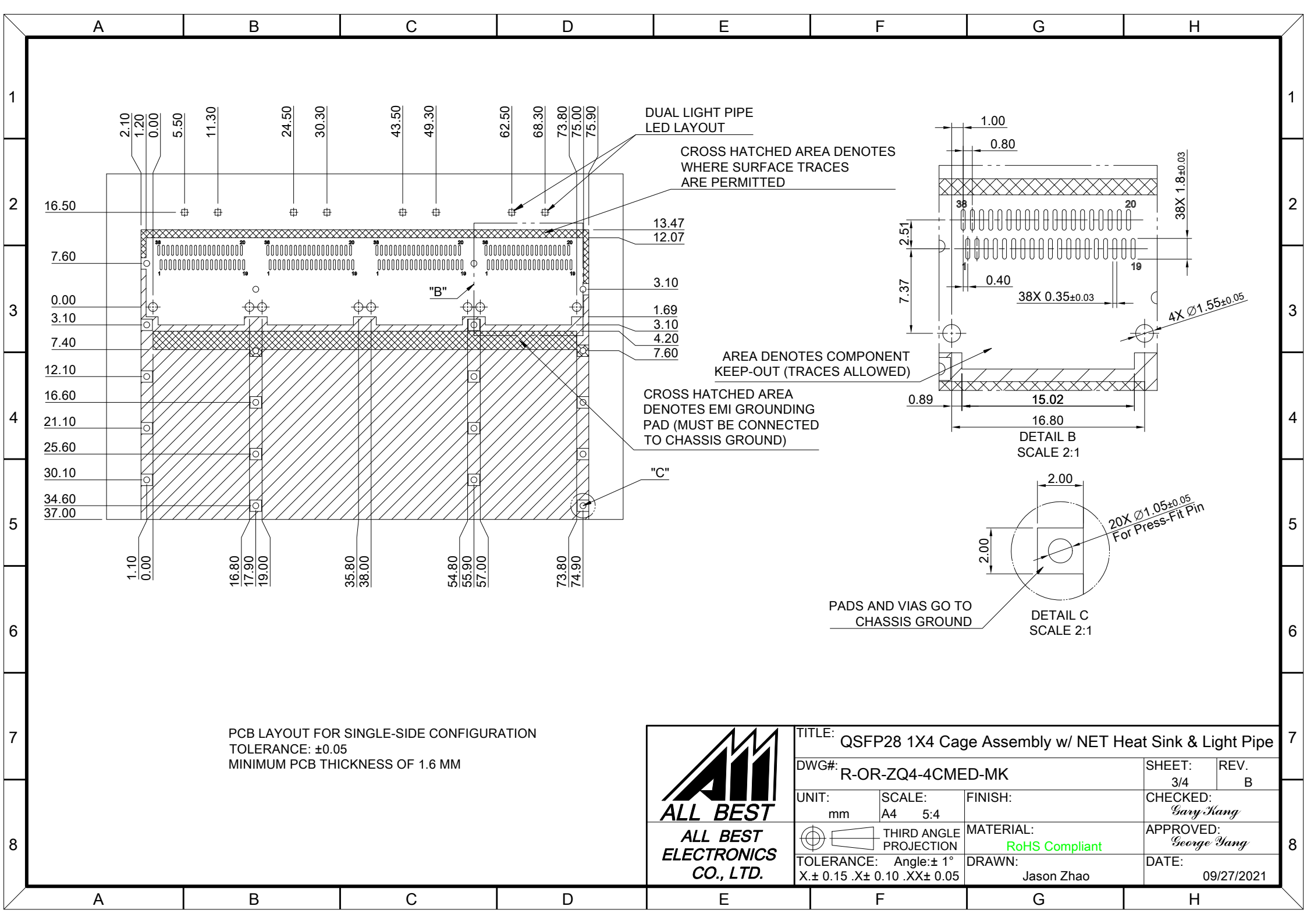

TITLE: QSFP28 1X4 Cage Assembly w/ NET Heat Sink & Light Pipe			
DWG#: R-OR-ZQ4-4CMED-MK		SHEET: 2/4	REV. B
UNIT: mm	SCALE: A4 1:1	CHECKED: Gary Kang	
THIRD ANGLE PROJECTION		APPROVED: George Yang	
TOLERANCE: Angle: ± 1°		DATE: 09/27/2021	
X.± 0.15 .X± 0.10 .XX± 0.05		DRAWN: Jason Zhao	



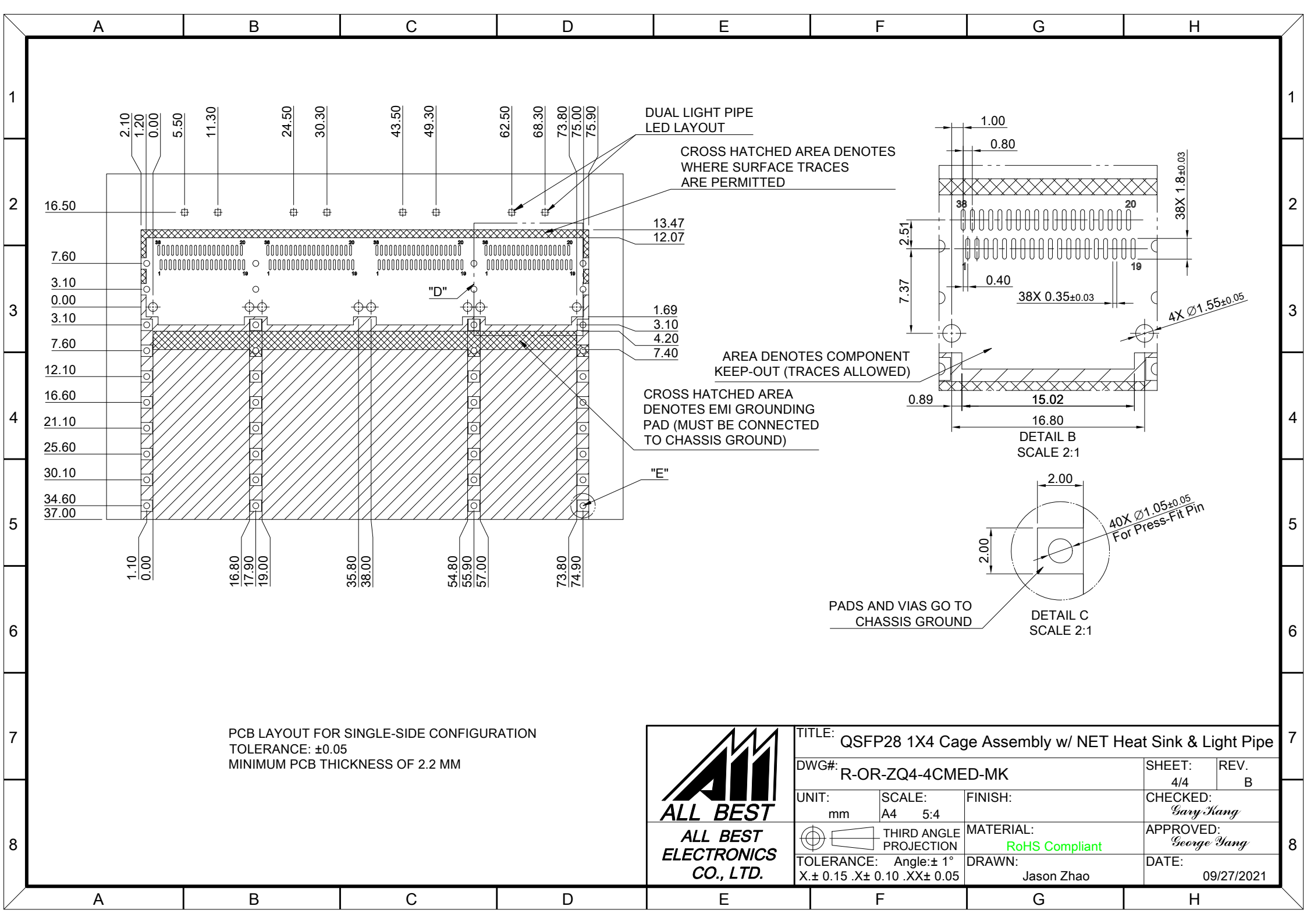

PCB LAYOUT FOR SINGLE-SIDE CONFIGURATION  
 TOLERANCE:  $\pm 0.05$   
 MINIMUM PCB THICKNESS OF 1.6 MM

 <b>ALL BEST</b> <b>ELECTRONICS</b> <b>CO., LTD.</b>		TITLE: QSFP28 1X4 Cage Assembly w/ NET Heat Sink & Light Pipe	
		DWG#: R-OR-ZQ4-4CMED-MK	
UNIT: mm	SCALE: A4 5:4	FINISH:	SHEET: 3/4
 THIRD ANGLE PROJECTION		MATERIAL: <b>RoHS Compliant</b>	REV. B
TOLERANCE: Angle: $\pm 1^\circ$ X: $\pm 0.15$ .X: $\pm 0.10$ .XX: $\pm 0.05$		DRAWN: Jason Zhao	CHECKED: <i>Gary Kang</i>
		DATE: 09/27/2021	APPROVED: <i>George Yang</i>



PCB LAYOUT FOR SINGLE-SIDE CONFIGURATION  
 TOLERANCE: ±0.05  
 MINIMUM PCB THICKNESS OF 2.2 MM

 <b>ALL BEST ELECTRONICS CO., LTD.</b>		TITLE: QSFP28 1X4 Cage Assembly w/ NET Heat Sink & Light Pipe	
		DWG#: R-OR-ZQ4-4CMED-MK	
UNIT: mm	SCALE: A4 5:4	FINISH:	SHEET: 4/4
 THIRD ANGLE PROJECTION		MATERIAL: <b>RoHS Compliant</b>	REV: B
TOLERANCE: Angle: ± 1° X. ± 0.15 .X ± 0.10 .XX ± 0.05		DRAWN: Jason Zhao	CHECKED: <i>Gary Kang</i>
		DATE: 09/27/2021	APPROVED: <i>George Yang</i>