

A B C D E F G H

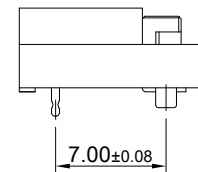
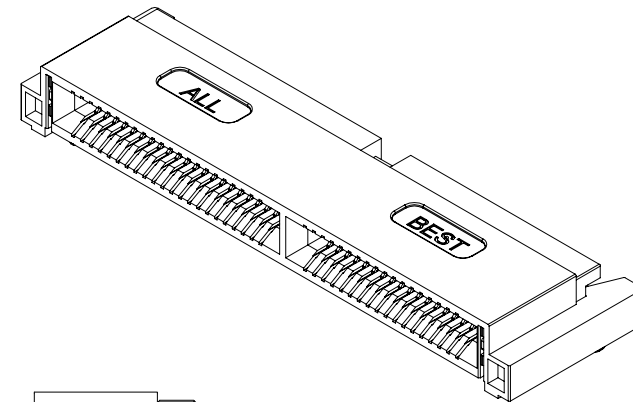
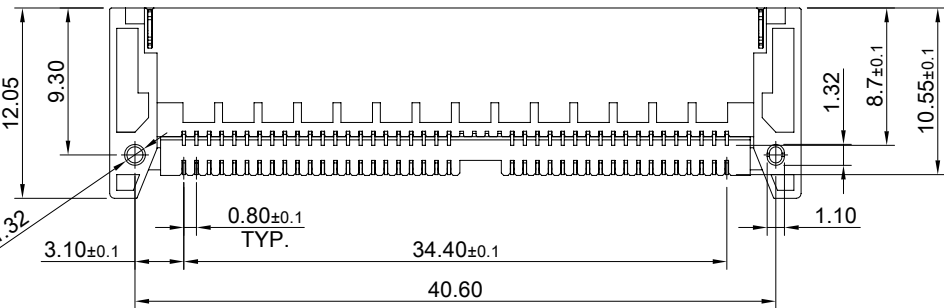
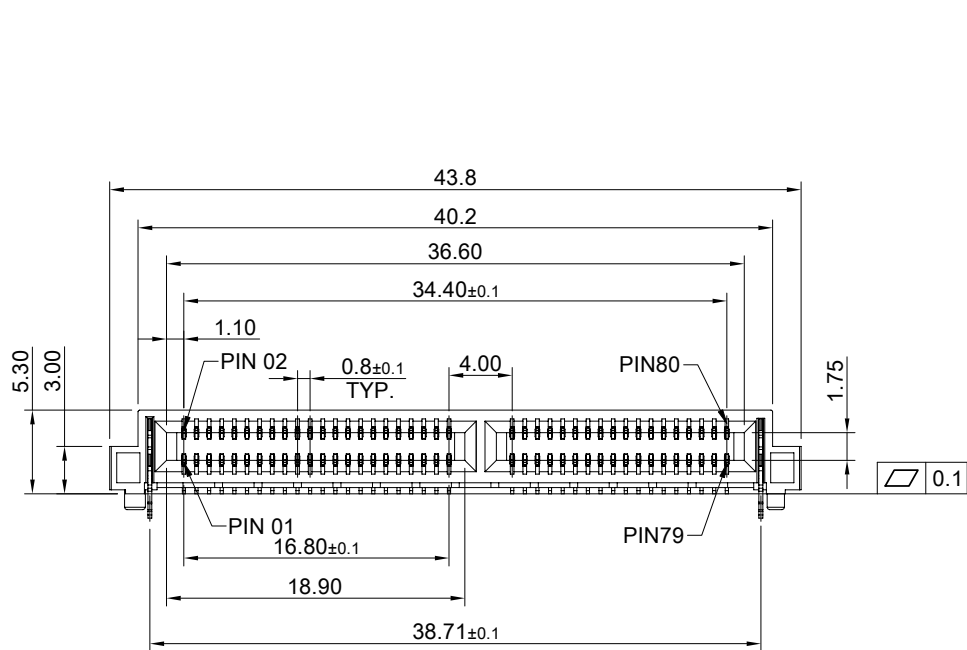

MATERIAL
 CONTACTS: COPPER ALLOY
 INSULATOR: LCP THERMOPLASTIC 94V-0

CONTACTS: 5μ" MIN. GOLD ON MATING END;
 100μ" MIN. MATTE TIN ON SOLDER FOOT AREA
 ALL UNDERPLATED NICKEL

ELECTRICAL CHARACTERISTICS
 CONTACT CURRENT RATING: 2.8 AMPERE(2 Pins)
 VOLTAGE RATING: 240VAC
 MAX CYCLES: 100

ENVIRONMENT
 OPERATION TEMPERATURE: -55°C TO 125°C
 SMT TEMPERATURE: 260°C



TITLE: 0.8mm 80Pin High Speed Assembly			
DWG#: R-HF-08080-9AXX		SHEET: 1/2	REV. A
UNIT: mm	SCALE: A4 2:1	FINISH:	CHECKED: Gary Kang
THIRD ANGLE PROJECTION		MATERIAL: RoHS Compliant	APPROVED: George Yang
TOLERANCE: Angle: ± 1° X ± 0.20 .X ± 0.15 .XX ± 0.10		DRAWN: Yilu	DATE: 05/27/2022

A B C D E F G H

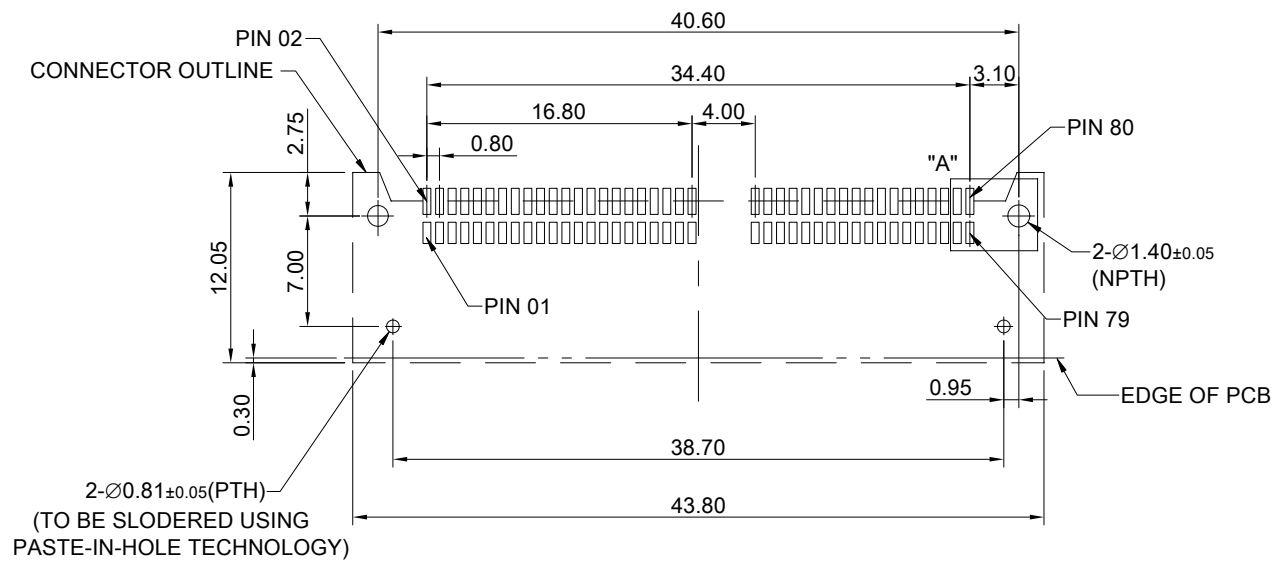

RECOMMENDED PCB LAYOUT
TOLERANCE: ±0.05

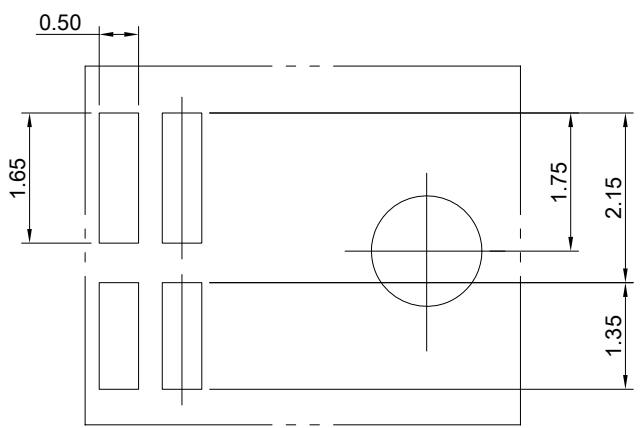

DETAIL A
SCALE 5:1

2-Ø0.81±0.05(PTH)
(TO BE SLODERED USING
PASTE-IN-HOLE TECHNOLOGY)

 ALL BEST ELECTRONICS CO., LTD.	TITLE: 0.8mm 80Pin High Speed Assembly			SHEET: 2/2	REV. A
	DWG#: R-HF-08080-9AXX			CHECKED: Gary Kang	
	UNIT: mm	SCALE: A4 2:1	FINISH:	APPROVED: George Yang	
	TOLERANCE: Angle: ± 1° X: ± 0.15 .X: ± 0.10 .XX: ± 0.05		MATERIAL: RoHS Compliant	DATE: 05/27/2022	
		THIRD ANGLE PROJECTION	DRAWN: Yilu		