

DETAIL A
SCALE 4:1

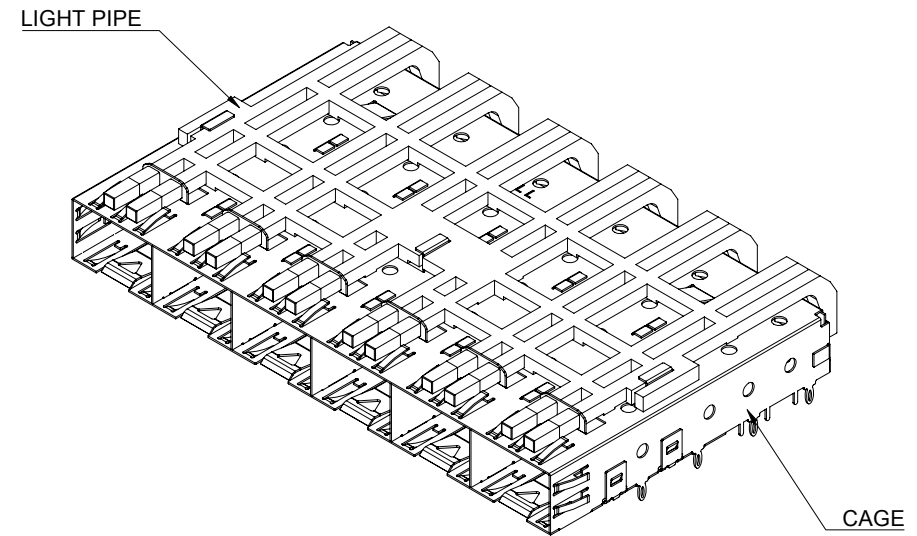

MATERIAL
CAGE: NICKEL SILVER
LIGHT PIPE: PC

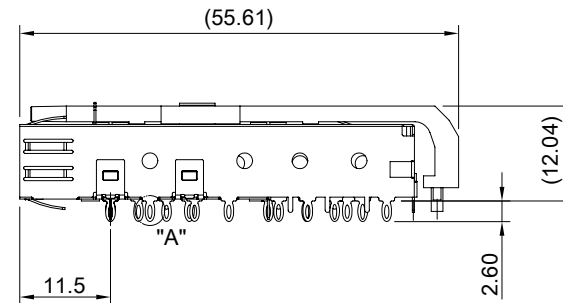

TITLE: SFP 1X6 Cage Assembly w/ Light Pipe				
DWG#: R-SH-008120-7-F			SHEET: 1/2	REV. A
UNIT: mm	SCALE: A4 1:1	FINISH:	CHECKED: Gary Kang	
TOLERANCE: Angle: ± 1° X ± 0.25 .X ± 0.20 .XX ± 0.15		MATERIAL: RoHS Compliant	APPROVED: George Yang	
DRAWN: Ting			DATE: 03/28/2023	

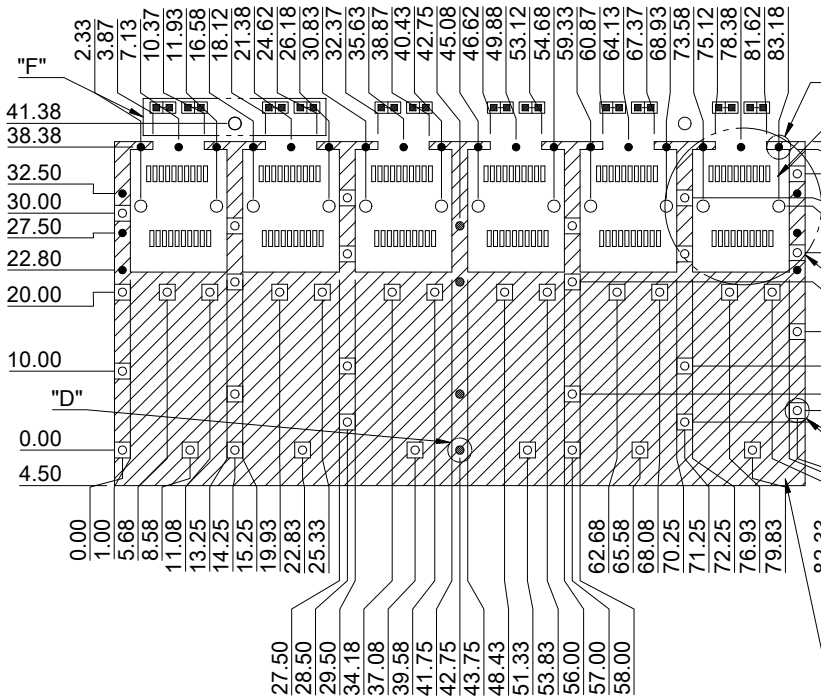

THIS AREA DENOTES COMPONENT KEEP-OUT (TRACES ALLOWED)

HATCHED AREA DENOTES COMPONENTS AND TRACE KEEP-OUT (EXCEPT CHASSIS GROUND)

RECOMMENDED PCB LAYOUT TOLERANCE: ±0.05

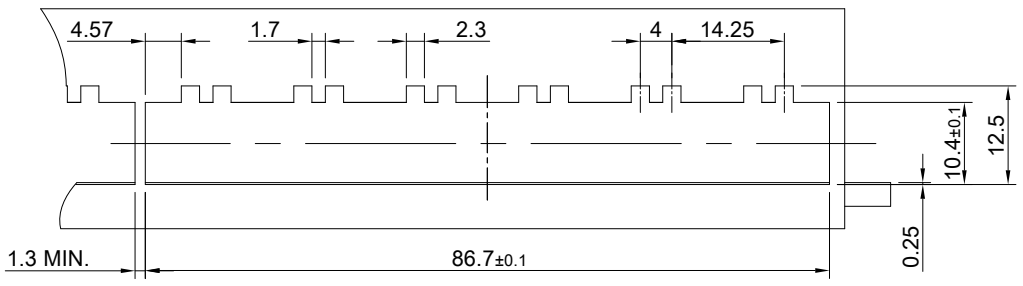

RECOMMENDED BEZEL CUT-OUT

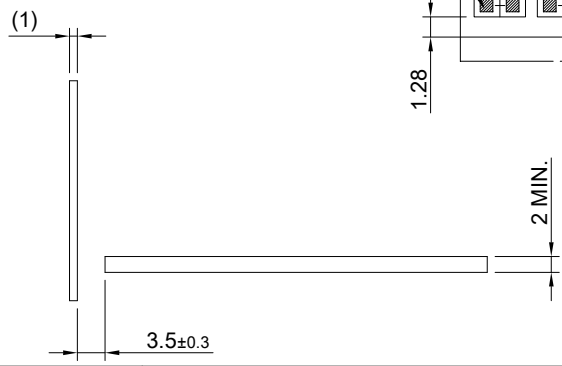
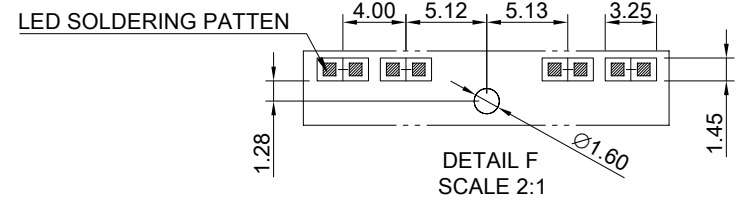
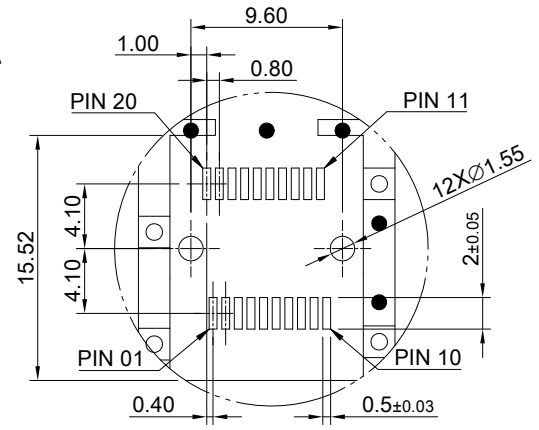
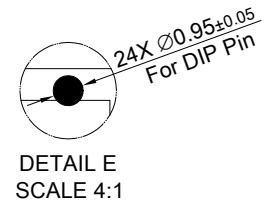
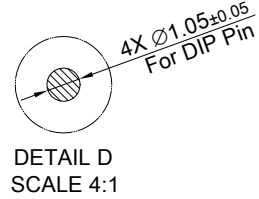
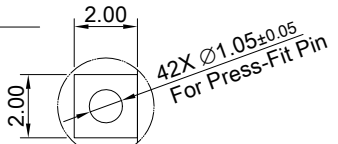

<p>ALL BEST ELECTRONICS CO., LTD.</p>	TITLE: SFP 1X6 Cage Assembly w/ Light Pipe		SHEET: 2/2	REV. A
	DWG#: R-SH-008120-7-F		CHECKED: Gary Kang	APPROVED: George Yang
	UNIT: mm	SCALE: A4 1:1	FINISH:	MATERIAL: RoHS Compliant
	TOLERANCE: Angle: ± 1° X ± 0.15 .X ± 0.10 .XX ± 0.05		DRAWN: Ting	DATE: 03/28/2023