

DETAIL A
SCALE 5:1

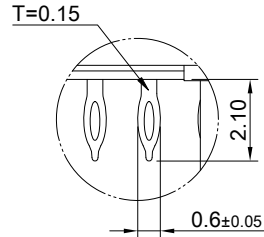

DETAIL B
SCALE 5:1

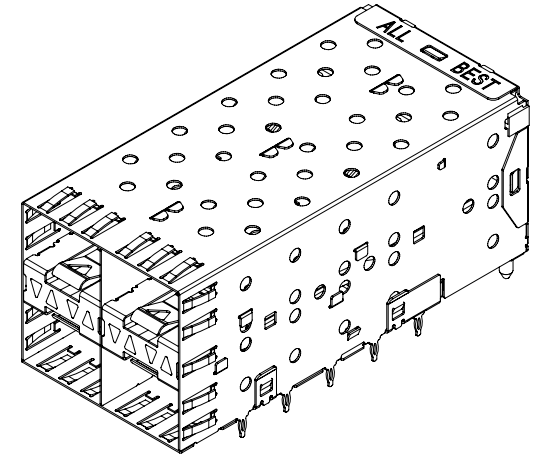
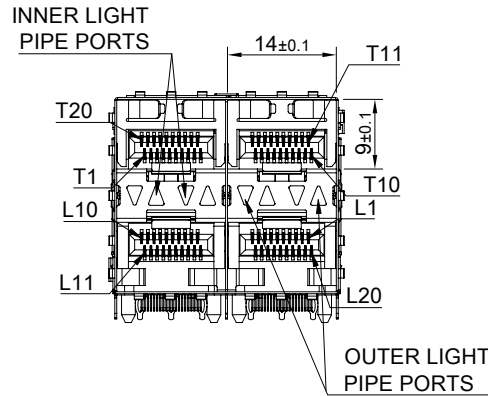

MATERIAL
 CAGE: NICKEL SILVER
 CONNECTOR: PA9T 94V-0 (BLACK)
 LCP 94V-0 (DARK GRAY)
 COPPER ALLOY
 LIGHT PIPE: PC (CLEAR)

FINISH
 CONTACT: 15µ" MIN. GOLD ON MATING END;
 30µ" MIN. MATTE TIN ON TERMINATION END;
 ALL UNDERPLATED 50µ" MIN. NICKEL

ELECTRICAL CHARACTERISTICS
 CONTACT CURRENT RATING: 0.5 AMPERE
 VOLTAGE RATING: 30 VAC
 CONTACT RESISTANCE: 80 mΩ MAX.
 DIELECTRIC WITHSTANDING VOLTAGE: 300VAC



TITLE: Transformed SFP 2X2 w/ Light Pipe			
DWG#: R-OP-008080-7-F-N-18		SHEET: 1/3	REV. C
UNIT: mm	SCALE: A4 1:1	CHECKED: Gary Yang	
THIRD ANGLE PROJECTION		APPROVED: George Yang	
TOLERANCE: Angle: ± 1° X.± 0.25 .XX± 0.15		MATERIAL: RoHS Compliant	DATE: 06/09/2021
		DRAWN: Laura	

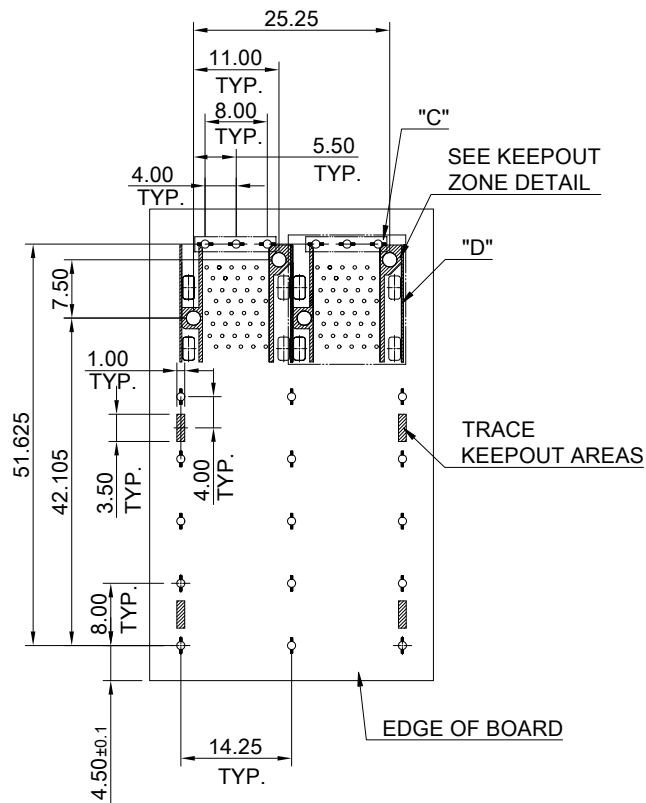

RECOMMENDED PCB LAYOUT
TOLERANCE : ±0.05
MINIMUM PCB THICKNESS OF 1.57MM

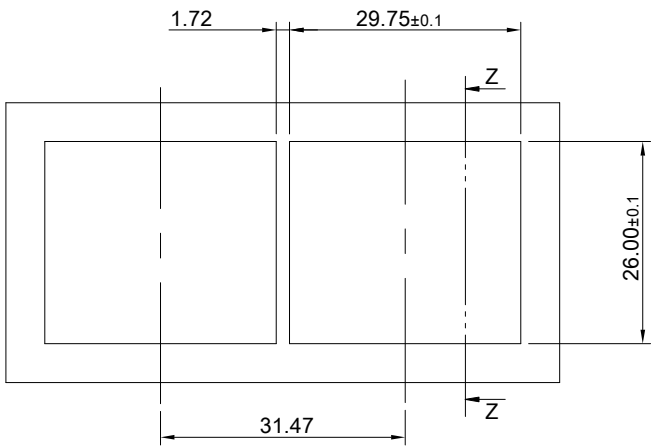

RECOMMENDED BEZEL CUT-OUT SPACING DETAIL
BEZEL THICKNESS 0.8~2.6MM

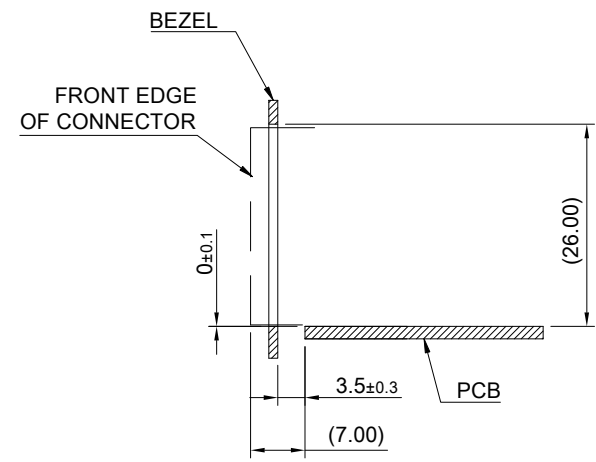

SECTION Z-Z

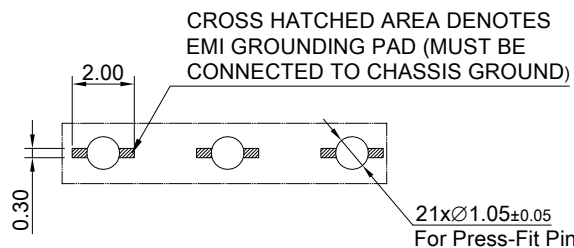

DETAIL C
SCALE 4:1

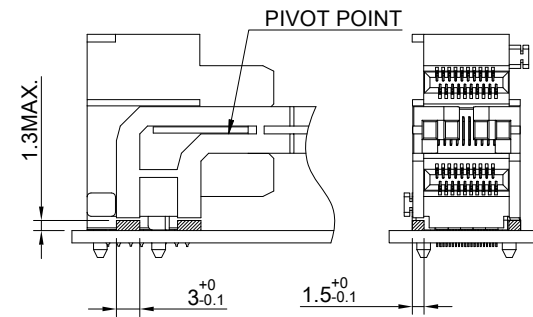

LED CLEARANCE REQUIREMENTS



TITLE: Transformed SFP 2X2 w/ Light Pipe			
DWG#: R-OP-008080-7-F-N-18		SHEET: 2/3	REV. C
UNIT: mm	SCALE: A4 1:1	CHECKED: Gary Heng	
THIRD ANGLE PROJECTION		MATERIAL: RoHS Compliant	APPROVED: George Yang
TOLERANCE: Angle: ± 1° X.± 0.15 .X± 0.10 .XX± 0.05		DRAWN: Laura	DATE: 06/09/2021

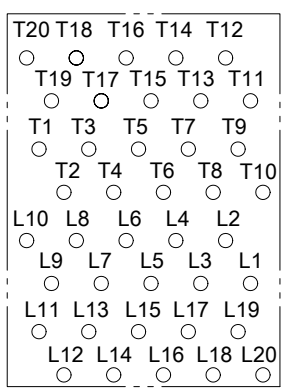
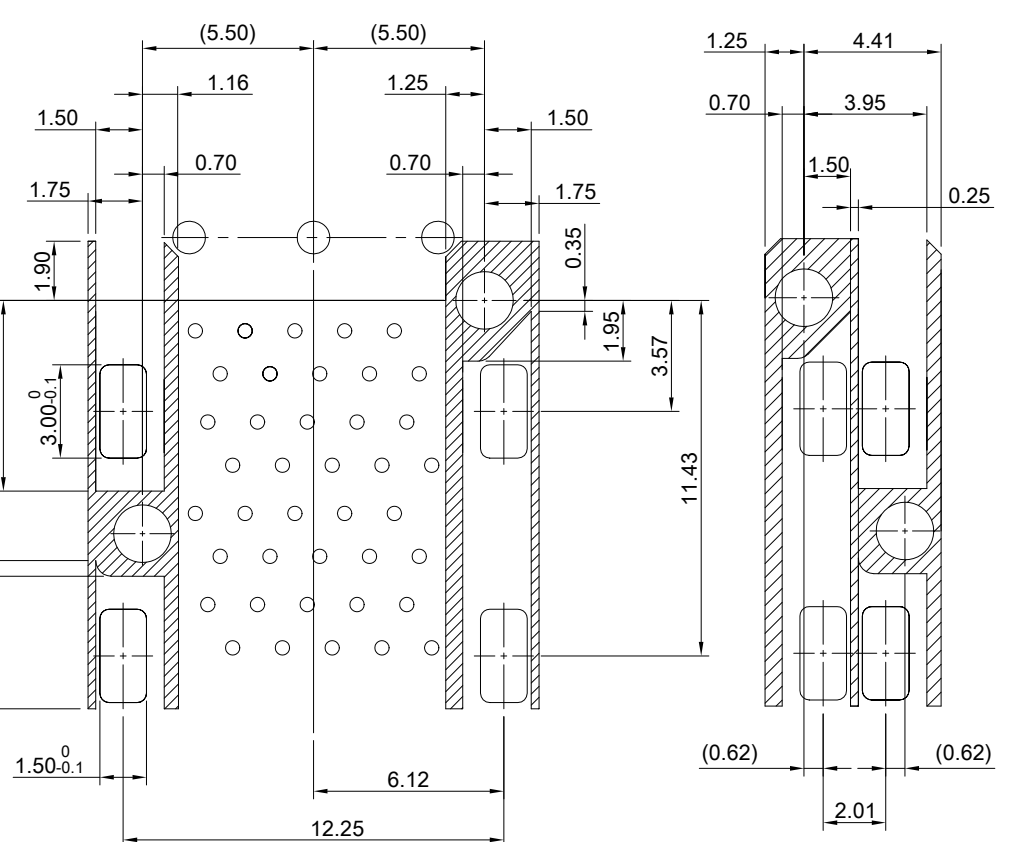
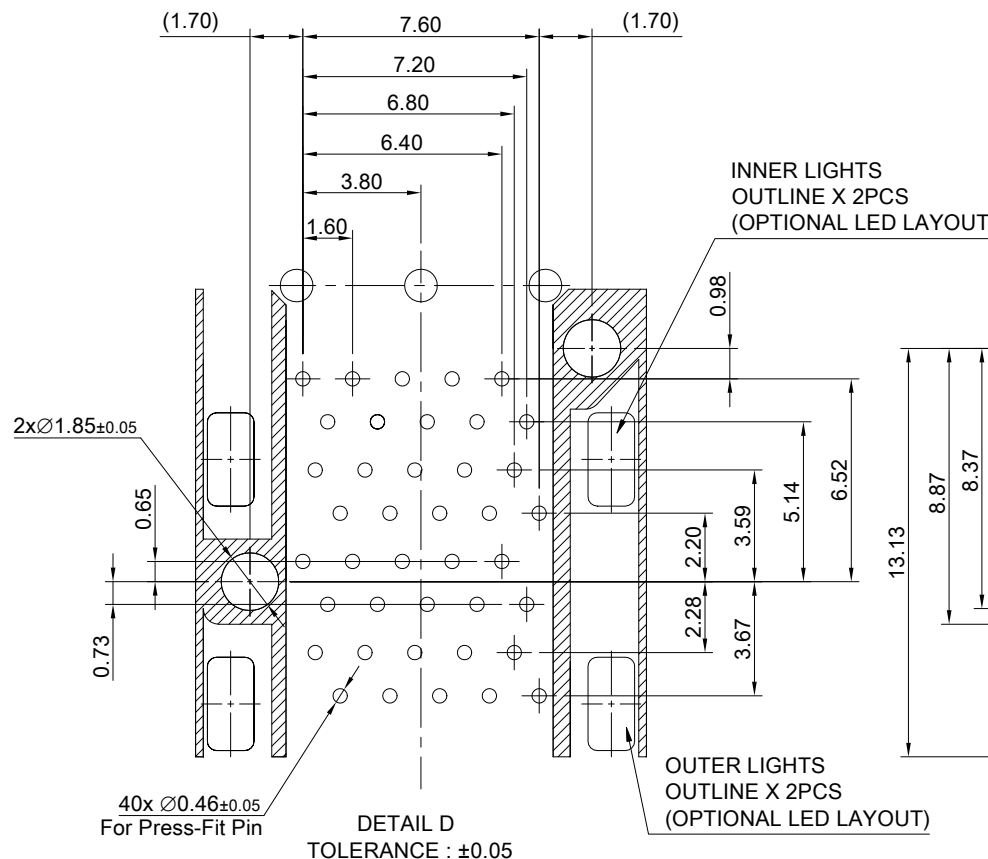
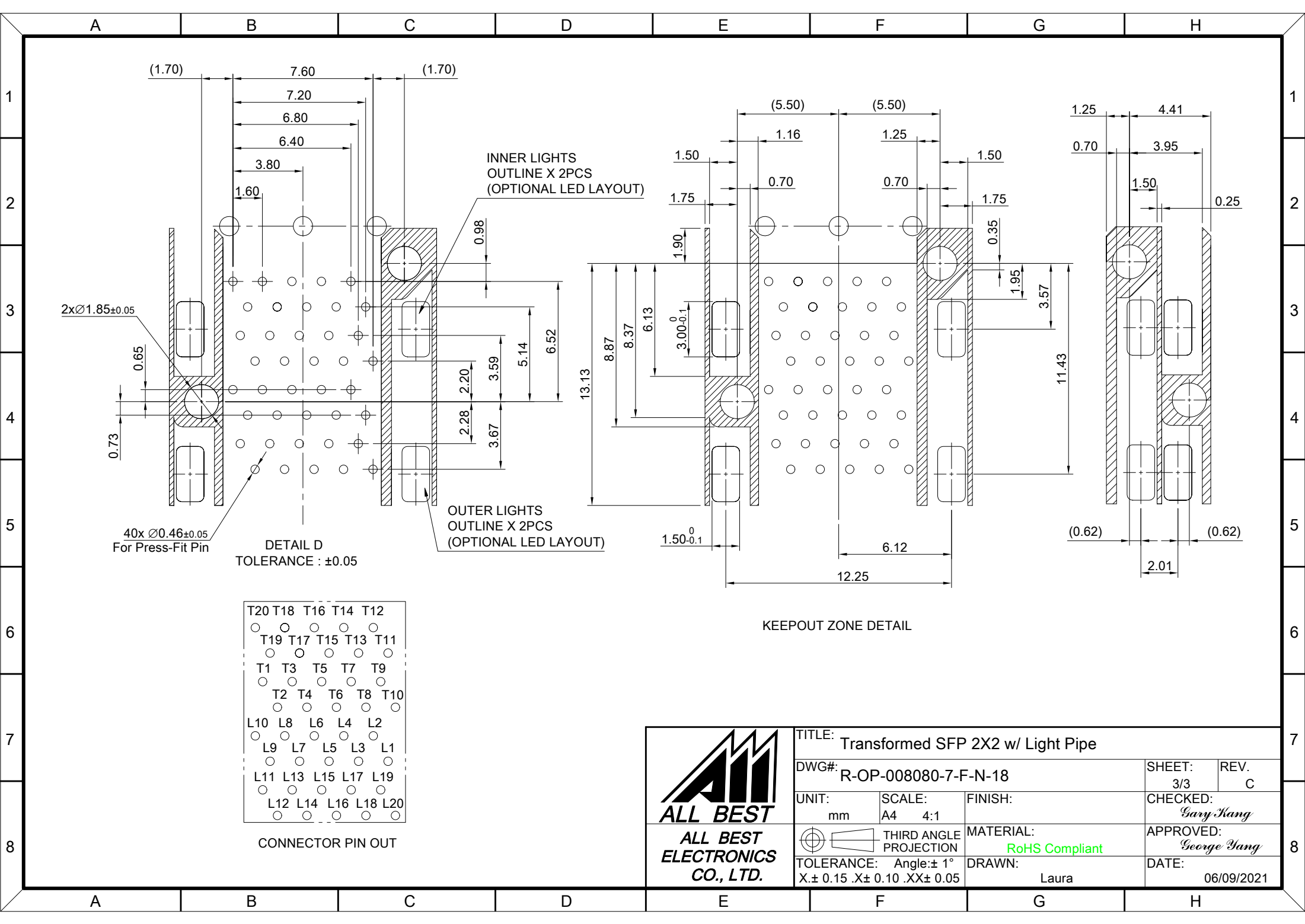

CONNECTOR PIN OUT



TITLE: Transformed SFP 2X2 w/ Light Pipe			
DWG#: R-OP-008080-7-F-N-18		SHEET: 3/3	REV. C
UNIT: mm	SCALE: A4 4:1	FINISH:	CHECKED: Gary Yang
THIRD ANGLE PROJECTION		MATERIAL: RoHS Compliant	APPROVED: George Yang
TOLERANCE: Angle: $\pm 1^\circ$ X: ± 0.15 .X: ± 0.10 .XX: ± 0.05		DRAWN: Laura	DATE: 06/09/2021