

DETAIL A
SCALE 5:1

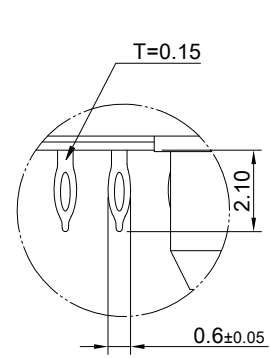

DETAIL B
SCALE 5:1

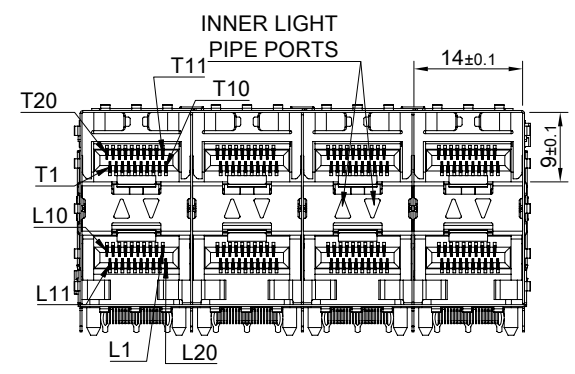
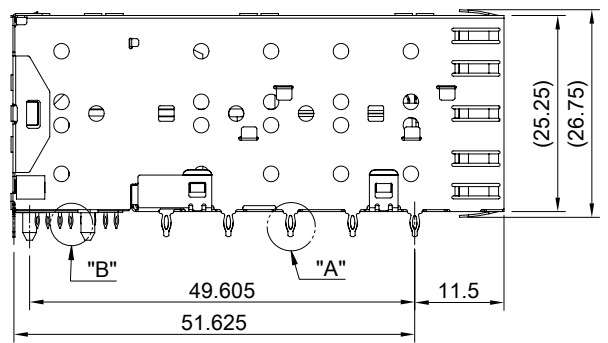
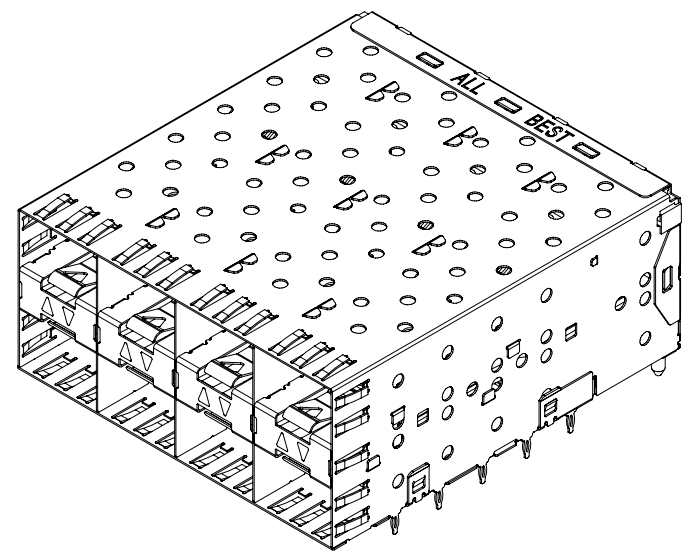

MATERIAL
 CAGE: NICKEL SILVER
 CONNECTOR: PA9T 94V-0 (BLACK)
 LCP 94V-0 (DARK GRAY)
 COPPER ALLOY
 LIGHT PIPE: PC (CLEAR)

FINISH
 CONTACT: 15µ" MIN. GOLD ON MATING END;
 30µ" MIN. TIN ON TERMINATION END;
 ALL UNDERPLATED 50µ" MIN. NICKEL

ELECTRICAL CHARACTERISTICS
 CONTACT CURRENT RATING: 0.5 AMPERE
 VOLTAGE RATING: 30 VAC
 CONTACT RESISTANCE: 80 mΩ MAX.
 DIELECTRIC WITHSTANDING VOLTAGE: 300VAC

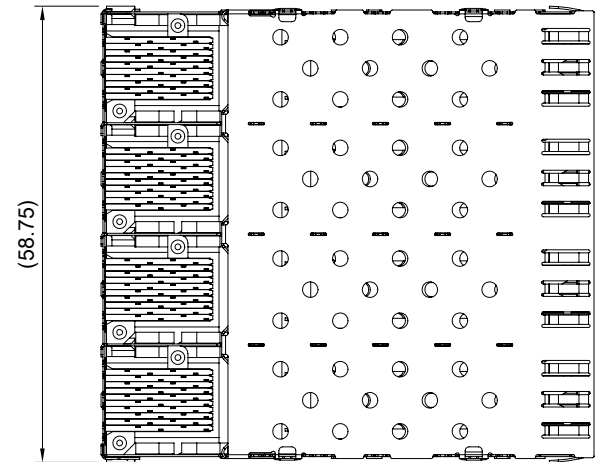

| | | | | | |
|--|---|---------------|--------------------------|-----------------------|--|
| | TITLE: Transformed SFP 2X4 w/ Light Pipe | | SHEET: 1/3 | REV. C | |
| | DWG#: R-OP-008160-7-F-N-20 | | CHECKED: Gary Kang | | |
| | UNIT: mm | SCALE: A4 1:1 | FINISH: RoHS Compliant | APPROVED: George Yang | |
| | TOLERANCE: Angle: ± 1° X ± 0.25 .X ± 0.20 .XX ± 0.15 | | MATERIAL: RoHS Compliant | DATE: 04/20/2022 | |
| | | DRAWN: Laura | | | |

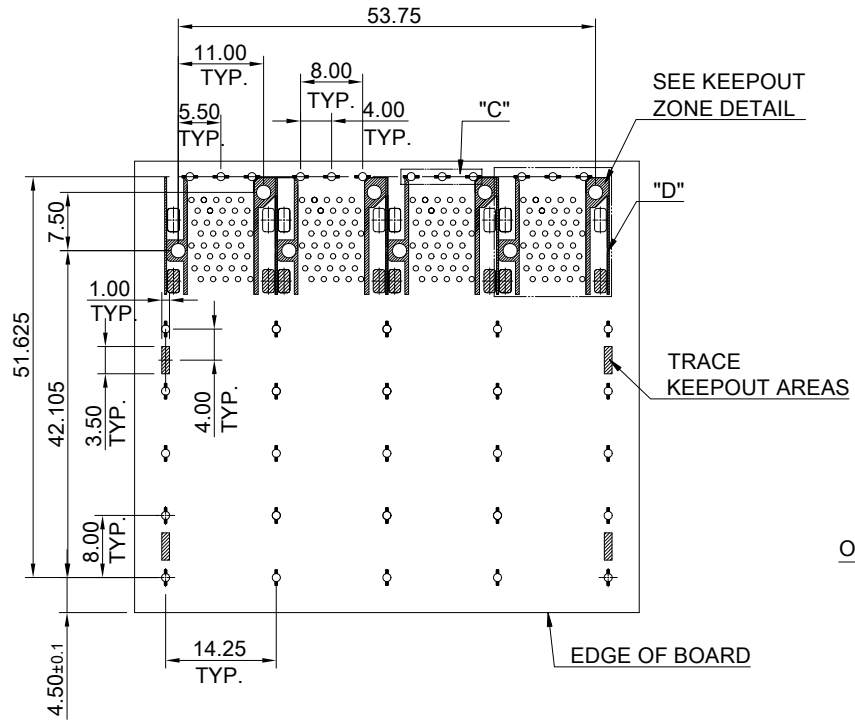

RECOMMENDED PCB LAYOUT
TOLERANCE : ± 0.05
MINIMUM PCB THICKNESS OF 1.57MM

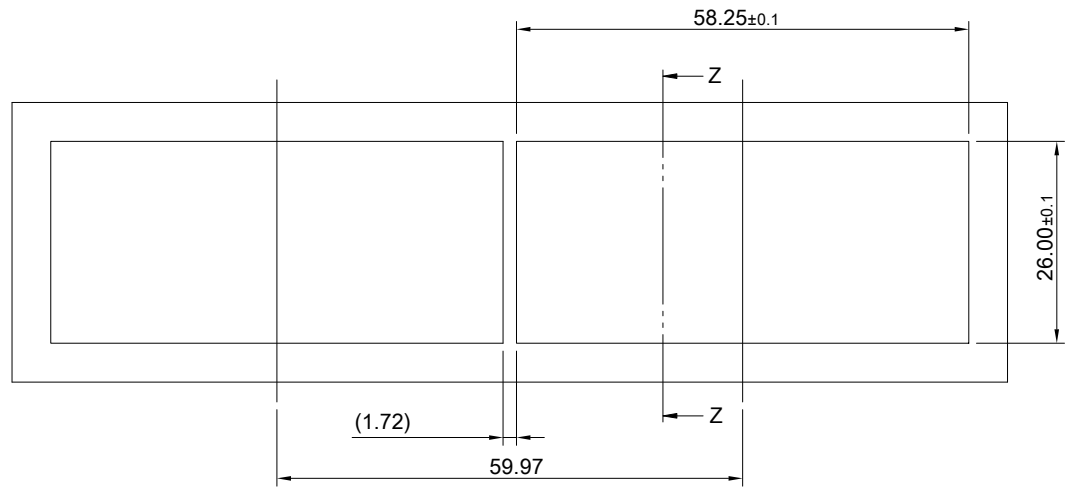
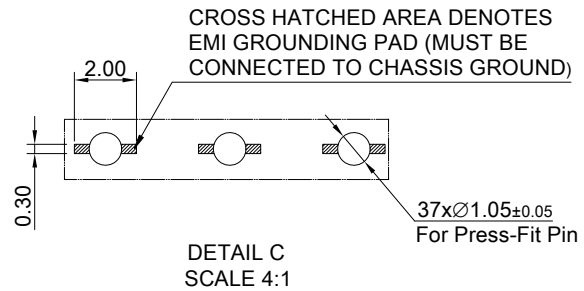

RECOMMENDED BEZEL CUT-OUT SPACING DETAIL
BEZEL THICKNESS 0.8~2.6MM

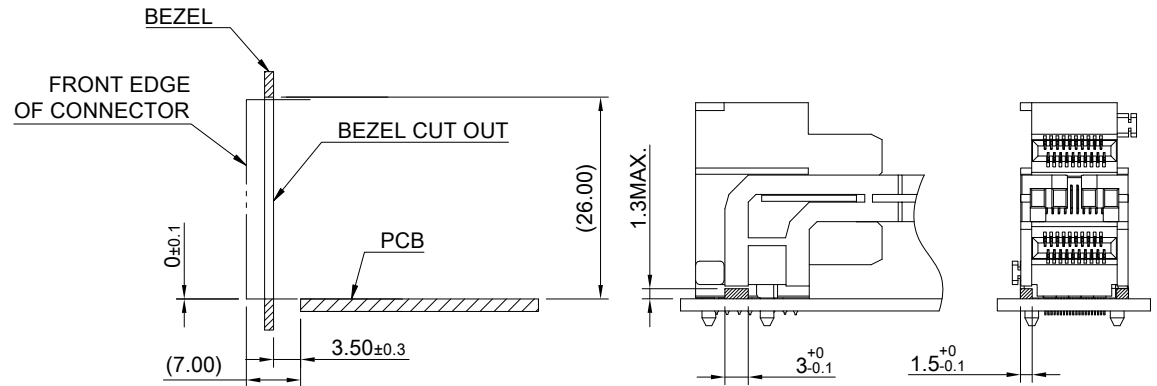

SECTION Z-Z



| | | | |
|---|---------------|--------------------------|-----------------------|
| TITLE: Transformed SFP 2X4 w/ Light Pipe | | | |
| DWG#: R-OP-008160-7-F-N-20 | | SHEET: 2/3 | REV. C |
| UNIT: mm | SCALE: A4 1:1 | CHECKED: Gary Kang | |
| THIRD ANGLE PROJECTION | | MATERIAL: RoHS Compliant | APPROVED: George Yang |
| TOLERANCE: Angle: ± 1° X ± 0.15 .X ± 0.10 .XX ± 0.05 | | DRAWN: Laura | DATE: 04/20/2022 |

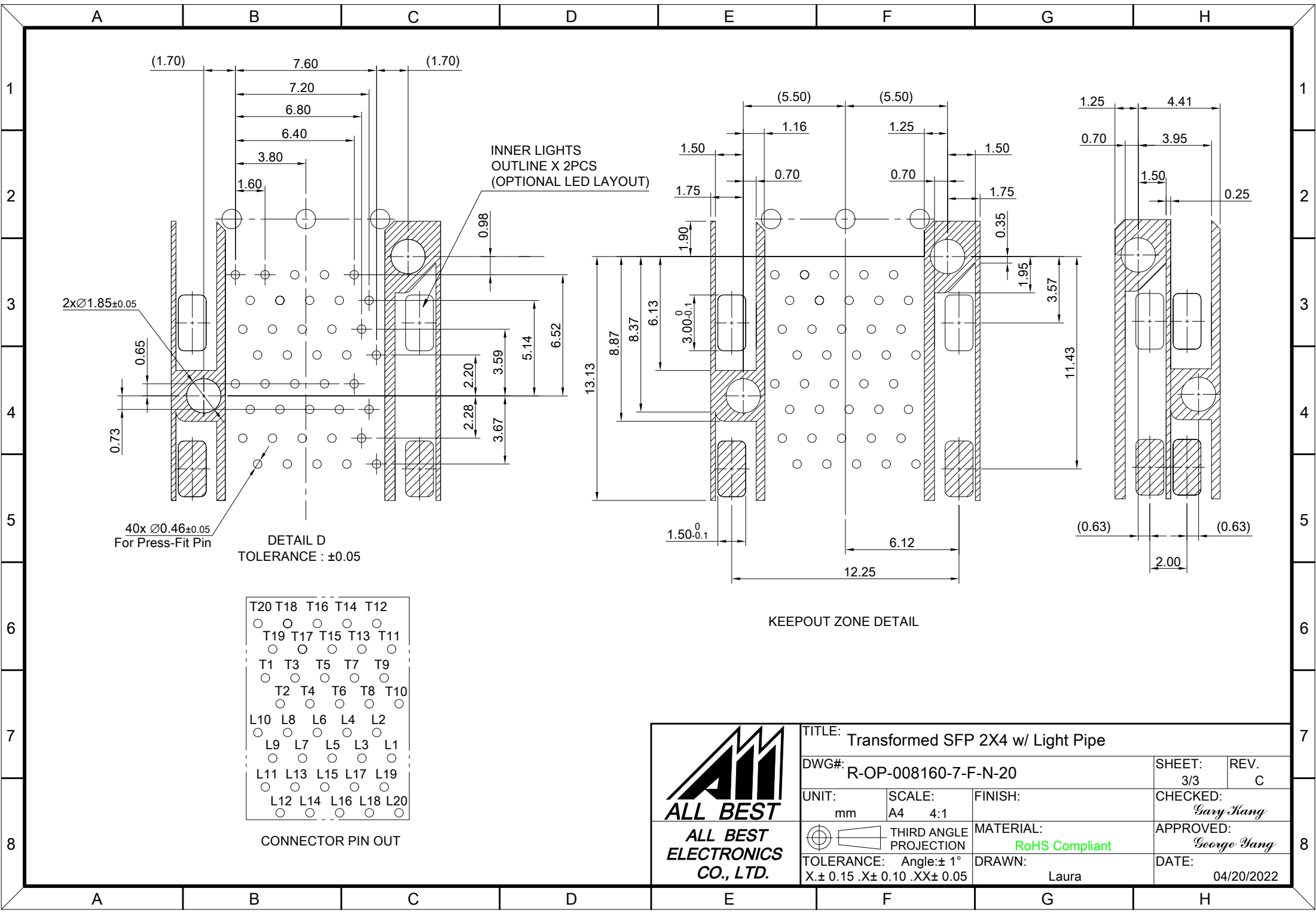

2x $\varnothing 1.85 \pm 0.05$

40x $\varnothing 0.46 \pm 0.05$
For Press-Fit Pin

DETAIL D
TOLERANCE : ± 0.05

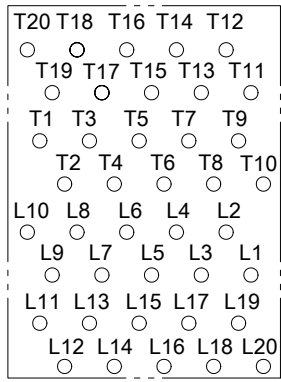

CONNECTOR PIN OUT

INNER LIGHTS
OUTLINE X 2PCS
(OPTIONAL LED LAYOUT)

KEEPOUT ZONE DETAIL



| | | | |
|---|---------------|--------------------------|------------------|
| TITLE: Transformed SFP 2X4 w/ Light Pipe | | | |
| DWG#: R-OP-008160-7-F-N-20 | | SHEET: 3/3 | REV. C |
| UNIT: mm | SCALE: A4 4:1 | FINISH: | |
| THIRD ANGLE PROJECTION | | MATERIAL: RoHS Compliant | |
| TOLERANCE: Angle: $\pm 1^\circ$ X: ± 0.15 .X: ± 0.10 .XX: ± 0.05 | | DRAWN: Laura | DATE: 04/20/2022 |
| | | CHECKED: Gary Kang | |
| | | APPROVED: George Yang | |