

DETAIL A
SCALE: 5:1

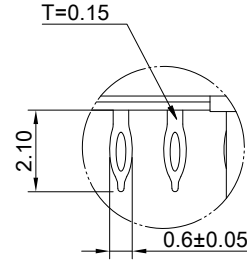

DETAIL B
SCALE: 5:1

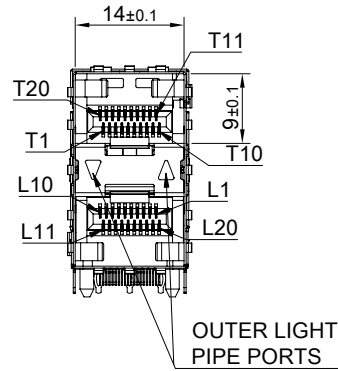
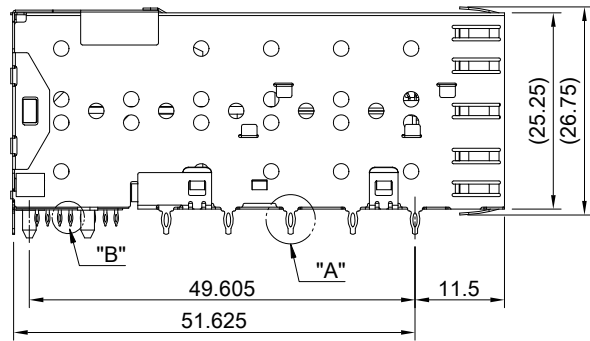
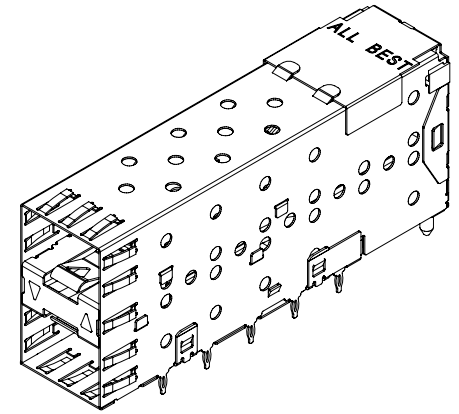

MATERIAL
 CAGE: NICKEL SILVER
 LIGHT PIPE: PC (CLEAR)
 CONNECTOR: PA9T 94V-0 (BLACK)
 LCP 94V-0 (DARK GRAY)
 COPPER ALLOY

FINISH
 CONTACT: 15µ" MIN. GOLD ON MATING END;
 30µ" MIN. MATTE TIN ON TERMINATION END;
 ALL UNDERPLATED 50µ" MIN. NICKEL

ELECTRICAL CHARACTERISTICS
 CONTACT CURRENT RATING: 0.5 AMPERE
 VOLTAGE RATING: 30 VAC
 CONTACT RESISTANCE: 80 mΩ MAX.
 DIELECTRIC WITHSTANDING VOLTAGE: 300VAC

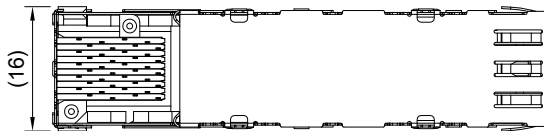

	TITLE: Transformed SFP 2X1 w/ Light Pipe		
	DWG#: R-DP-008040-7-F-N-19		SHEET: 1/3 REV. D
	UNIT: mm	SCALE: A4 1:1	CHECKED: Gary Yang
	THIRD ANGLE PROJECTION TOLERANCE: Angle: ± 1° X.± 0.25 .X± 0.20 .XX± 0.15		APPROVED: George Yang DATE: 06/09/2021
MATERIAL: RoHS Compliant		DRAWN: Laura	

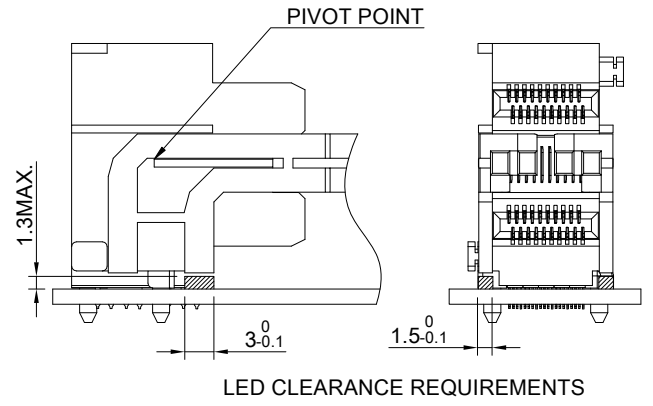
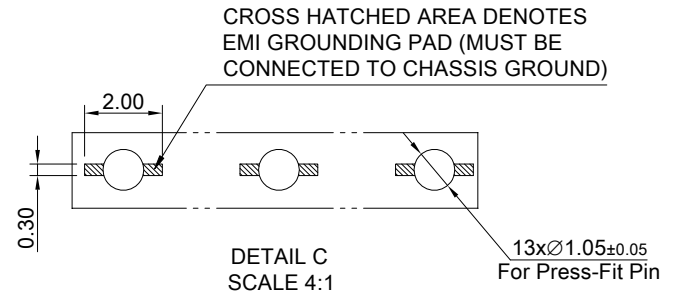
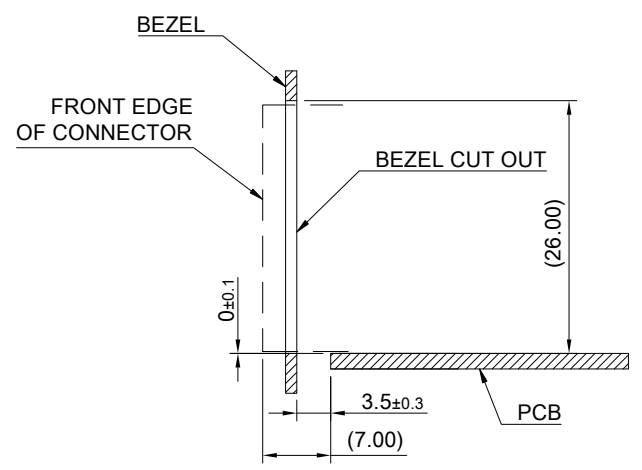
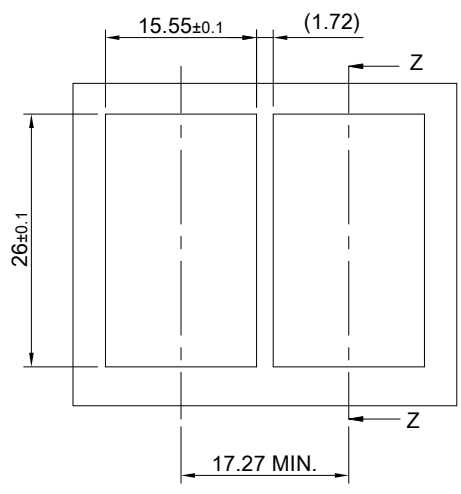
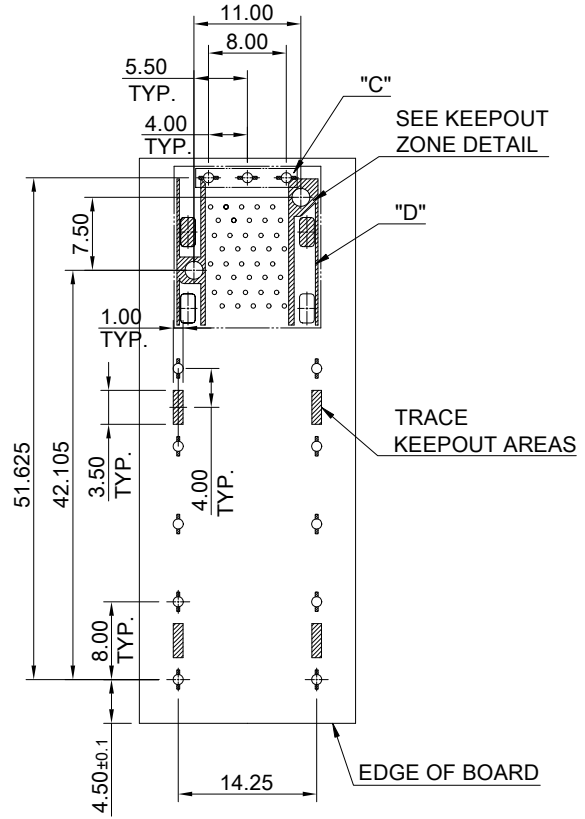

<p>ALL BEST ALL BEST ELECTRONICS CO., LTD.</p>	TITLE: Transformed SFP 2X1 w/ Light Pipe		SHEET: 2/3	REV. D
	DWG#: R-DP-008040-7-F-N-19		CHECKED: Gary Hang	
	UNIT: mm	SCALE: A4 5:4	FINISH:	APPROVED: George Yang
	TOLERANCE: Angle: $\pm 1^\circ$ X. ± 0.15 .X ± 0.10 .XX ± 0.05		MATERIAL: RoHS Compliant	DATE: 06/09/2021
		DRAWN: Laura		

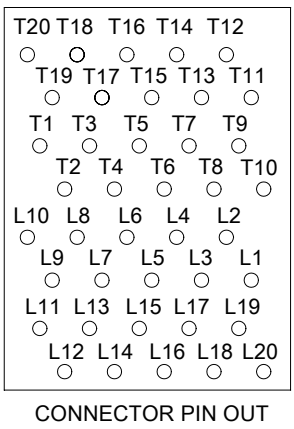
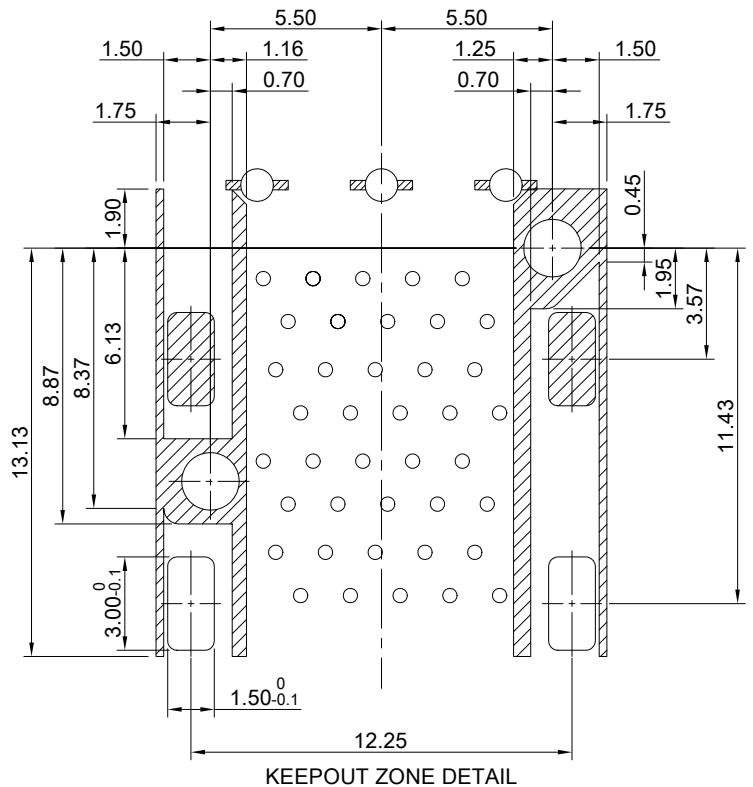
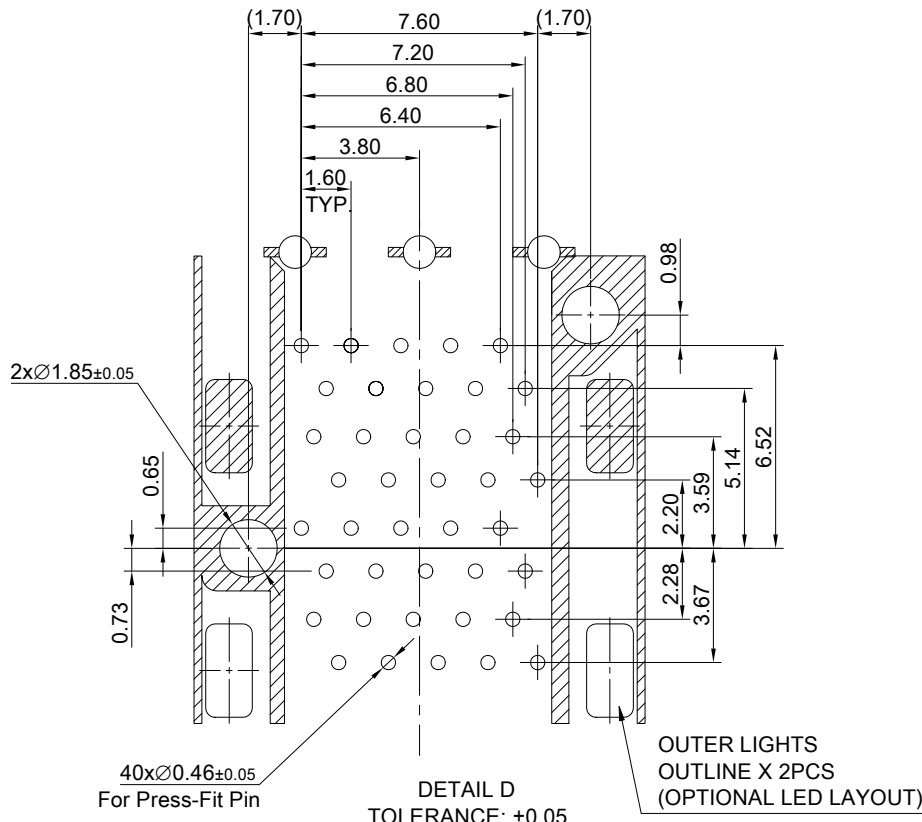

TITLE: Transformed SFP 2X1 w/ Light Pipe			
DWG#: R-DP-008040-7-F-N-19		SHEET: 3/3	REV. D
UNIT: mm	SCALE: A4 4:1	FINISH:	CHECKED: Gary Yang
THIRD ANGLE PROJECTION		MATERIAL: RoHS Compliant	APPROVED: George Yang
TOLERANCE: Angle: ± 1° X ± 0.15 .X ± 0.10 .XX ± 0.05		DRAWN: Laura	DATE: 06/09/2021