

MATERIAL
 CAGE: NICKEL SILVER
 CONNECTOR: PA9T 94V-0 (BLACK)
 LCP 94V-0 (DARK GRAY)
 COPPER ALLOY

FINISH
 CONTACT: 15μ" MIN. GOLD ON MATING END;
 30μ" MIN. TIN ON TERMINATION END;
 ALL UNDERPLATED 50μ" MIN. NICKEL

ELECTRICAL CHARACTERISTICS
 CONTACT CURRENT RATING: 0.5 AMPERE
 VOLTAGE RATING: 30 VAC
 CONTACT RESISTANCE: 80 mΩ MAX.
 DIELECTRIC WITHSTANDING VOLTAGE: 300VAC

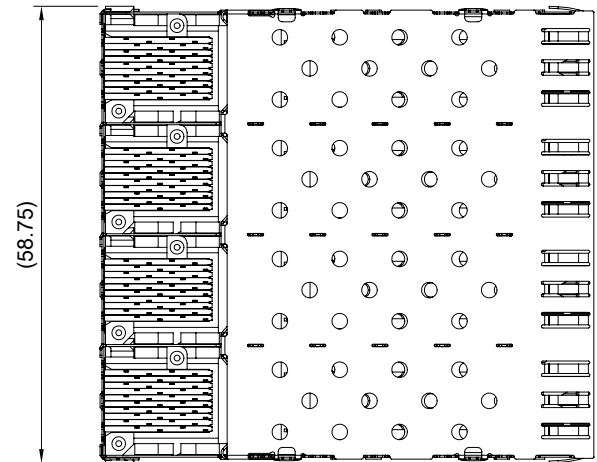

TITLE: Transformed SFP 2X4		SHEET: 1/3	REV.: C
DWG#: R-OP-008160-6-F-N-13		CHECKED: Gary Kang	
UNIT: mm	SCALE: A4 1:1	APPROVED: George Yang	
FINISH: RoHS Compliant		DATE: 06/10/2021	
MATERIAL: RoHS Compliant		DRAWN: Laura	
TOLERANCE: Angle: ± 1° X ± 0.25 .X ± 0.20 .XX ± 0.15			

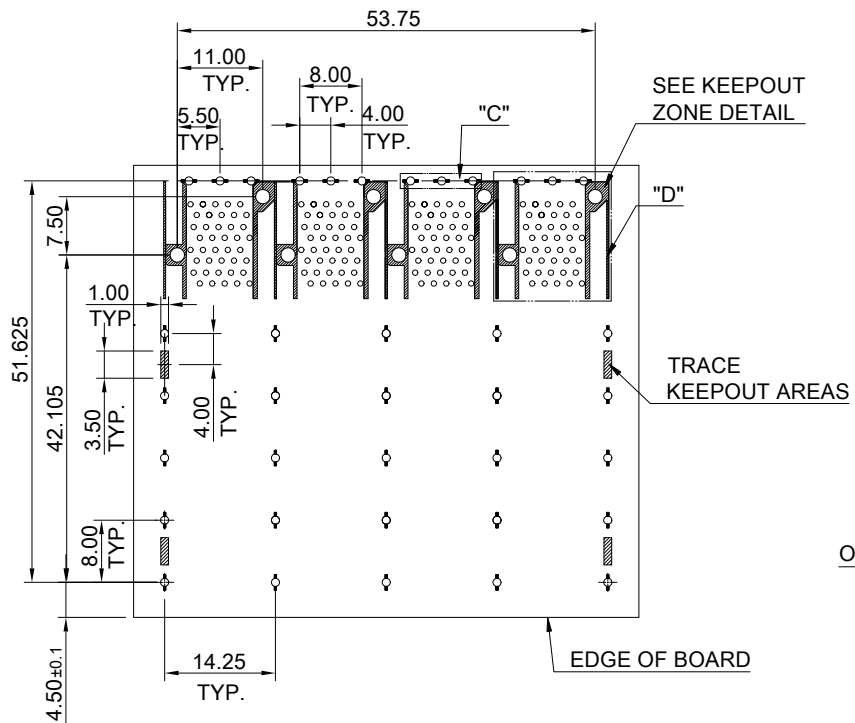

RECOMMENDED PCB LAYOUT
TOLERANCE : ± 0.05
MINIMUM PCB THICKNESS OF 1.57MM

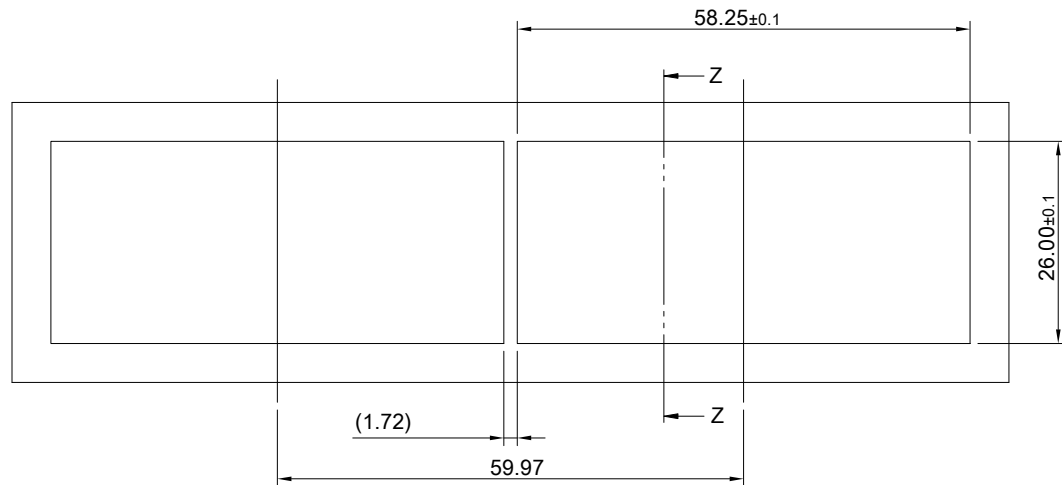
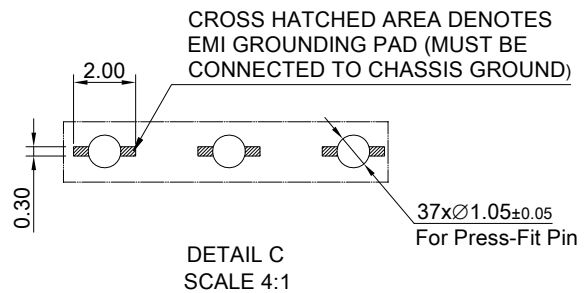

RECOMMENDED BEZEL CUT-OUT SPACING DETAIL
BEZEL THICKNESS 0.8-2.6MM

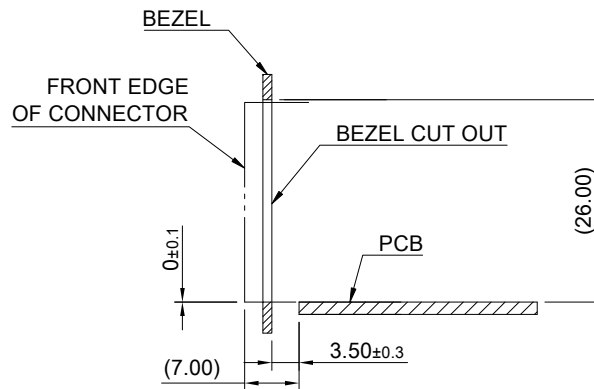

SECTION Z-Z

<p>ALL BEST ELECTRONICS CO., LTD.</p>	TITLE: Transformed SFP 2X4		SHEET: 2/3	REV. C
	DWG#: R-OP-008160-6-F-N-13		CHECKED: Gary Kang	
	UNIT: mm	SCALE: A4 1:1	FINISH:	APPROVED: George Yang
	TOLERANCE: X± 0.15 .X± 0.10 .XX± 0.05		MATERIAL: RoHS Compliant	DATE: 06/10/2021
THIRD ANGLE PROJECTION		DRAWN: Laura		

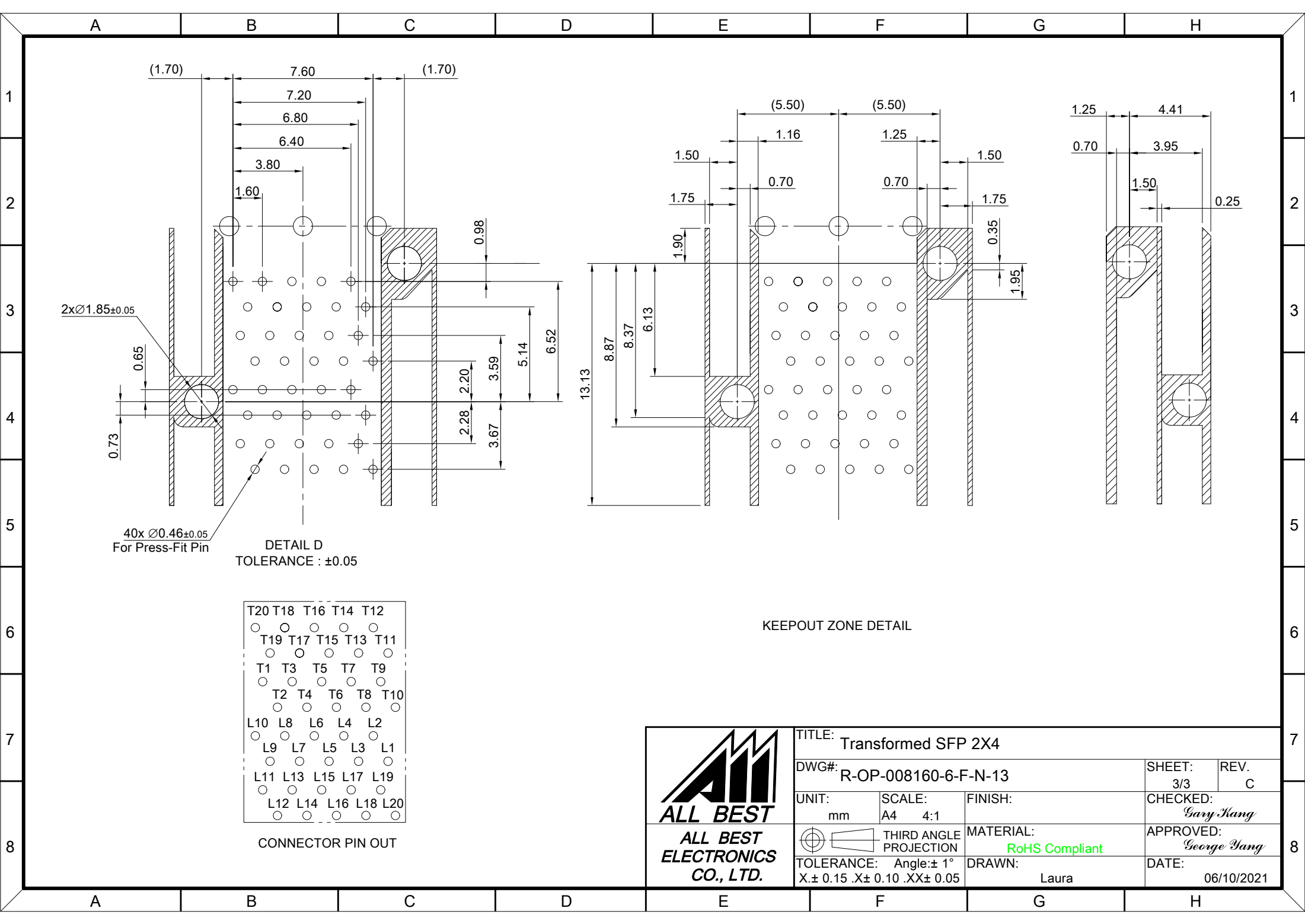

2x $\varnothing 1.85 \pm 0.05$

DETAIL D
TOLERANCE : ± 0.05

40x $\varnothing 0.46 \pm 0.05$
For Press-Fit Pin

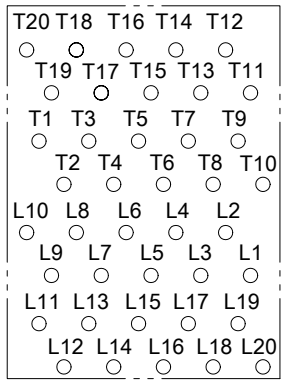

CONNECTOR PIN OUT

KEEPOUT ZONE DETAIL



TITLE: Transformed SFP 2X4			
DWG#: R-OP-008160-6-F-N-13		SHEET: 3/3	REV. C
UNIT: mm	SCALE: A4 4:1	FINISH:	CHECKED: Gary Kang
THIRD ANGLE PROJECTION		MATERIAL: RoHS Compliant	APPROVED: George Yang
TOLERANCE: Angle: $\pm 1^\circ$ X: ± 0.15 .X: ± 0.10 .XX: ± 0.05		DRAWN: Laura	DATE: 06/10/2021