

DETAIL A
SCALE 4:1

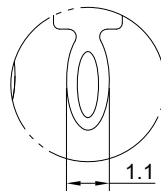

DETAIL B
SCALE 4:1

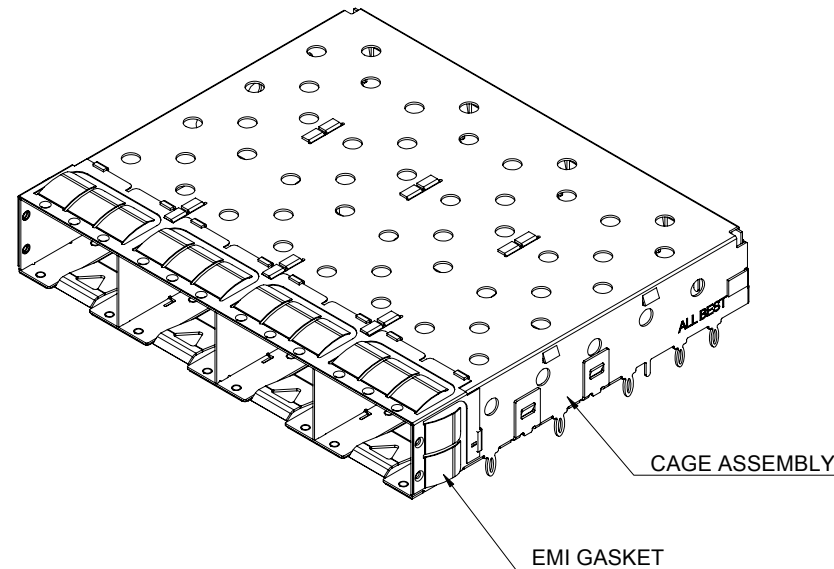

MATERIAL
CAGE: NICKEL SILVER
EMI GASKET: STAINLESS STEEL

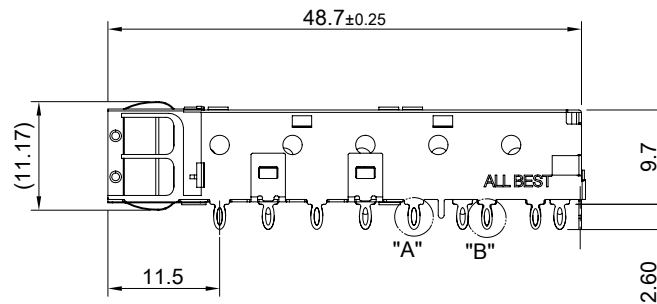
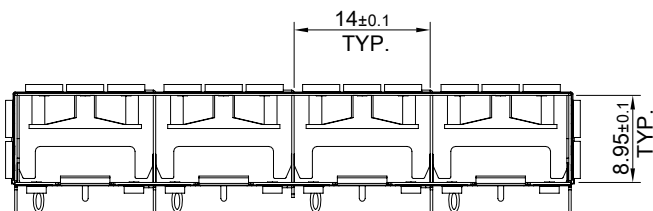

	TITLE: SFP+ 1X4 Cage Assembly w/ EMI Metal Gasket			SHEET: 1/4		REV. F	
	DWG#: R-SH-008080-6-F-22			CHECKED: Gary Kang		APPROVED: George Yang	
	UNIT: mm	SCALE: A4 5:4	FINISH:	MATERIAL: RoHS Compliant		DATE: 05/11/2020	
	TOLERANCE: X.± 0.25 .X± 0.20 .XX± 0.15		THIRD ANGLE PROJECTION	DRAWN: Jun			

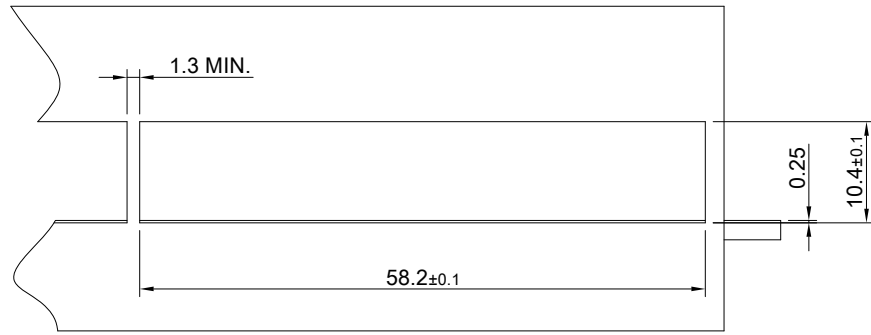

RECOMMENDED BEZEL CUT-OUT
SINGLE SIDED APPLICATIONS

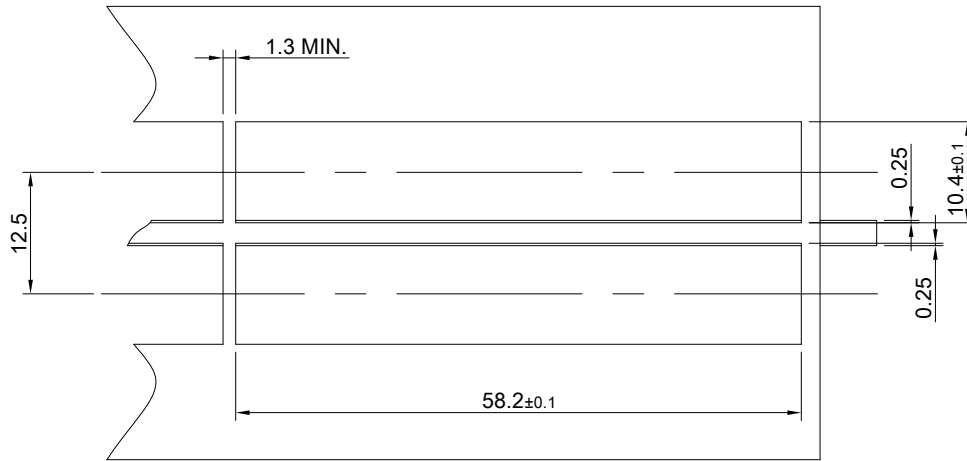
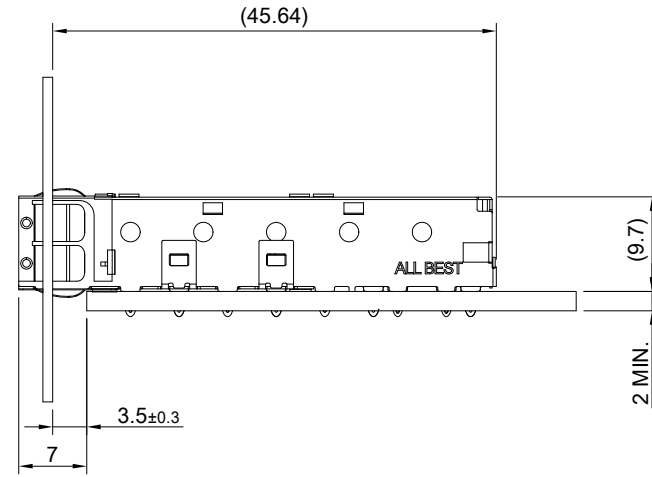

RECOMMENDED BEZEL CUT-OUT
BELLY TO BELLY APPLICATIONS

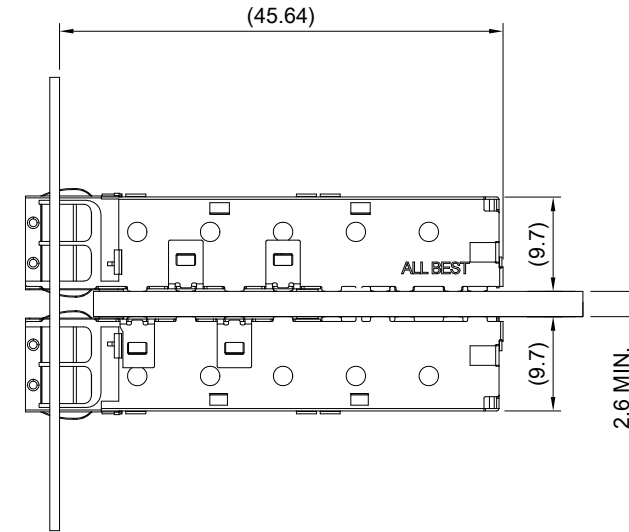

	TITLE: SFP+ 1X4 Cage Assembly w/ EMI Metal Gasket			SHEET: 2/4	REV. F	
	DWG#: R-SH-008080-6-F-22				CHECKED: Gary Kang	
	UNIT: mm	SCALE: A4 5:4	FINISH:	APPROVED: George Yang		
	TOLERANCE: Angle: ± 1° X ± 0.15 .X ± 0.10 .XX ± 0.05		MATERIAL: RoHS Compliant	DATE: 05/11/2020		
THIRD ANGLE PROJECTION		DRAWN: Jun				

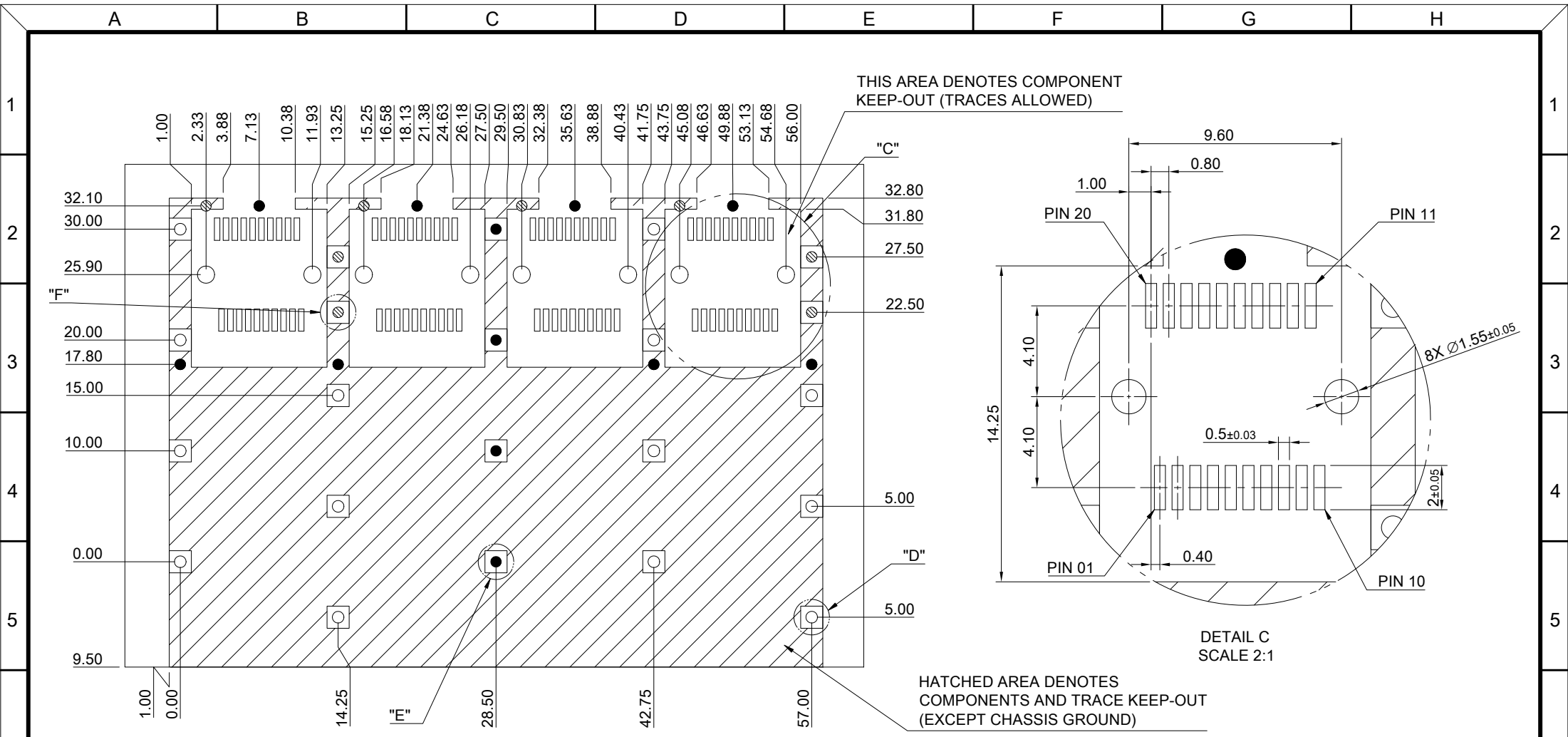

RECOMMENDED PCB LAYOUT
TOLERANCE: ±0.05

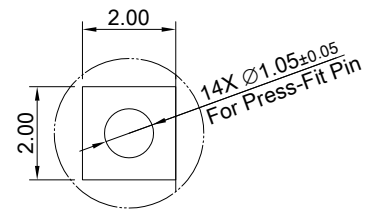

DETAIL D
SCALE 3:1

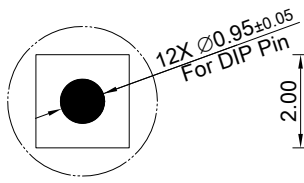

DETAIL E
SCALE 3:1

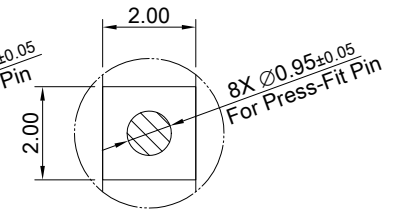

DETAIL F
SCALE 3:1



TITLE: SFP+ 1X4 Cage Assembly w/ EMI Metal Gasket			
DWG#: R-SH-008080-6-F-22		SHEET: 3/4	REV. F
UNIT: mm	SCALE: A4 2:1	FINISH:	CHECKED: Gary Kang
THIRD ANGLE PROJECTION		MATERIAL: RoHS Compliant	APPROVED: George Yang
TOLERANCE: Angle: ±1° X ± 0.15 .X ± 0.10 .XX ± 0.05		DRAWN: Jun	DATE: 05/11/2020

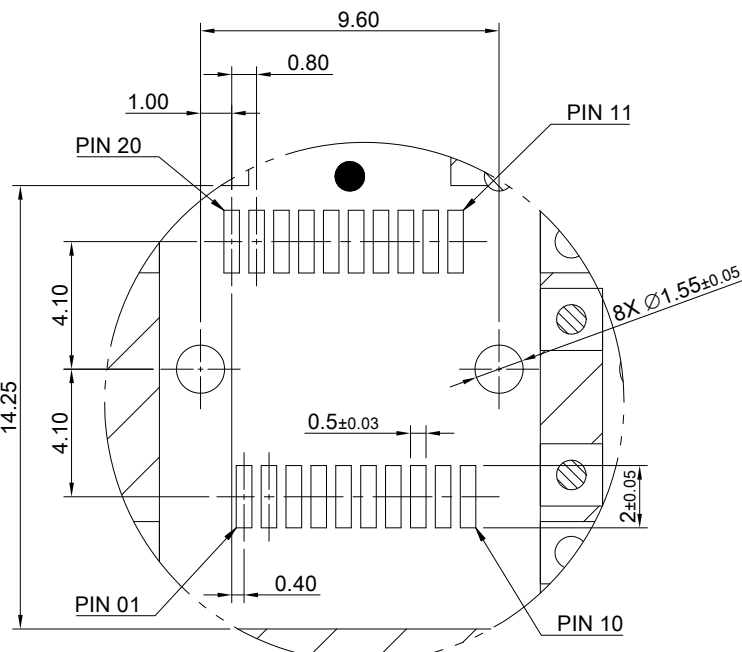
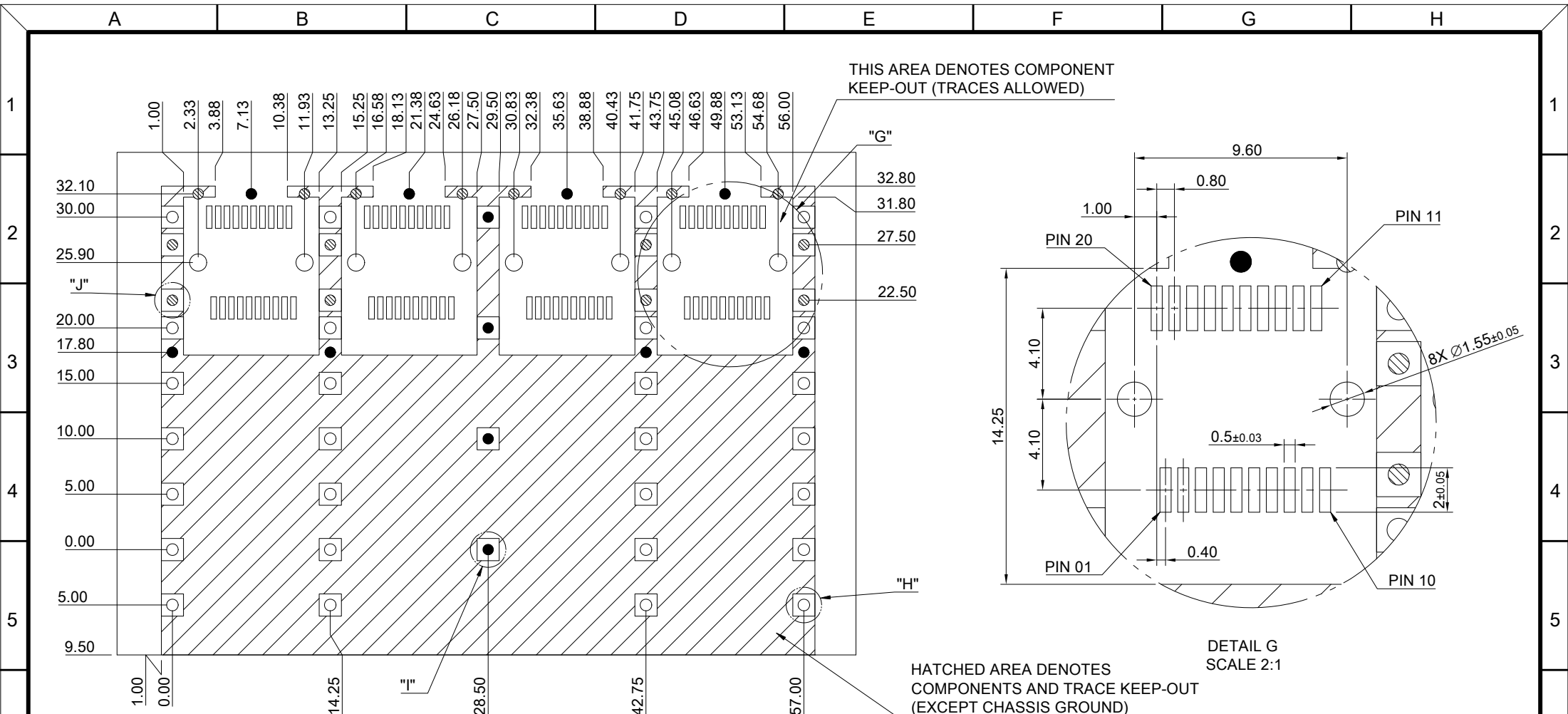

DETAIL G
SCALE 2:1

RECOMMENDED PCB LAYOUT
FOR BELLY TO BELLY MOUNTING
TOLERANCE: ±0.05

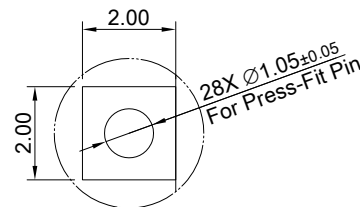

DETAIL H
SCALE 3:1

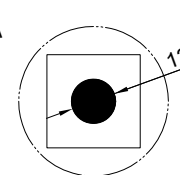

DETAIL I
SCALE 3:1

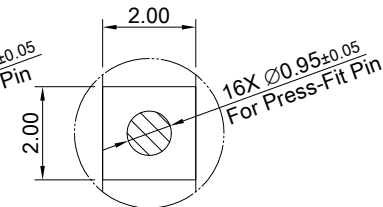

DETAIL J
SCALE 3:1



TITLE: SFP+ 1X4 Cage Assembly w/ EMI Metal Gasket			
DWG#: R-SH-008080-6-F-22		SHEET: 4/4	REV. F
UNIT: mm	SCALE: A4 2:1	FINISH:	CHECKED: Gary Kang
THIRD ANGLE PROJECTION		MATERIAL: RoHS Compliant	APPROVED: George Yang
TOLERANCE: Angle: ± 1° X ± 0.15 .X ± 0.10 .XX ± 0.05		DRAWN: Jun	DATE: 05/11/2020