

A B C D E F G H

1  
2  
3  
4  
5  
6  
7  
8

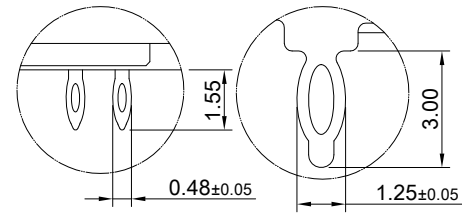
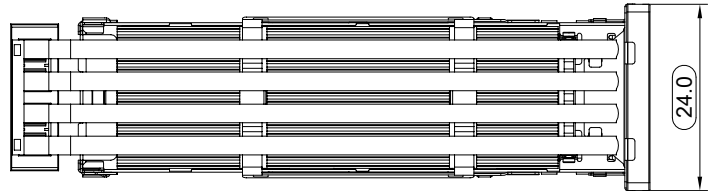

DETAIL B  
SCALE 5:1

DETAIL A  
SCALE 5:1

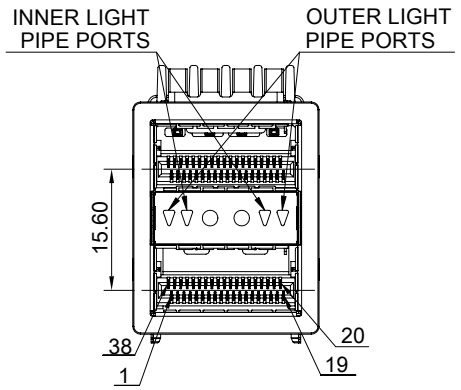
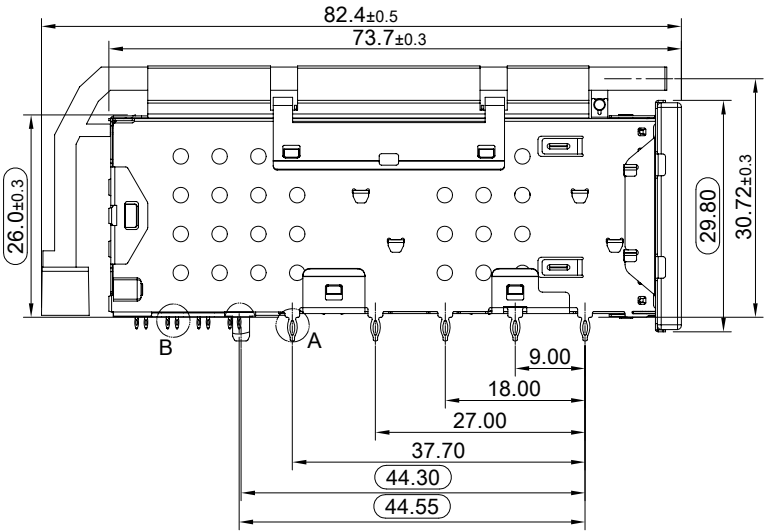
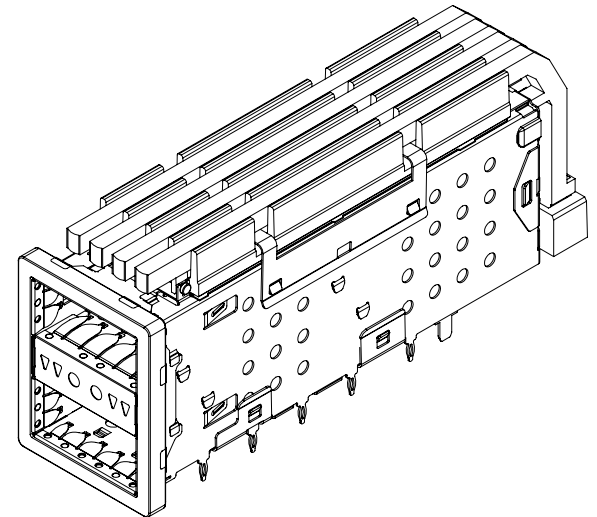

**MATERIAL**  
 CAGE: NICKEL SILVER  
 CONNECTOR HOUSING: THERMOPLASTIC, UL 94V-0  
 EMI SPRING: STAINLESS STEEL  
 CONTACTS: COPPER ALLOY  
 EMI GASKET FLANGE: STAINLESS STEEL  
 EMI GASKET: CONDUCTIVE ELASTOMER(UGTP)  
 HEAT SINK: ALUMINUM  
 HEAT SINK CLIP: STAINLESS STEEL  
 LIGHT PIPE: PC  
 LIGHT SHIELD: THERMOPLASTIC

**FINISH**  
 HEAT SINK: ANODE PROCESS  
 CONTACT: 15µ" MIN. GOLD ON MATING END;  
 30µ" MIN. MATTE TIN ON TERMINAL END;  
 ALL UNDERPLATED 50µ" MIN. NICKEL

**ELECTRICAL CHARACTERISTICS**  
 CONTACT CURRENT RATING: 0.5AMPERE  
 VOLTAGE RATING: 30VAC  
 CONTACT RESISTANCE: 80 mΩ MAX.  
 DIELECTRIC WITHSTANDING VOLTAGE: 300VAC

THIS PRINT IS  
**PRELIMINARY**  
 UNQUALIFIED PRODUCT  
 CONTACT PRODUCT ENGINEERING  
 BEFORE USING THIS PRINT



TITLE: Stacked QSFP+ Enhance 2x1 Assembly w/ Internal/ External Light Pipe & Heat Sink			
DWG#: R-TR-QEL1-4CGLJ-AIO-4		SHEET: 1/2	REV. REF.
UNIT: mm	SCALE: A4 1:1	FINISH:	CHECKED:
THIRD ANGLE PROJECTION		MATERIAL: RoHS Compliant	APPROVED:
TOLERANCE: Angle: ± 1° X.±0.25 .X±0.20 .XX±0.15		DRAWN: Allen	DATE: 03/14/2024

A B C D E F G H

TRACE KEEP-OUT ZONE  
AROUND PRESS-FIT TAIL HOLES

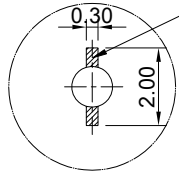

DETAIL D  
SCALE 5:1

INNER LIGHTS OUTLINE  
(OPTIONAL LED LAYOUT)

OUTER LIGHTS OUTLINE  
(OPTIONAL LED LAYOUT)

CONNECTOR AREA  
SEE NOTE 1

TRACE KEEP-OUT ZONE

RECOMMENDED PCB LAYOUT  
TOLERANCE:  $\pm 0.05$   
MINIMUM PCB THICKNESS OF 1.57MM

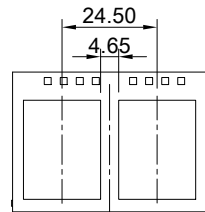
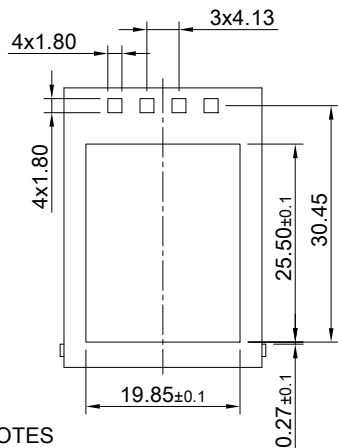

NOTES

1. THE ENTIRE AREA UNDER THE CONNECTOR CAGE IS A COMPONENT KEEP-OUT ZONE. THE AREA UNDER THE CONNECTOR MODULE IS A TRACE KEEP-OUT AREA.
2. HATCHED AREAS REPRESENT ZONES ON THE PCB THAT COME IN CONTACT WITH OR BE IN CLOSE PROXIMITY TO THE PLASTIC HOUSING OR THE CONNECTOR CAGE. INDICATED AREAS TO BE CONSIDERED TRACE FREE.
3. MIN. DISTANCE FROM THE TOP SIDE OF PCB TO LIGHT PIPE.  
SMD LED HIGHLY RECOMMENDED : 0.8mm(MIN.)~1.2mm(MAX.).  
THE VIEWING ANGLE SUGGESTED IS  $<60^\circ$

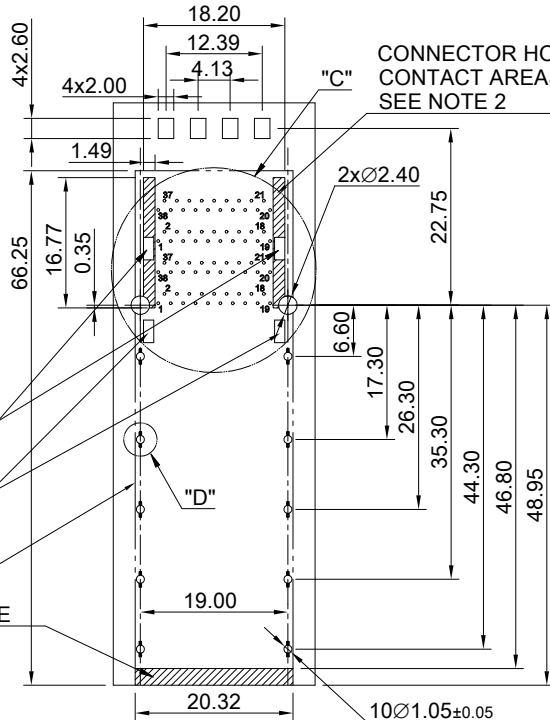

CONNECTOR HOUSING  
CONTACT AREAS  
SEE NOTE 2

76x∅0.37±0.05  
(For Press-Fit Pin)

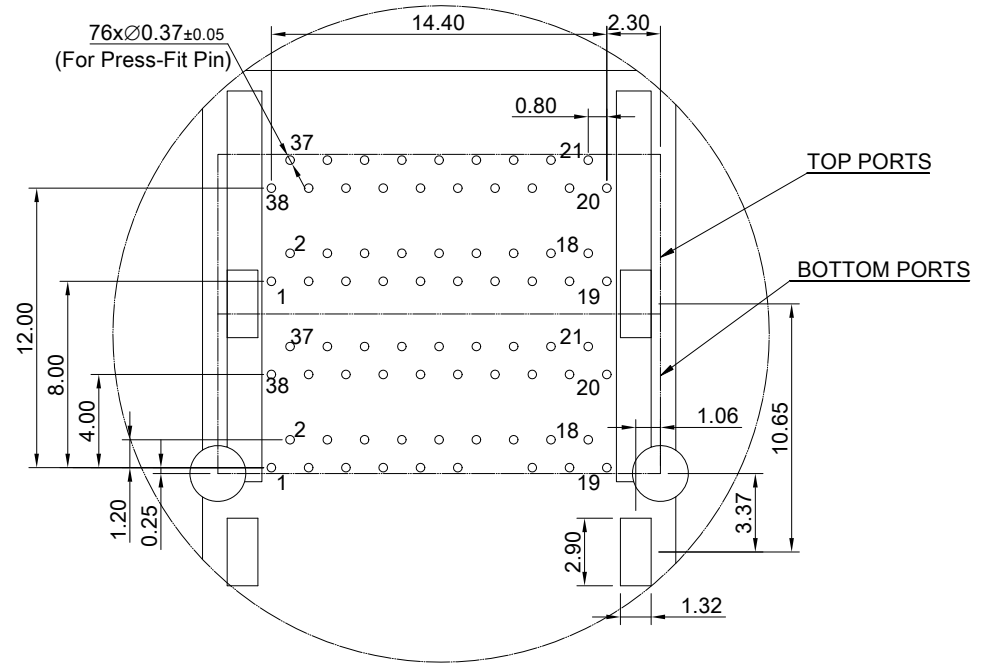

DETAIL C  
SCALE 3:1

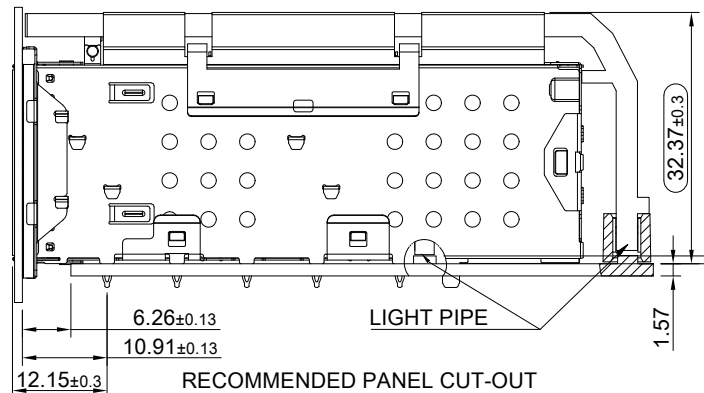

RECOMMENDED PANEL CUT-OUT

SEE NOTE 3

THIS PRINT IS  
**PRELIMINARY**  
UNQUALIFIED PRODUCT  
CONTACT PRODUCT ENGINEERING  
BEFORE USING THIS PRINT



TITLE: Stacked QSFP+ Enhance 2x1 Assembly w/ Internal/ External Light Pipe & Heat Sink			
DWG#: R-TR-QEL1-4CGLJ-AIO-4		SHEET: 2/2	REV. REF.
UNIT: mm	SCALE: A4 1:1	FINISH:	CHECKED:
TOLERANCE: Angle: $\pm 1^\circ$ X.±0.15 .X±0.1 .XX±0.05		MATERIAL: RoHS Compliant	APPROVED:
		DRAWN: Allen	DATE: 03/14/2024