

DETAIL A
SCALE 5:1

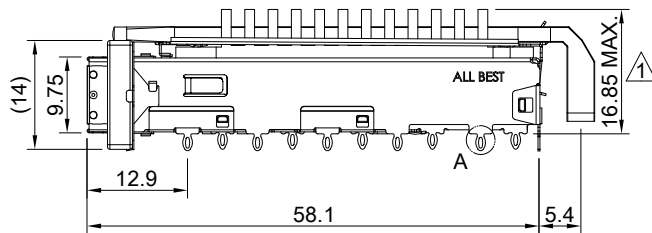
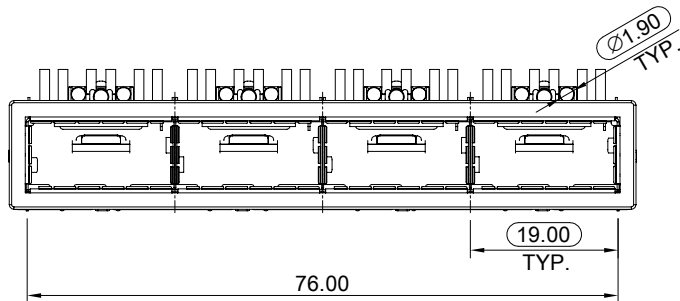
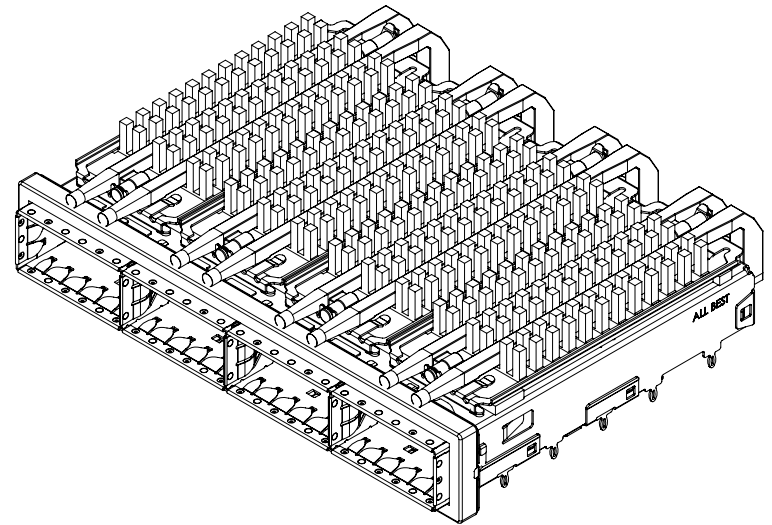

MATERIAL
 CAGE: NICKEL SILVER
 HEAT SINK: ALUMINUM
 HEAT SINK CLIP: STAINLESS STEEL
 EMI SPRING: STAINLESS STEEL
 EMI GASKET: CONDUCTIVE ELASTOMER
 EMI GASKET FLANGE: STAINLESS STEEL
 LIGHT PIPE: PC

FINISH
 HEAT SINK: ANODE PROCESS

NOTE
 ▲ DIMENSION APPLIES WITH MODULE INSERTED IN CAGE

	TITLE: QSFP+ 1X4 Cage Assembly w/ Light Pipe & Heat Sink		
	DWG#: R-OR-Q4-4CGE4		SHEET: 1/4
	UNIT: mm	SCALE: A4 1:1	REV. D
	THIRD ANGLE PROJECTION TOLERANCE: Angle: ± 1° X ± 0.25 .X ± 0.20 .XX ± 0.15		CHECKED: Gary Kang
MATERIAL: RoHS Compliant		APPROVED: George Yang	
DRAWN: Howard		DATE: 05/28/2021	

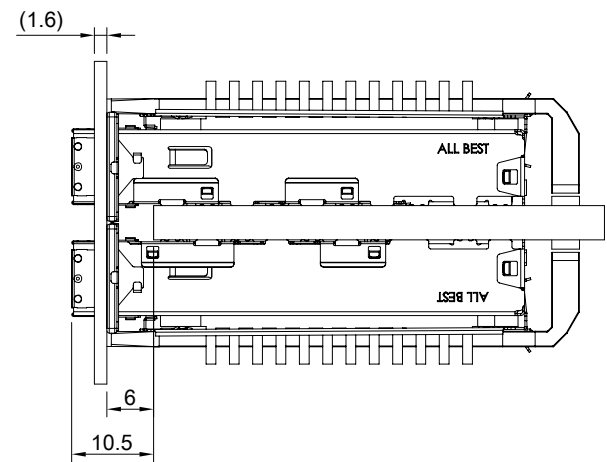
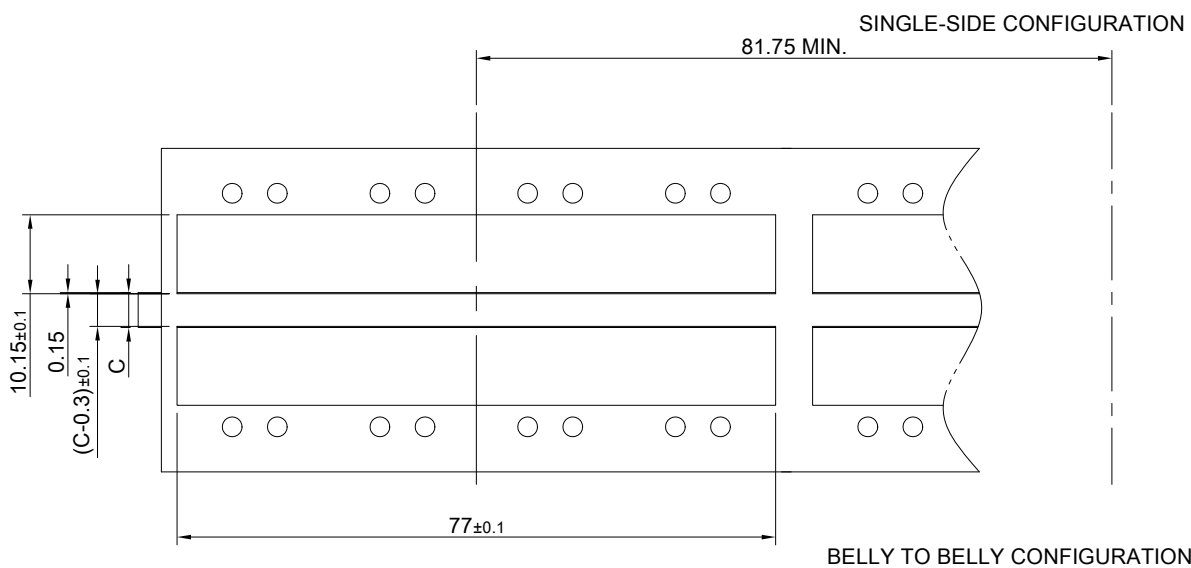
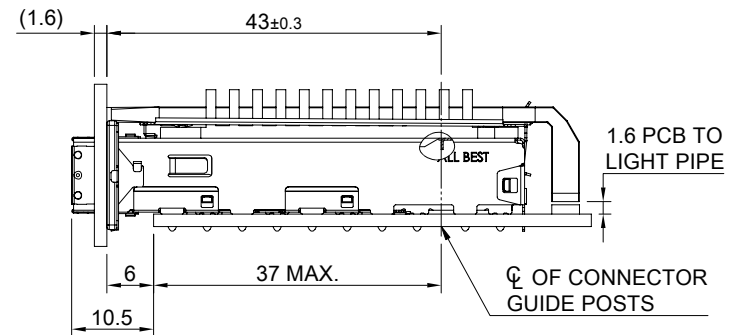
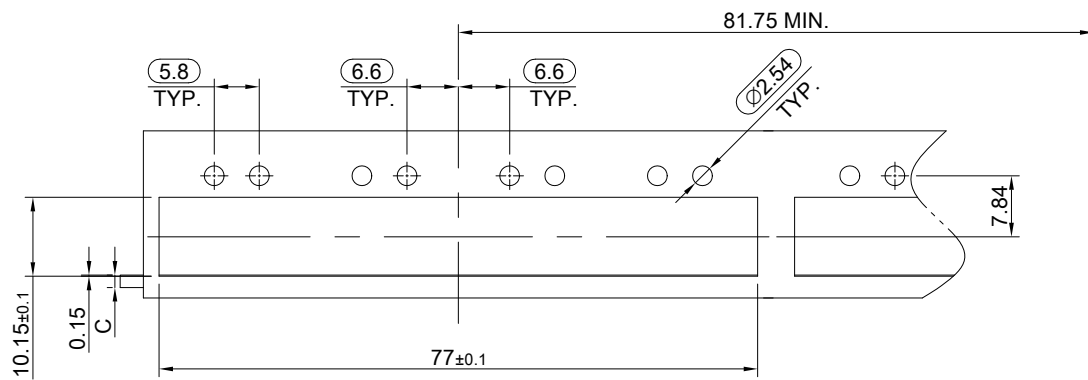

C = THICKNESS OF PC BOARD
 SINGLE-SIDE = 1.6MM (MIN.)
 BELLY TO BELLY = 4.4MM (MIN.)



TITLE: QSFP+ 1X4 Cage Assembly w/ Light Pipe & Heat Sink

DWG#: R-OR-Q4-4CGE4

UNIT: mm SCALE: A4 1:1 FINISH: MATERIAL: RoHS Compliant

TOLERANCE: Angle: ± 1° DRAWN: Howard DATE: 05/28/2021

X.± 0.15 .X± 0.10 .XX± 0.05

SHEET: 2/4 REV. D
 CHECKED: Gary Kang
 APPROVED: George Yang

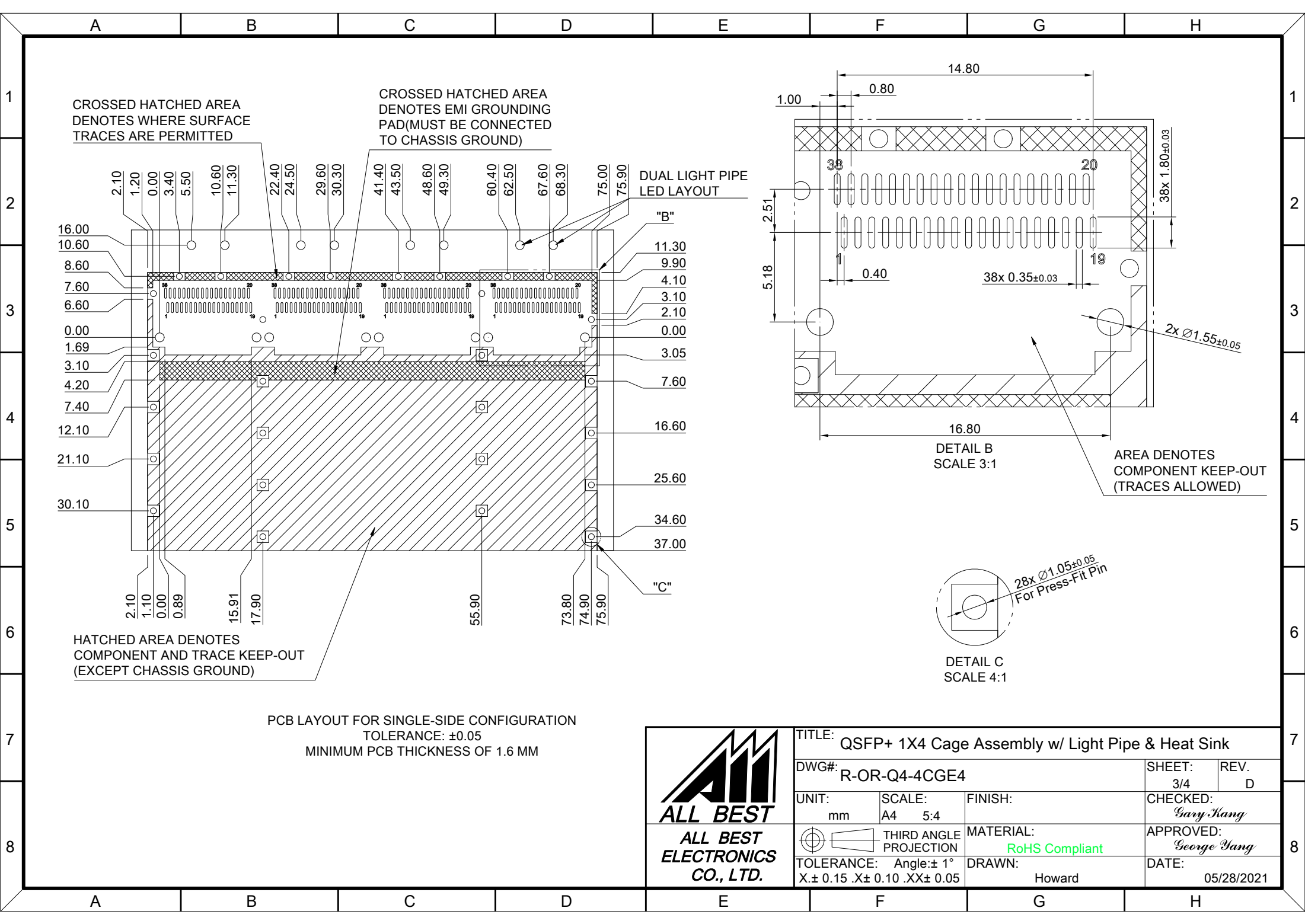

CROSSED HATCHED AREA DENOTES WHERE SURFACE TRACES ARE PERMITTED

CROSSED HATCHED AREA DENOTES EMI GROUNDING PAD (MUST BE CONNECTED TO CHASSIS GROUND)

DUAL LIGHT PIPE LED LAYOUT

HATCHED AREA DENOTES COMPONENT AND TRACE KEEP-OUT (EXCEPT CHASSIS GROUND)

PCB LAYOUT FOR SINGLE-SIDE CONFIGURATION
TOLERANCE: ±0.05
MINIMUM PCB THICKNESS OF 1.6 MM

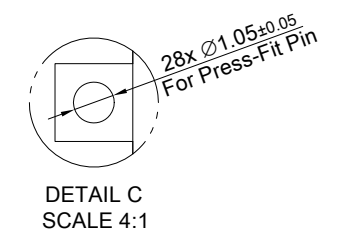
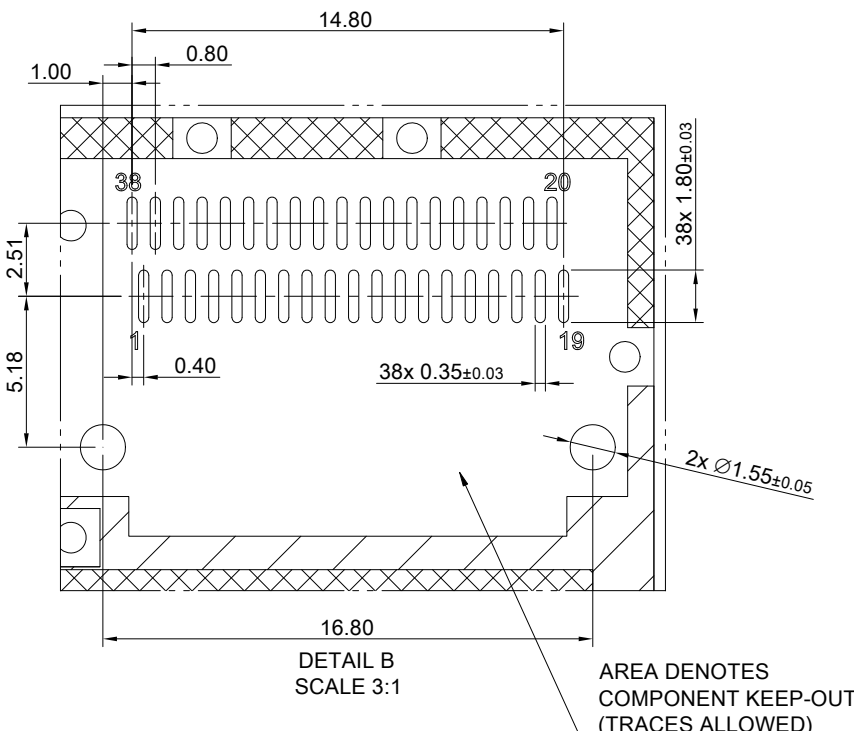

TITLE: QSFP+ 1X4 Cage Assembly w/ Light Pipe & Heat Sink			
DWG#: R-OR-Q4-4CGE4		SHEET: 3/4	REV. D
UNIT: mm	SCALE: A4 5:4	FINISH:	CHECKED: Gary Kang
THIRD ANGLE PROJECTION		MATERIAL: RoHS Compliant	APPROVED: George Yang
TOLERANCE: Angle: ±1° X ± 0.15 .X ± 0.10 .XX ± 0.05		DRAWN: Howard	DATE: 05/28/2021

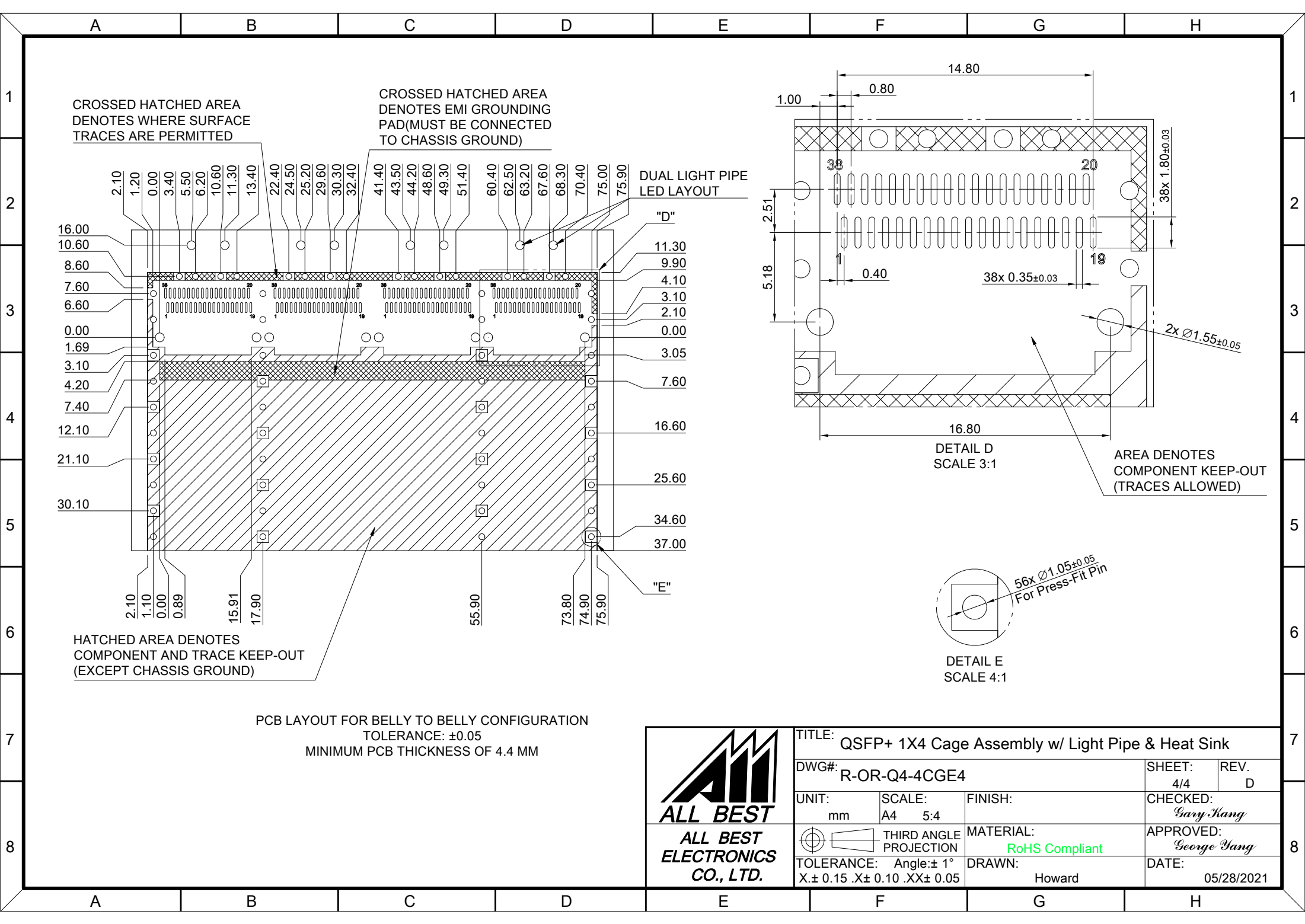

CROSSED HATCHED AREA DENOTES WHERE SURFACE TRACES ARE PERMITTED

CROSSED HATCHED AREA DENOTES EMI GROUNDING PAD (MUST BE CONNECTED TO CHASSIS GROUND)

DUAL LIGHT PIPE LED LAYOUT

HATCHED AREA DENOTES COMPONENT AND TRACE KEEP-OUT (EXCEPT CHASSIS GROUND)

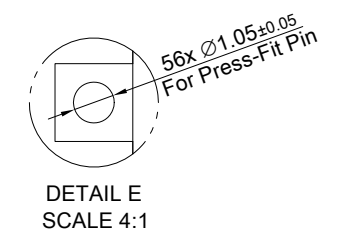
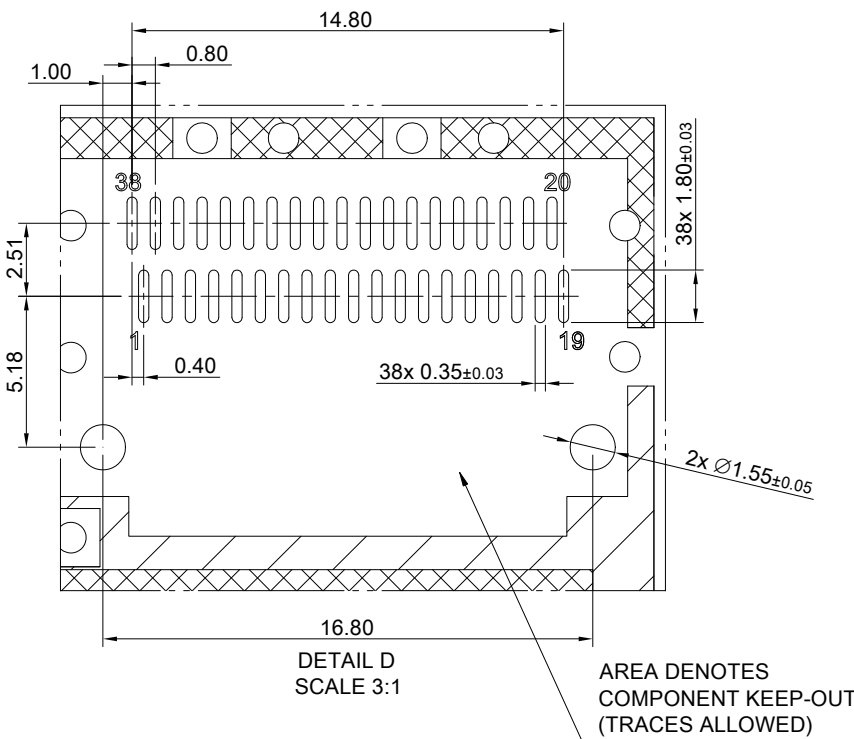

PCB LAYOUT FOR BELLY TO BELLY CONFIGURATION
TOLERANCE: ±0.05
MINIMUM PCB THICKNESS OF 4.4 MM

		TITLE: QSFP+ 1X4 Cage Assembly w/ Light Pipe & Heat Sink	
		DWG#: R-OR-Q4-4CGE4	SHEET: 4/4 REV. D
UNIT: mm	SCALE: A4 5:4	FINISH:	CHECKED: Gary Kang
		MATERIAL: RoHS Compliant	APPROVED: George Yang
TOLERANCE: Angle: ± 1° X ± 0.15 .X ± 0.10 .XX ± 0.05		DRAWN: Howard	DATE: 05/28/2021