

DETAIL A
SCALE 5:1

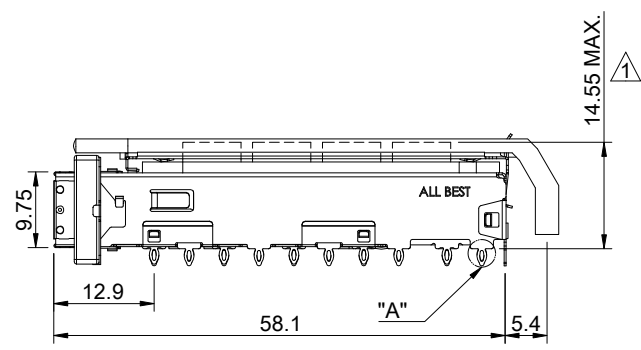
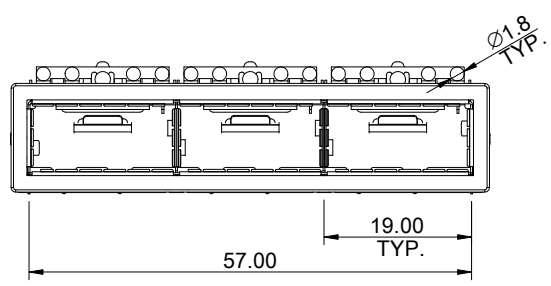
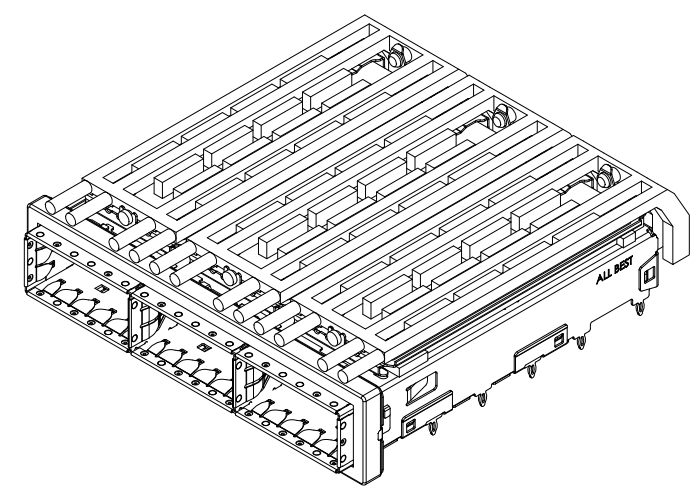

- MATERIAL**
 CAGE: NICKEL SILVER
 HEAT SINK: ALUMINUM
 HEAT SINK CLIP: STAINLESS STEEL
 EMI SPRING: STAINLESS STEEL
 EMI GASKET FLANGE: STAINLESS STEEL
 EMI GASKET: CONDUCTIVE ELASTOMER
 LIGHT PIPE: PC

- FINISH**
 HEAT SINK: ANODE PROCESS

NOTE
 ▲ DIMENSION APPLIES WITH MODULE INSERTED IN CAGE

THIS PRINT IS
PRELIMINARY
 UNQUALIFIED PRODUCT
 CONTACT PRODUCT ENGINEERING
 BEFORE USING THIS PRINT



TITLE: QSFP+ 1X3 Cage Assembly w/ Light Pipe & Heat Sink			
DWG#: R-OR-Q3-4CGEG		SHEET: 1/4	REV. REF
UNIT: mm	SCALE: A4 1:1	CHECKED:	
THIRD ANGLE PROJECTION TOLERANCE: Angle: ± 1° X.± 0.25 .X± 0.20 .XX± 0.15		MATERIAL: RoHS Compliant	APPROVED:
DRAWN: Gary		DATE: 03/15/2024	

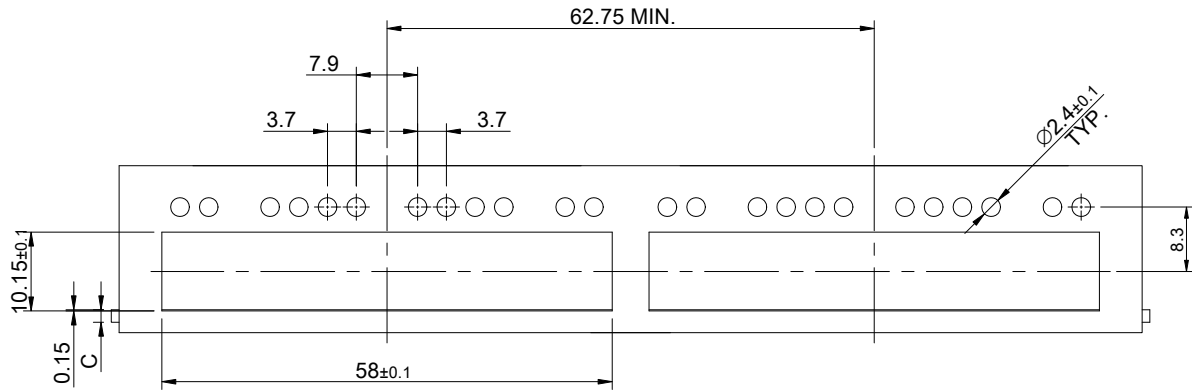

SINGLE-SIDE CONFIGURATION

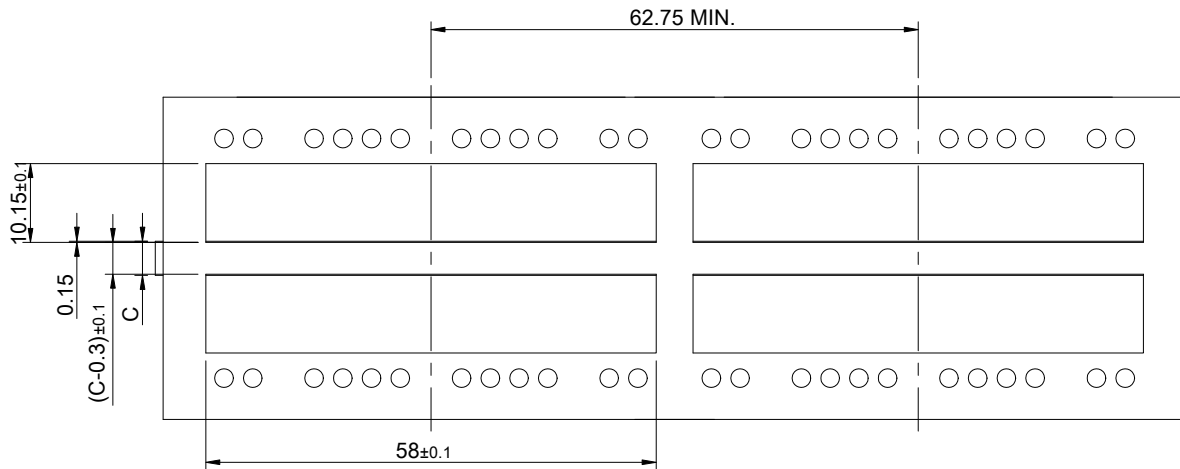
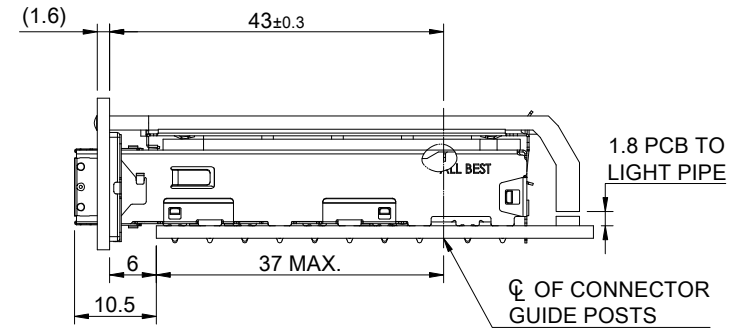

BELLY TO BELLY CONFIGURATION

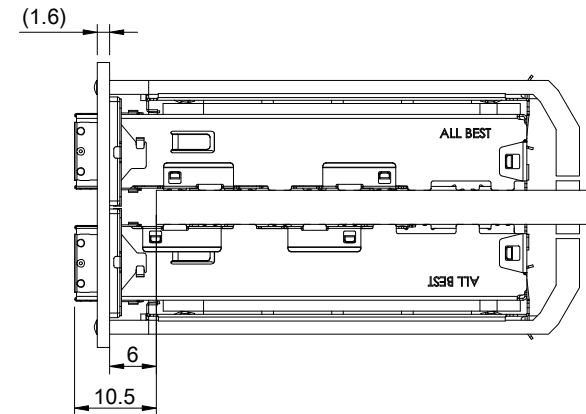

C = THICKNESS OF PC BOARD
 SINGLE-SIDE = 1.6MM (MIN.)
 BELLY TO BELLY = 4.4MM (MIN.)

THIS PRINT IS
PRELIMINARY
 UNQUALIFIED PRODUCT
 CONTACT PRODUCT ENGINEERING
 BEFORE USING THIS PRINT



TITLE: QSFP+ 1X3 Cage Assembly w/ Light Pipe & Heat Sink

DWG#: R-OR-Q3-4CGEG

SHEET: 2/4
 REV. REF

UNIT: mm
 SCALE: A4 1:1

FINISH: CHECKED:

THIRD ANGLE PROJECTION

MATERIAL: RoHS Compliant

APPROVED:

TOLERANCE: Angle: ± 1°
 X ± 0.15 .X ± 0.10 .XX ± 0.05

DRAWN: Gary

DATE: 03/15/2024

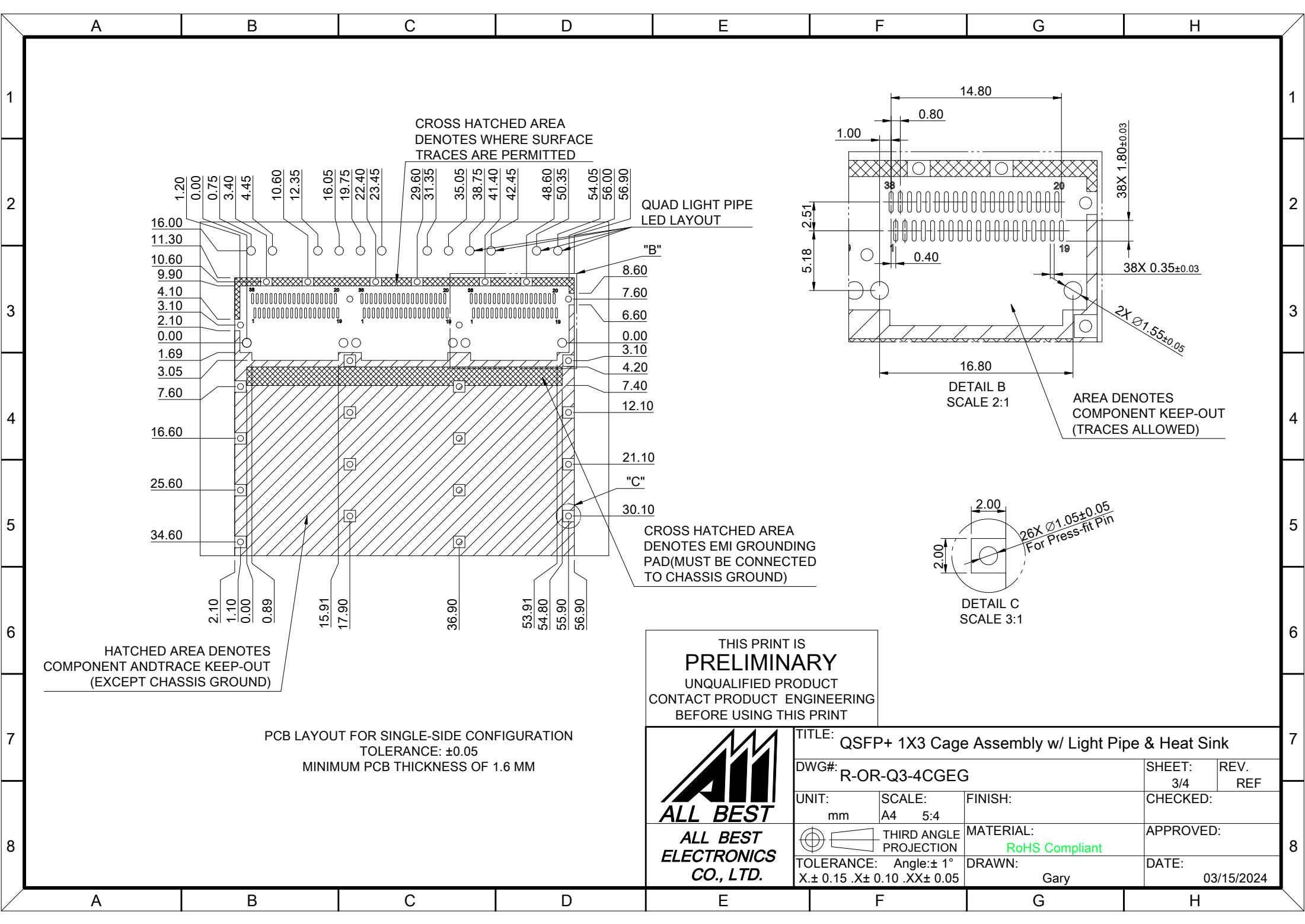

THIS PRINT IS
PRELIMINARY
UNQUALIFIED PRODUCT
CONTACT PRODUCT ENGINEERING
BEFORE USING THIS PRINT



TITLE: QSFP+ 1X3 Cage Assembly w/ Light Pipe & Heat Sink			
DWG#: R-OR-Q3-4CGEG		SHEET: 3/4	REV. REF
UNIT: mm	SCALE: A4 5:4	FINISH:	
THIRD ANGLE PROJECTION		MATERIAL: RoHS Compliant	
TOLERANCE: Angle: ± 1° X ± 0.15 .X ± 0.10 .XX ± 0.05		DRAWN: Gary	DATE: 03/15/2024
CHECKED:		APPROVED:	

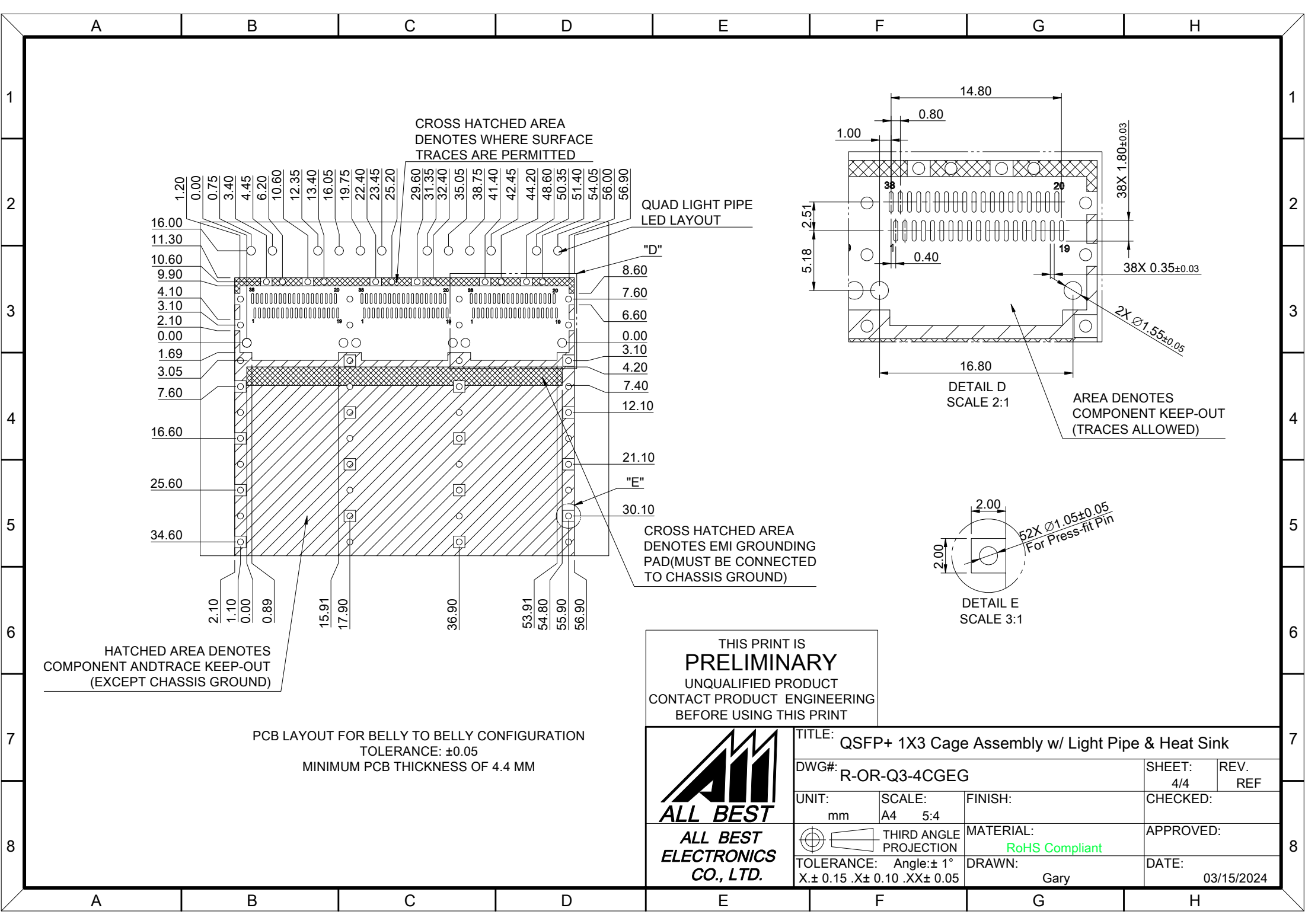

PCB LAYOUT FOR BELLY TO BELLY CONFIGURATION
 TOLERANCE: ± 0.05
 MINIMUM PCB THICKNESS OF 4.4 MM

THIS PRINT IS
PRELIMINARY
 UNQUALIFIED PRODUCT
 CONTACT PRODUCT ENGINEERING
 BEFORE USING THIS PRINT

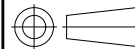
 ALL BEST ELECTRONICS CO., LTD.		TITLE: QSFP+ 1X3 Cage Assembly w/ Light Pipe & Heat Sink	
		DWG#: R-OR-Q3-4CGEG	SHEET: 4/4 REV. REF
UNIT: mm	SCALE: A4 5:4	FINISH:	CHECKED:
 THIRD ANGLE PROJECTION	MATERIAL: RoHS Compliant	APPROVED:	
TOLERANCE: Angle: $\pm 1^\circ$ $X \pm 0.15$.X ± 0.10 .XX ± 0.05	DRAWN: Gary	DATE: 03/15/2024	