

DETAIL A  
SCALE 5:1

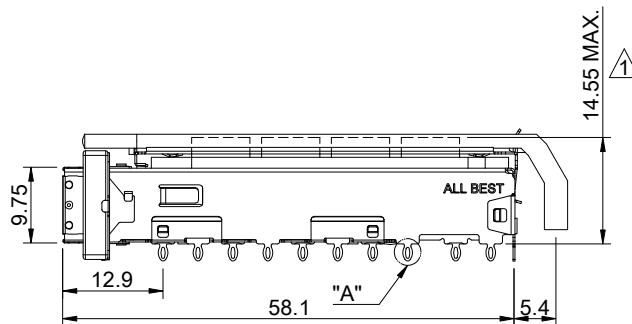
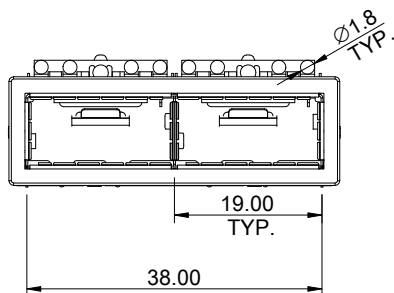
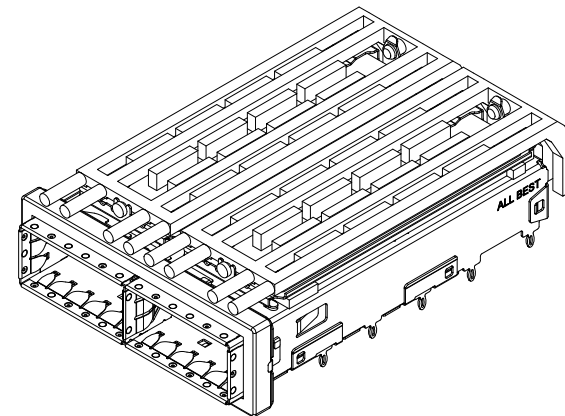

MATERIAL  
 CAGE: NICKEL SILVER  
 HEAT SINK: ALUMINUM  
 HEAT SINK CLIP: STAINLESS STEEL  
 EMI SPRING: STAINLESS STEEL  
 EMI GASKET FLANGE: STAINLESS STEEL  
 EMI GASKET: CONDUCTIVE ELASTOMER  
 LIGHT PIPE: PC

FINISH  
 HEAT SINK: ANODE PROCESS

NOTE  
 ▲ DIMENSION APPLIES WITH MODULE INSERTED IN CAGE

THIS PRINT IS  
**PRELIMINARY**  
 UNQUALIFIED PRODUCT  
 CONTACT PRODUCT ENGINEERING  
 BEFORE USING THIS PRINT



TITLE: QSFP+ 1X2 Cage Assembly w/ Light Pipe & Heat Sink

DWG#: R-OR-Q2-4CGEG

SHEET: 1/4  
 REV. REF

UNIT: mm  
 SCALE: A4 1:1

FINISH: CHECKED:

THIRD ANGLE PROJECTION

MATERIAL: RoHS Compliant

APPROVED:

TOLERANCE: Angle: ± 1°  
 X: ± 0.25 .X: ± 0.20 .XX: ± 0.15

DRAWN: Gary

DATE: 03/15/2024

A B C D E F G H

1  
2  
3  
4  
5  
6  
7  
8

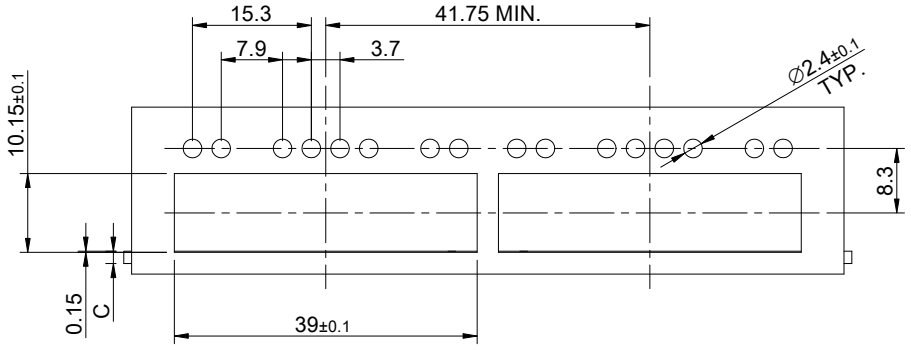

SINGLE-SIDE CONFIGURATION

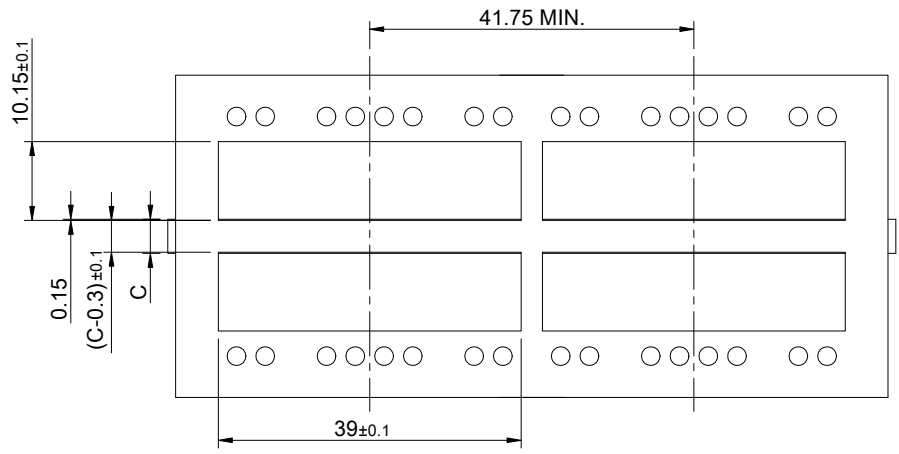
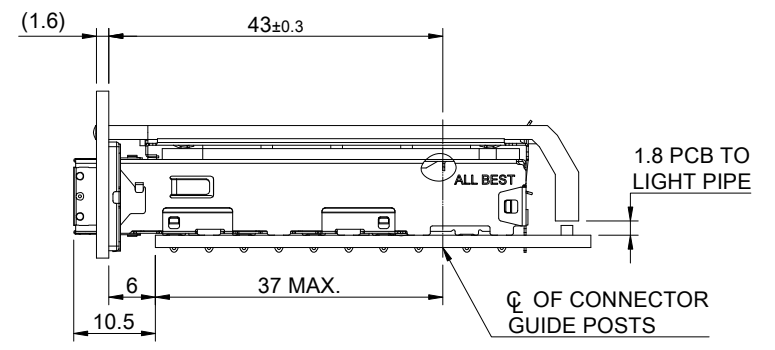

BELLY TO BELLY CONFIGURATION

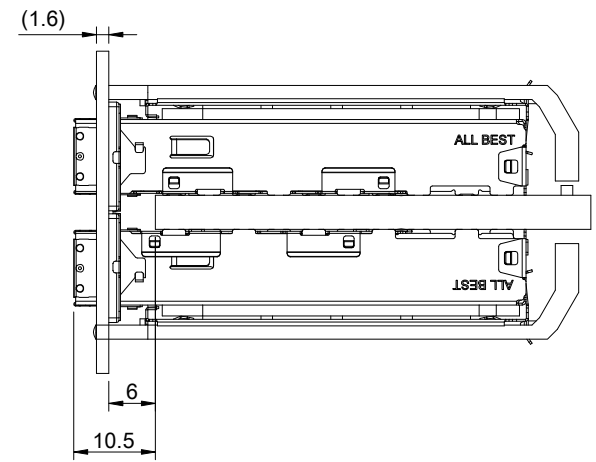

C = THICKNESS OF PC BOARD  
 SINGLE-SIDE = 1.6MM (MIN.)  
 BELLY TO BELLY = 4.4MM (MIN.)

THIS PRINT IS  
**PRELIMINARY**  
 UNQUALIFIED PRODUCT  
 CONTACT PRODUCT ENGINEERING  
 BEFORE USING THIS PRINT



TITLE: QSFP+ 1X2 Cage Assembly w/ Light Pipe & Heat Sink			
DWG#: R-OR-Q2-4CGEG		SHEET: 2/4	REV. REF
UNIT: mm	SCALE: A4 1:1	CHECKED:	
THIRD ANGLE PROJECTION		APPROVED:	
TOLERANCE: Angle: ± 1°		DATE: 03/15/2024	
X.± 0.15 .X± 0.10 .XX± 0.05		DRAWN: Gary	
		MATERIAL: RoHS Compliant	

A B C D E F G H

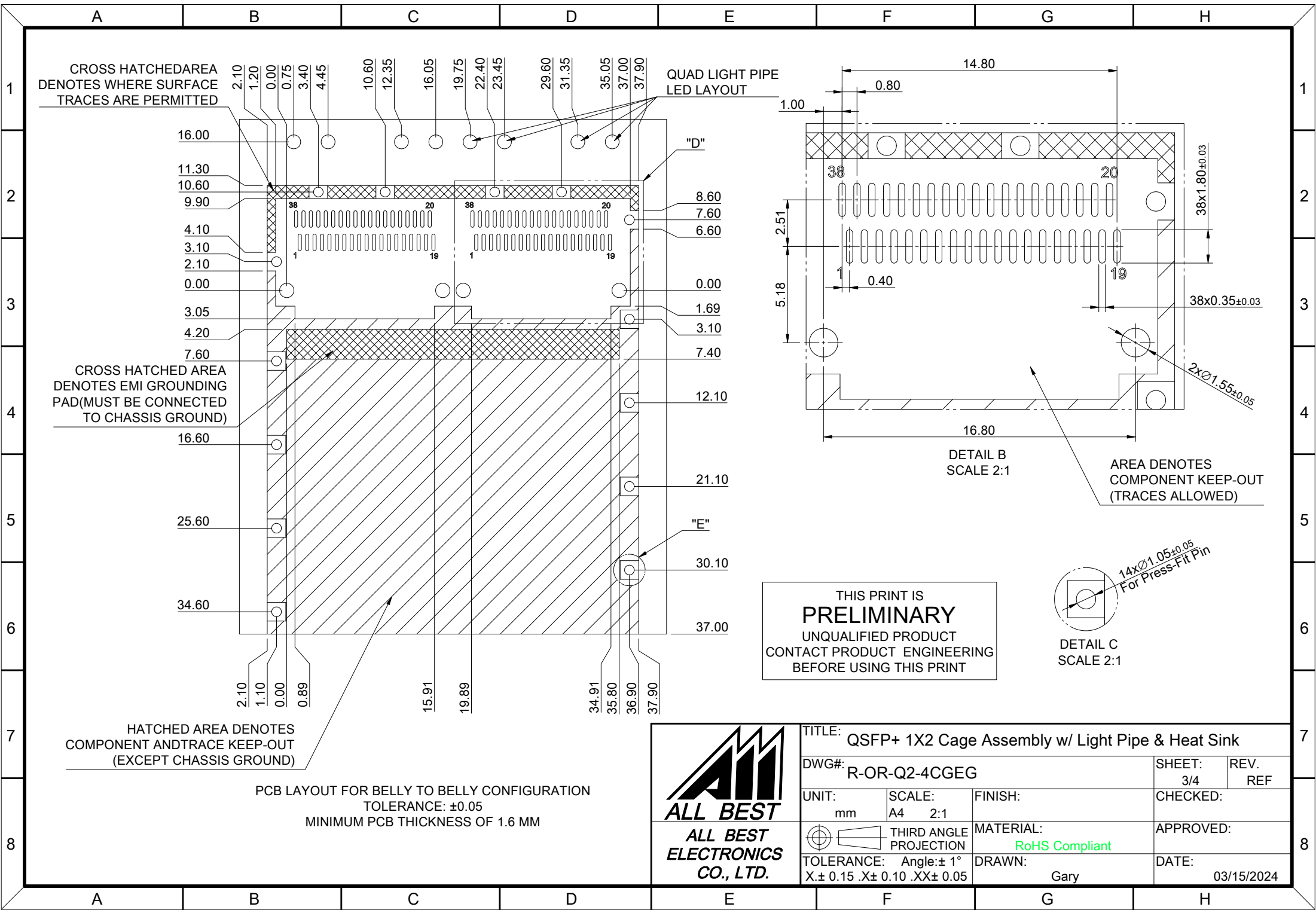

CROSS HATCHED AREA DENOTES WHERE SURFACE TRACES ARE PERMITTED

CROSS HATCHED AREA DENOTES EMI GROUNDING PAD (MUST BE CONNECTED TO CHASSIS GROUND)

HATCHED AREA DENOTES COMPONENT AND TRACE KEEP-OUT (EXCEPT CHASSIS GROUND)

QUAD LIGHT PIPE LED LAYOUT

THIS PRINT IS  
**PRELIMINARY**  
UNQUALIFIED PRODUCT  
CONTACT PRODUCT ENGINEERING  
BEFORE USING THIS PRINT

AREA DENOTES COMPONENT KEEP-OUT (TRACES ALLOWED)

PCB LAYOUT FOR BELLY TO BELLY CONFIGURATION  
TOLERANCE: ±0.05  
MINIMUM PCB THICKNESS OF 1.6 MM

DETAIL C  
SCALE 2:1



TITLE: QSFP+ 1X2 Cage Assembly w/ Light Pipe & Heat Sink			
DWG#: R-OR-Q2-4CGEG		SHEET: 3/4	REV. REF
UNIT: mm	SCALE: A4 2:1	CHECKED:	
TOLERANCE: Angle: ± 1° X ± 0.15 .X ± 0.10 .XX ± 0.05		MATERIAL: RoHS Compliant	APPROVED:
THIRD ANGLE PROJECTION		DRAWN: Gary	DATE: 03/15/2024

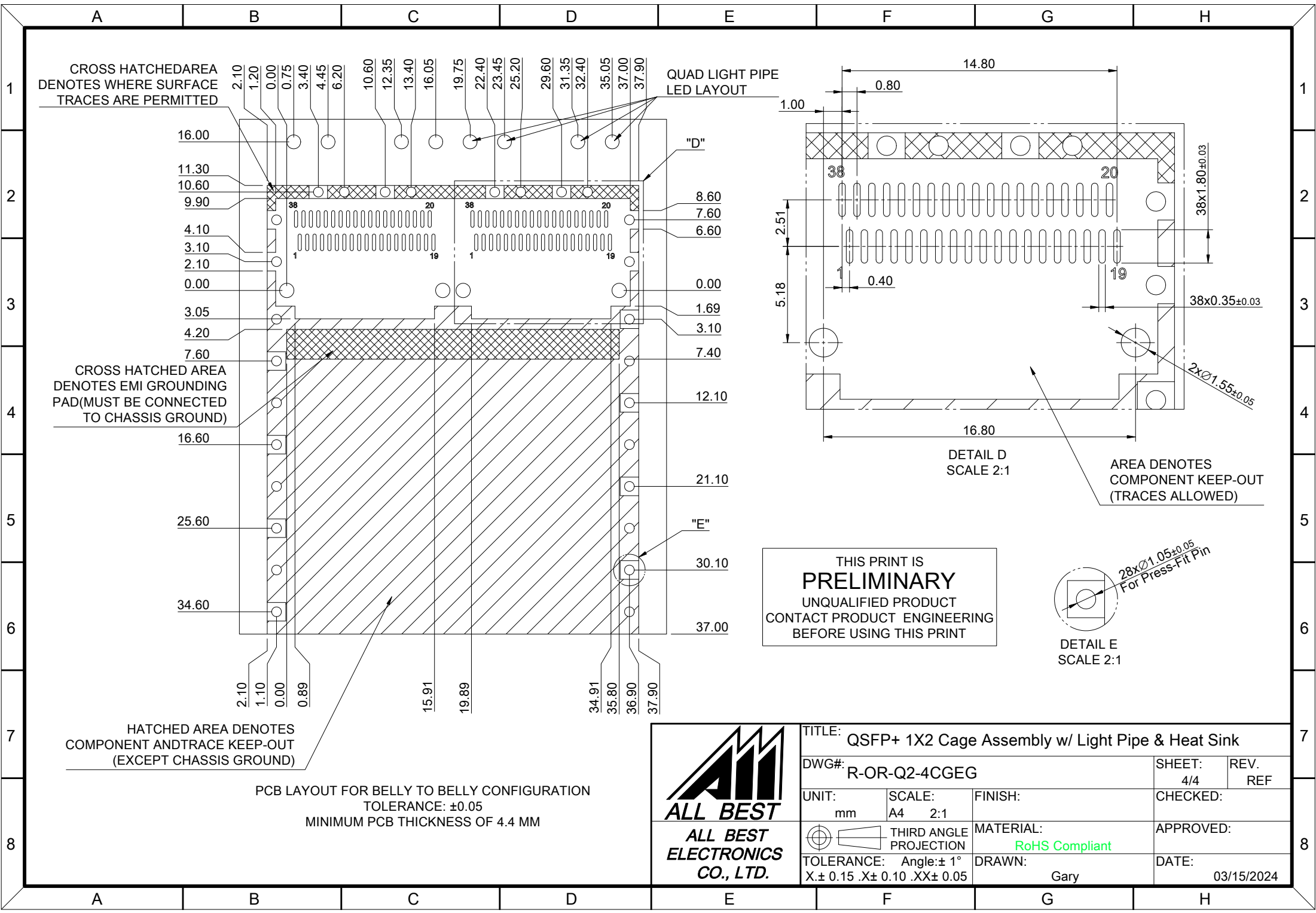

TITLE: QSFP+ 1X2 Cage Assembly w/ Light Pipe & Heat Sink			
DWG#: R-OR-Q2-4CGEG		SHEET: 4/4	REV. REF
UNIT: mm	SCALE: A4 2:1	CHECKED:	
TOLERANCE: Angle: ± 1° X ± 0.15 .X ± 0.10 .XX ± 0.05		MATERIAL: RoHS Compliant	APPROVED:
DRAWN: Gary		DATE: 03/15/2024	