

DETAIL A
SCALE 5:1

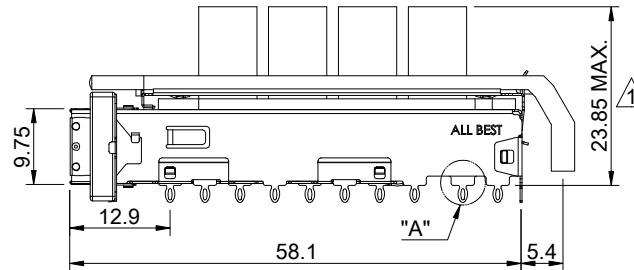
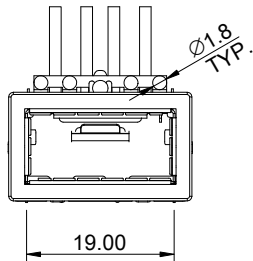
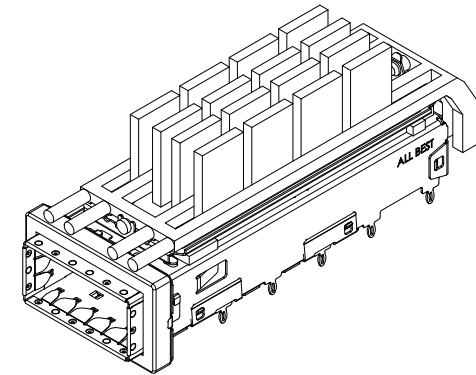

MATERIAL
 CAGE: NICKEL SILVER
 HEAT SINK: ALUMINUM
 HEAT SINK CLIP: STAINLESS STEEL
 EMI SPRING: STAINLESS STEEL
 EMI GASKET FLANGE: STAINLESS STEEL
 EMI GASKET: CONDUCTIVE ELASTOMER
 LIGHT PIPE: PC

FINISH
 HEAT SINK: ANODE PROCESS

NOTE
 ▲ DIMENSION APPLIES WITH MODULE INSERTED IN CAGE

THIS PRINT IS
PRELIMINARY
 UNQUALIFIED PRODUCT
 CONTACT PRODUCT ENGINEERING
 BEFORE USING THIS PRINT



TITLE: QSFP+ 1X1 Cage Assembly w/ Light Pipe & Heat Sink			
DWG#: R-OR-Q1-4CGEE		SHEET: 1/4	REV. REF
UNIT: mm	SCALE: A4 1:1	CHECKED:	
THIRD ANGLE PROJECTION		APPROVED:	
TOLERANCE: Angle: ± 1°		MATERIAL: RoHS Compliant	DATE: 03/15/2024
X.± 0.25 .X± 0.20 .XX± 0.15		DRAWN: Gary	

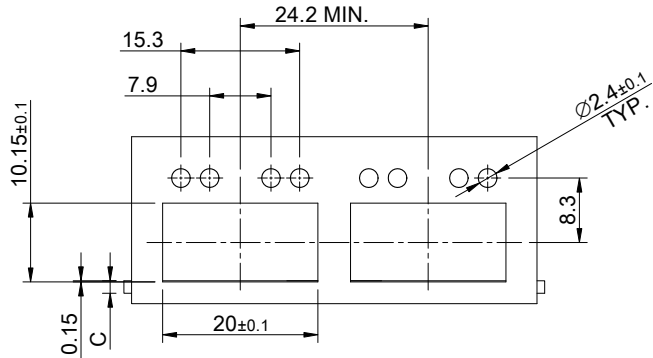

SINGLE-SIDE CONFIGURATION

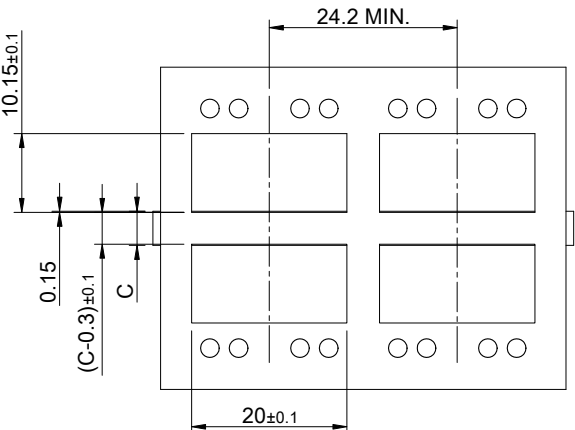
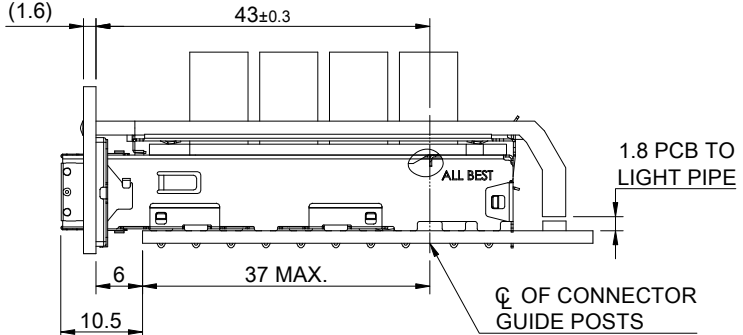

BELLY TO BELLY CONFIGURATION

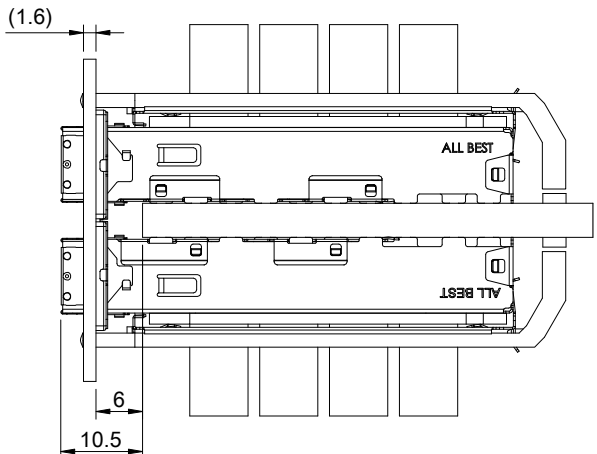

C = THICKNESS OF PC BOARD
 SINGLE-SIDE = 1.6MM (MIN.)
 BELLY TO BELLY = 4.4MM (MIN.)

THIS PRINT IS
PRELIMINARY
 UNQUALIFIED PRODUCT
 CONTACT PRODUCT ENGINEERING
 BEFORE USING THIS PRINT



TITLE: QSFP+ 1X1 Cage Assembly w/ Light Pipe & Heat Sink			
DWG#: R-OR-Q1-4CGEE		SHEET: 2/4	REV. REF
UNIT: mm	SCALE: A4 1:1	CHECKED:	
THIRD ANGLE PROJECTION		MATERIAL: RoHS Compliant	APPROVED:
TOLERANCE: Angle: ± 1° X ± 0.15 .X ± 0.10 .XX ± 0.05		DRAWN: Gary	DATE: 03/15/2024

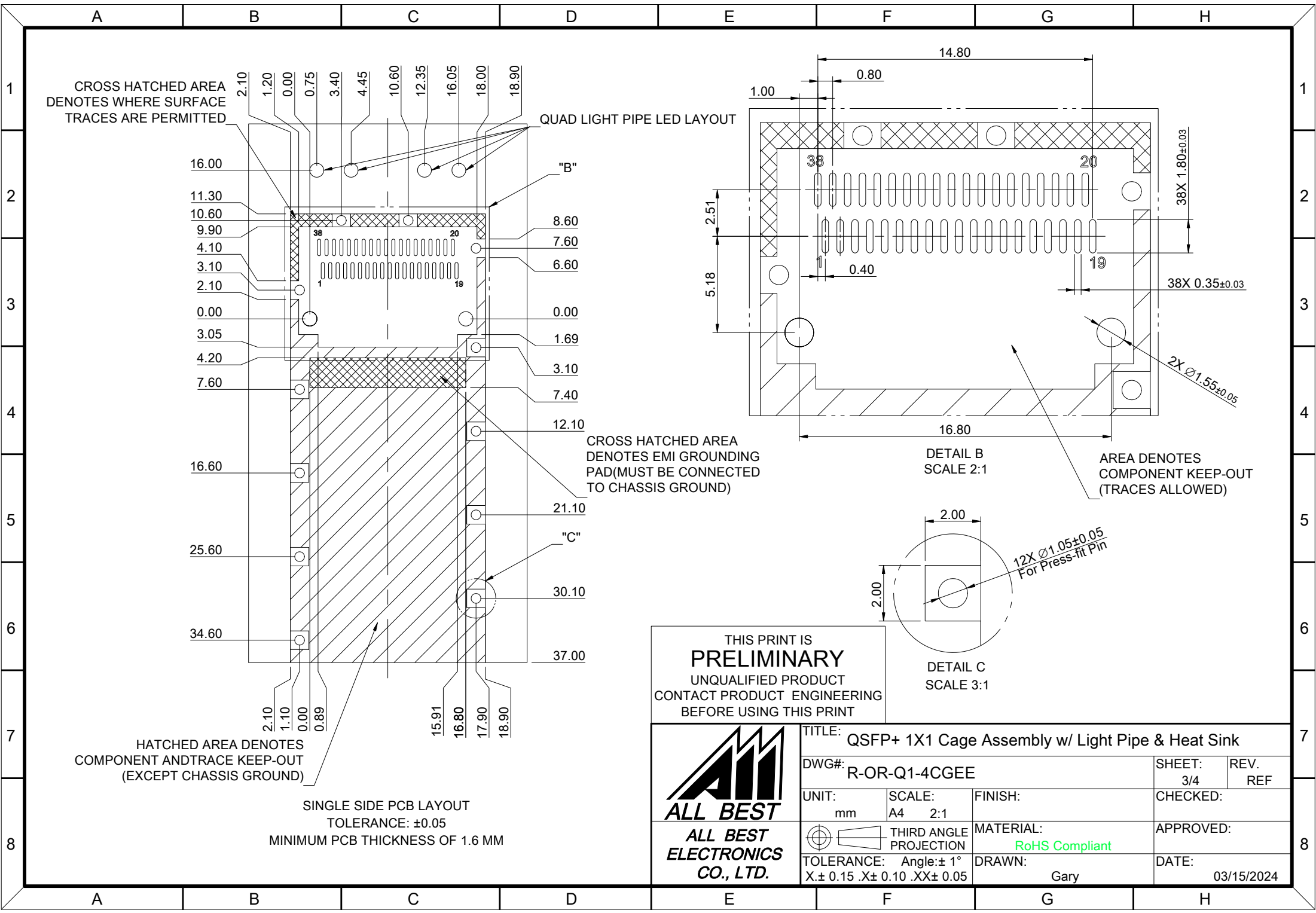

THIS PRINT IS
PRELIMINARY
UNQUALIFIED PRODUCT
CONTACT PRODUCT ENGINEERING
BEFORE USING THIS PRINT



TITLE: QSFP+ 1X1 Cage Assembly w/ Light Pipe & Heat Sink			
DWG#: R-OR-Q1-4CGEE		SHEET: 3/4	REV. REF
UNIT: mm	SCALE: A4 2:1	FINISH:	CHECKED:
THIRD ANGLE PROJECTION		MATERIAL: RoHS Compliant	APPROVED:
TOLERANCE: Angle: $\pm 1^\circ$ X: ± 0.15 .X: ± 0.10 .XX: ± 0.05		DRAWN: Gary	DATE: 03/15/2024

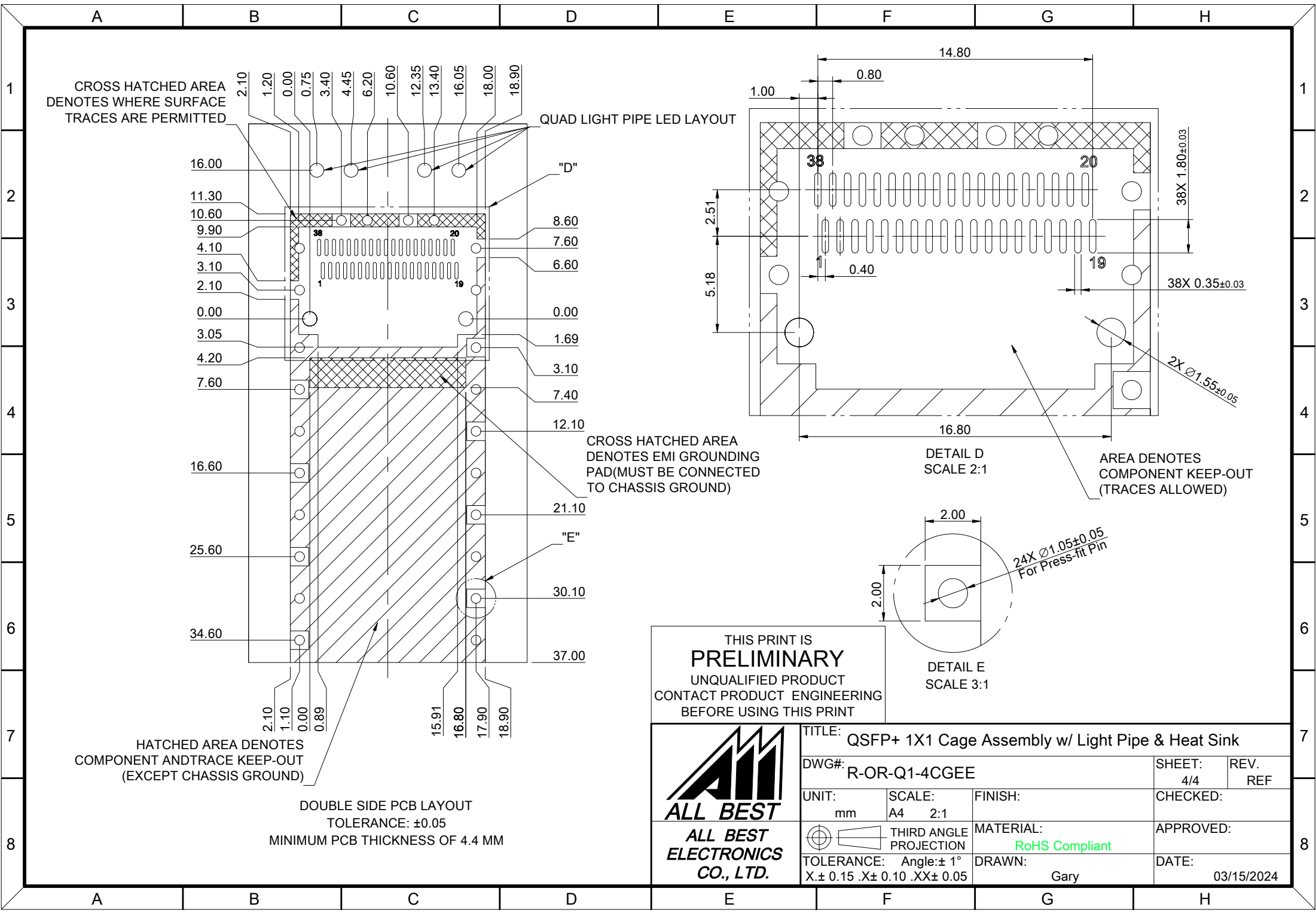

CROSS HATCHED AREA DENOTES WHERE SURFACE TRACES ARE PERMITTED

QUAD LIGHT PIPE LED LAYOUT

CROSS HATCHED AREA DENOTES EMI GROUNDING PAD (MUST BE CONNECTED TO CHASSIS GROUND)

HATCHED AREA DENOTES COMPONENT AND TRACE KEEP-OUT (EXCEPT CHASSIS GROUND)

DOUBLE SIDE PCB LAYOUT
TOLERANCE: ±0.05
MINIMUM PCB THICKNESS OF 4.4 MM

THIS PRINT IS
PRELIMINARY
UNQUALIFIED PRODUCT
CONTACT PRODUCT ENGINEERING
BEFORE USING THIS PRINT

DETAIL D
SCALE 2:1

AREA DENOTES
COMPONENT KEEP-OUT
(TRACES ALLOWED)

DETAIL E
SCALE 3:1



TITLE: QSFP+ 1X1 Cage Assembly w/ Light Pipe & Heat Sink

DWG#: R-OR-Q1-4CGEE

SHEET: 4/4
REV. REF

UNIT: mm
SCALE: A4 2:1

FINISH: MATERIAL: RoHS Compliant

CHECKED: APPROVED:

TOLERANCE: X±0.15 .XX±0.10 .XX±0.05
THIRD ANGLE PROJECTION
Angle: ±1°

DRAWN: Gary

DATE: 03/15/2024