

DETAIL A
SCALE 5:1

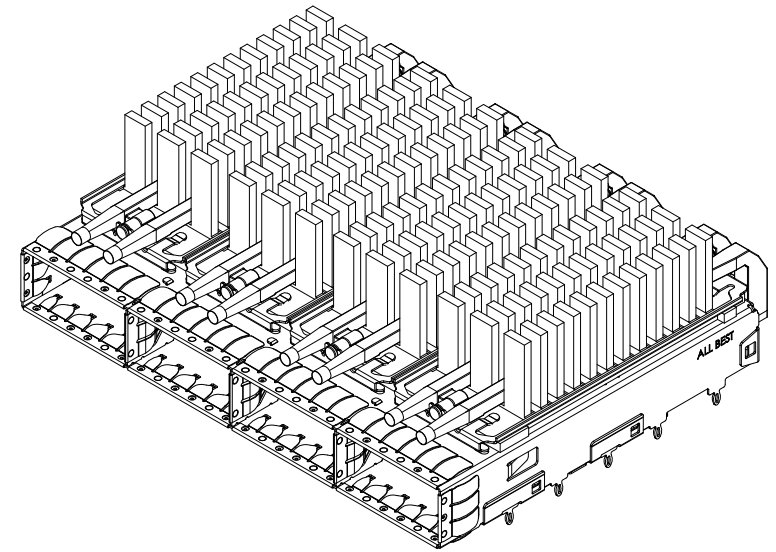

MATERIAL
 CAGE: NICKLE SILVER
 HEAT SINK: ALUMINUM
 HEAT SINK CLIP: STAINLESS STEEL
 EMI SPRING: STAINLESS STEEL
 LIGHT PIPE: PC

FINISH
 HEAT SINK: ANODE PROCESS

NOTE
 ▲ DIMENSION APPLIES WITH MODULE INSERTED IN CAGE

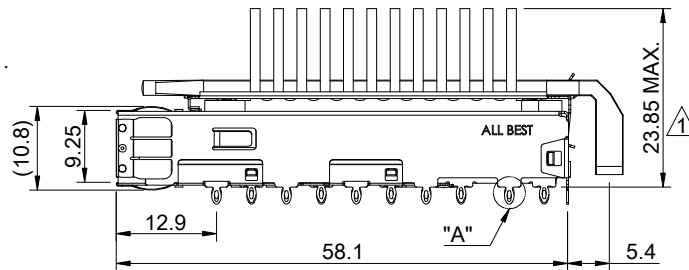
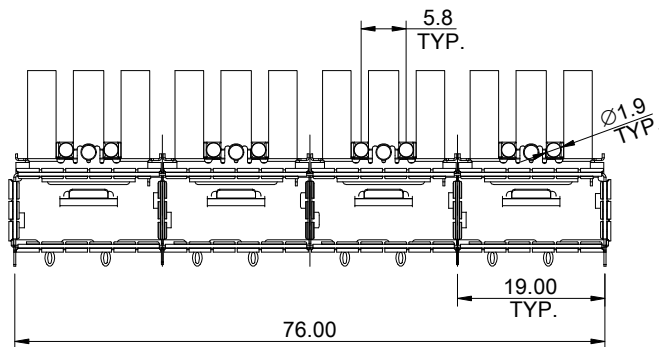

THIS PRINT IS
PRELIMINARY
 UNQUALIFIED PRODUCT
 CONTACT PRODUCT ENGINEERING
 BEFORE USING THIS PRINT



TITLE: QSFP+ 1X4 Cage Assembly w/ Light Pipe & Heat Sink

DWG#: R-OR-Q4-4CME3

SHEET: 1/4
 REV. REF

UNIT: mm
 SCALE: A4 1:1

FINISH: CHECKED:

THIRD ANGLE PROJECTION

MATERIAL: RoHS Compliant
 APPROVED:

TOLERANCE: Angle: ± 1°
 X: ± 0.25 .X: ± 0.20 .XX: ± 0.15

DRAWN: Gary
 DATE: 03/15/2024

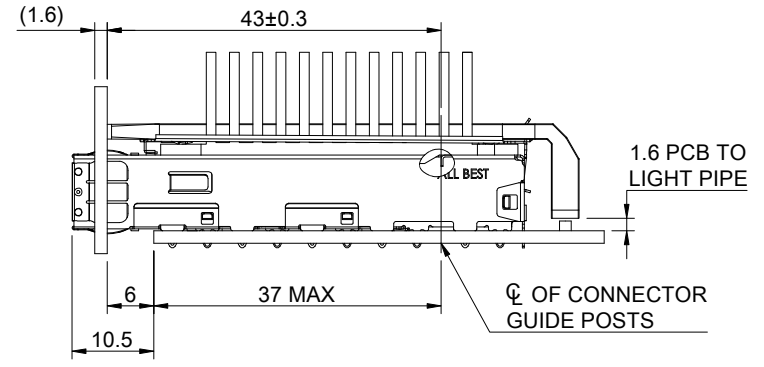
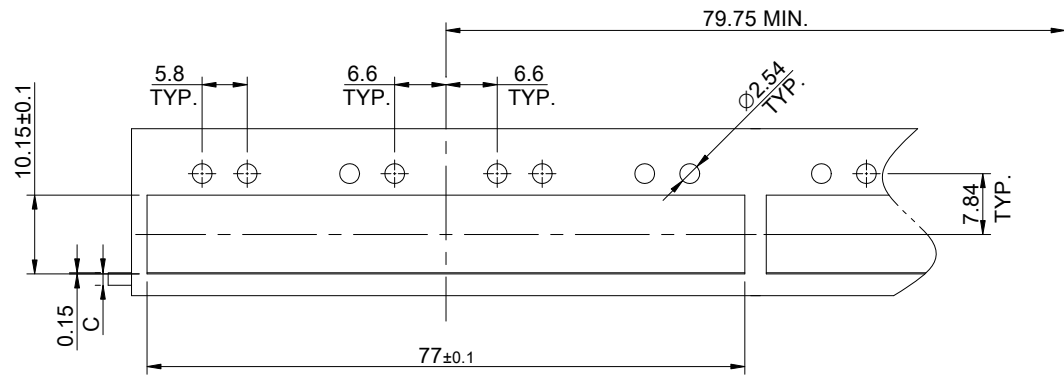

SINGLE-SIDE CONFIGURATION

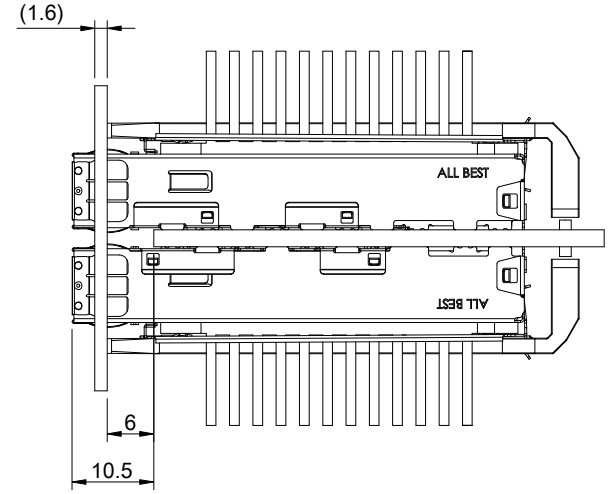
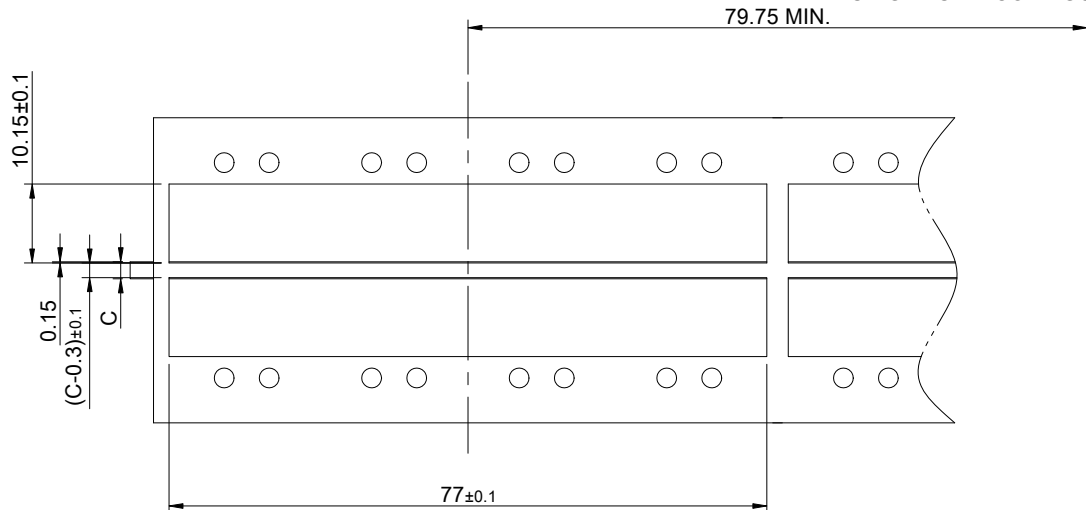

BELLY TO BELLY CONFIGURATION

C = THICKNESS OF PC BOARD
 SINGLE-SIDE = 1.6MM (MIN.)
 BELLY TO BELLY = 2.2MM (MIN.)

THIS PRINT IS
PRELIMINARY
 UNQUALIFIED PRODUCT
 CONTACT PRODUCT ENGINEERING
 BEFORE USING THIS PRINT



TITLE: QSFP+ 1X4 Cage Assembly w/ Light Pipe & Heat Sink			
DWG#: R-OR-Q4-4CME3		SHEET: 2/4	REV. REF
UNIT: mm	SCALE: A4 1:1	CHECKED:	
THIRD ANGLE PROJECTION		APPROVED:	
TOLERANCE: Angle: ± 1°		DATE: 03/15/2024	
X ± 0.15 .X ± 0.10 .XX ± 0.05		DRAWN: Gary	

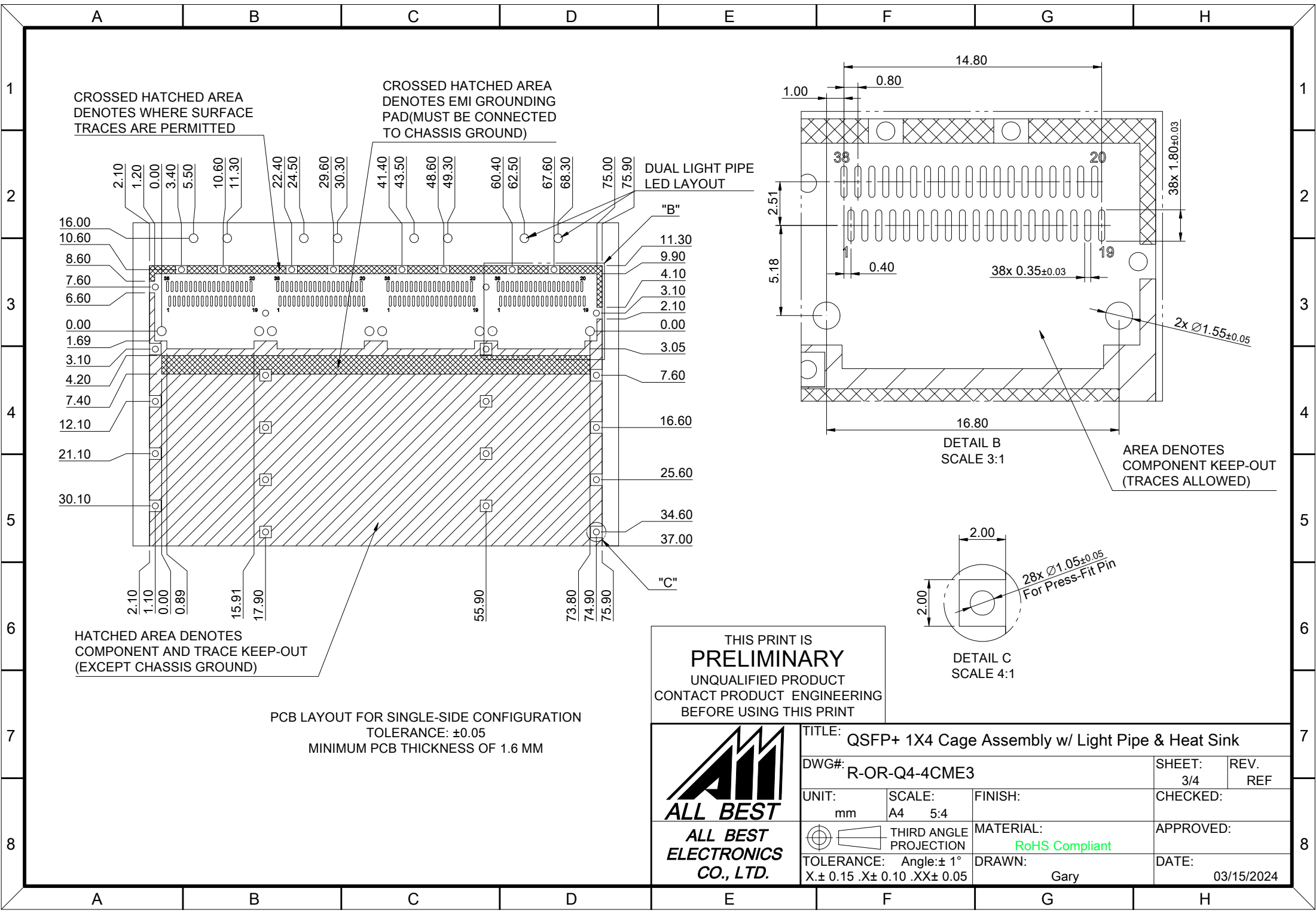

CROSSED HATCHED AREA DENOTES WHERE SURFACE TRACES ARE PERMITTED

CROSSED HATCHED AREA DENOTES EMI GROUNDING PAD (MUST BE CONNECTED TO CHASSIS GROUND)

DUAL LIGHT PIPE LED LAYOUT

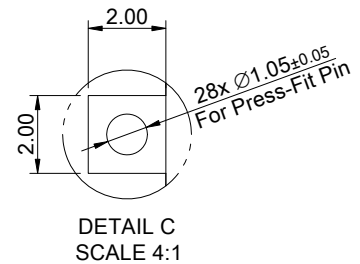
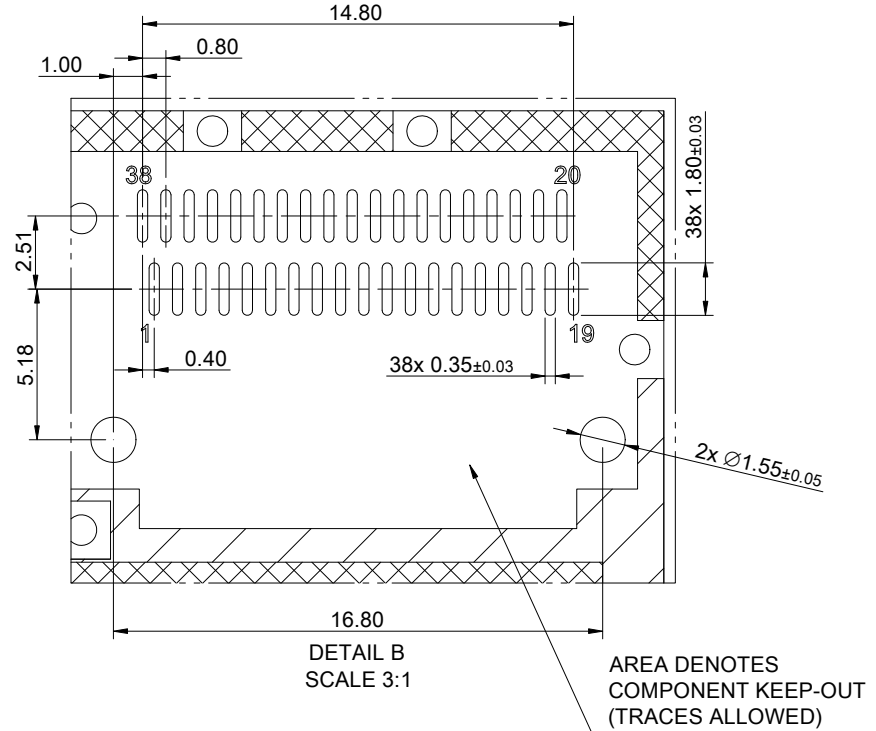

HATCHED AREA DENOTES COMPONENT AND TRACE KEEP-OUT (EXCEPT CHASSIS GROUND)

PCB LAYOUT FOR SINGLE-SIDE CONFIGURATION
TOLERANCE: ±0.05
MINIMUM PCB THICKNESS OF 1.6 MM

THIS PRINT IS
PRELIMINARY
UNQUALIFIED PRODUCT
CONTACT PRODUCT ENGINEERING
BEFORE USING THIS PRINT

	TITLE: QSFP+ 1X4 Cage Assembly w/ Light Pipe & Heat Sink		
	DWG#: R-OR-Q4-4CME3		SHEET: 3/4
	UNIT: mm	SCALE: A4 5:4	REV. REF
	FINISH:		CHECKED:
THIRD ANGLE PROJECTION		MATERIAL: RoHS Compliant	APPROVED:
TOLERANCE: Angle: ± 1° X ± 0.15 .X ± 0.10 .XX ± 0.05		DRAWN: Gary	DATE: 03/15/2024

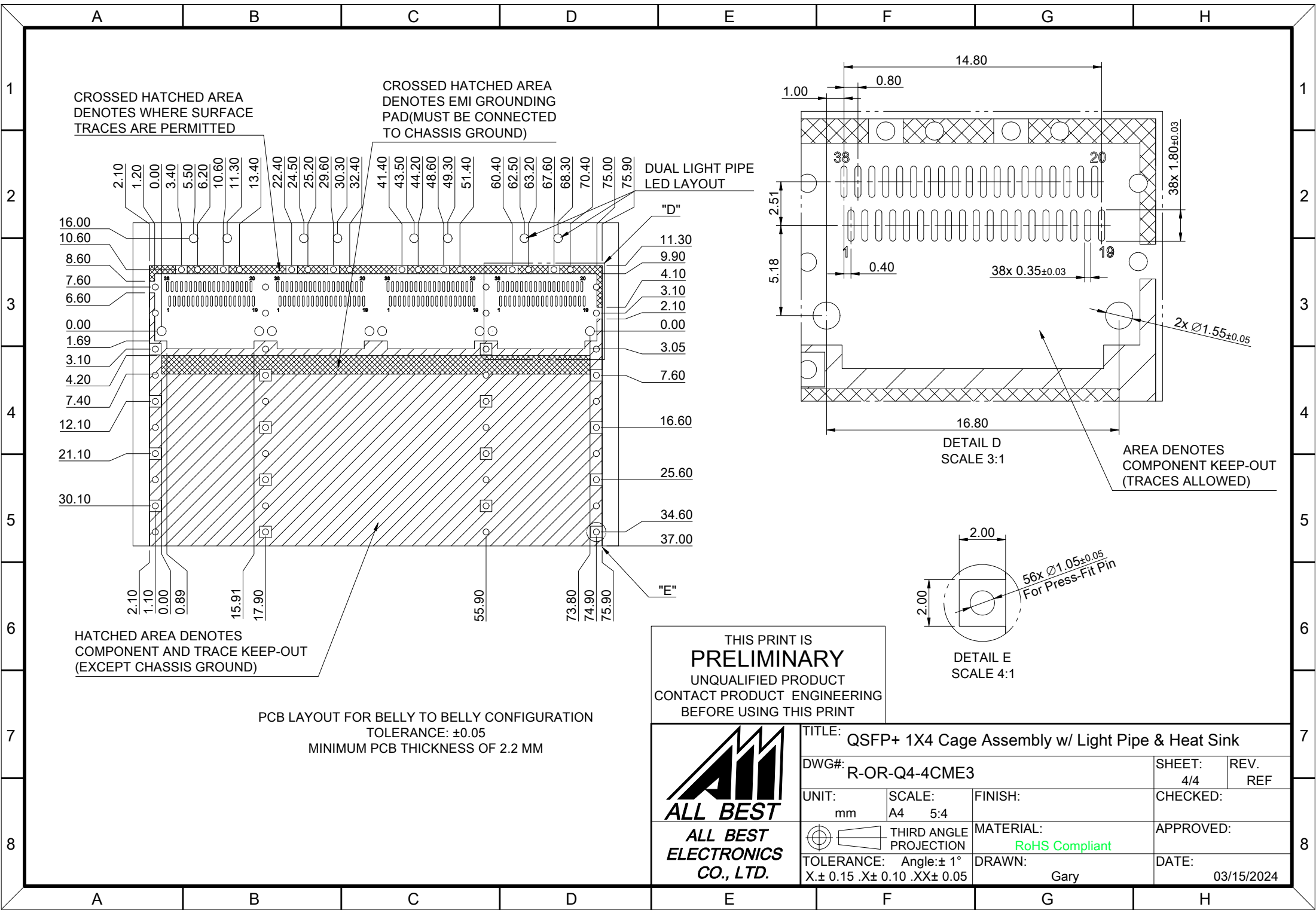

CROSSED HATCHED AREA DENOTES WHERE SURFACE TRACES ARE PERMITTED

CROSSED HATCHED AREA DENOTES EMI GROUNDING PAD (MUST BE CONNECTED TO CHASSIS GROUND)

DUAL LIGHT PIPE LED LAYOUT

HATCHED AREA DENOTES COMPONENT AND TRACE KEEP-OUT (EXCEPT CHASSIS GROUND)

AREA DENOTES COMPONENT KEEP-OUT (TRACES ALLOWED)

PCB LAYOUT FOR BELLY TO BELLY CONFIGURATION
TOLERANCE: ±0.05
MINIMUM PCB THICKNESS OF 2.2 MM

THIS PRINT IS
PRELIMINARY
UNQUALIFIED PRODUCT
CONTACT PRODUCT ENGINEERING
BEFORE USING THIS PRINT



TITLE: QSFP+ 1X4 Cage Assembly w/ Light Pipe & Heat Sink			
DWG#: R-OR-Q4-4CME3		SHEET: 4/4	REV. REF
UNIT: mm	SCALE: A4 5:4	FINISH:	CHECKED:
TOLERANCE: Angle: ±1° X ± 0.15 .X ± 0.10 .XX ± 0.05		MATERIAL: RoHS Compliant	APPROVED:
THIRD ANGLE PROJECTION		DRAWN: Gary	DATE: 03/15/2024