

DETAIL A
SCALE 5:1

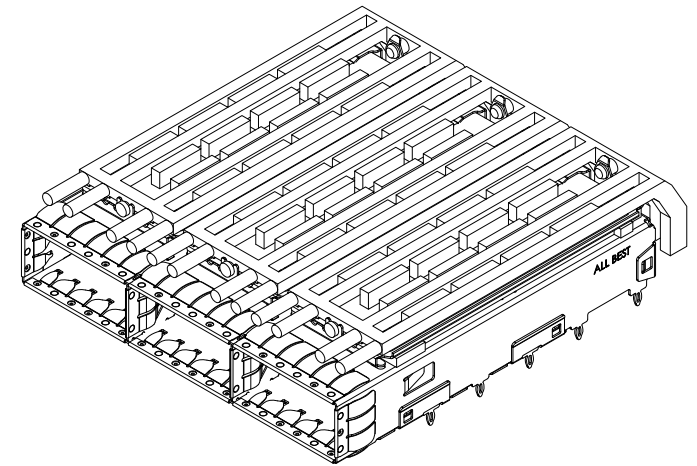

MATERIAL
 CAGE: NICKEL SILVER
 HEAT SINK: ALUMINUM
 HEAT SINK CLIP: STAINLESS STEEL
 EMI SPRING: STAINLESS STEEL
 LIGHT PIPE: PC

FINISH
 HEAT SINK: ANODE PROCESS

NOTE
 ▲ DIMENSION APPLIES WITH MODULE INSERTED IN CAGE

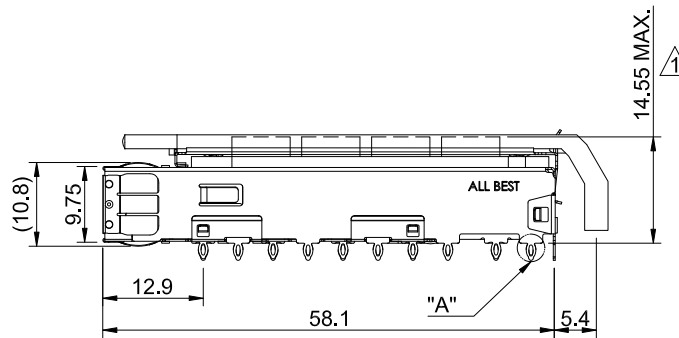
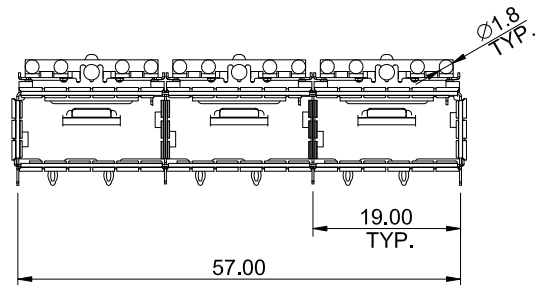

TITLE: QSFP+ 1X2 Cage Assembly w/ Light Pipe & Heat Sink

DWG#: R-OR-Q3-4CMEG

UNIT: mm SCALE: A4 1:1

THIRD ANGLE PROJECTION

TOLERANCE: Angle: ± 1°
 X.± 0.25 .X± 0.20 .XX± 0.15

FINISH: MATERIAL: RoHS Compliant

DRAWN: Boris

SHEET: 1/4 REV. B

CHECKED: Gary Kang

APPROVED: George Yang

DATE: 01/22/2018

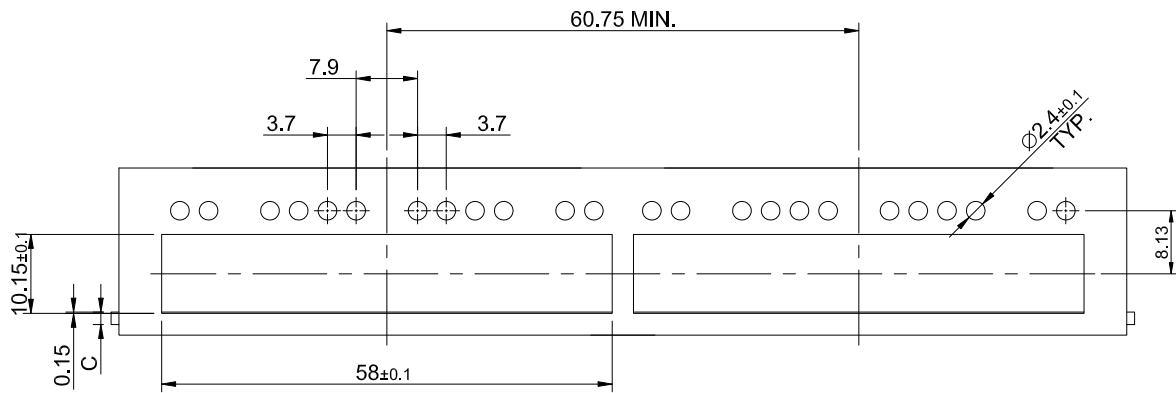

SINGLE-SIDE CONFIGURATION

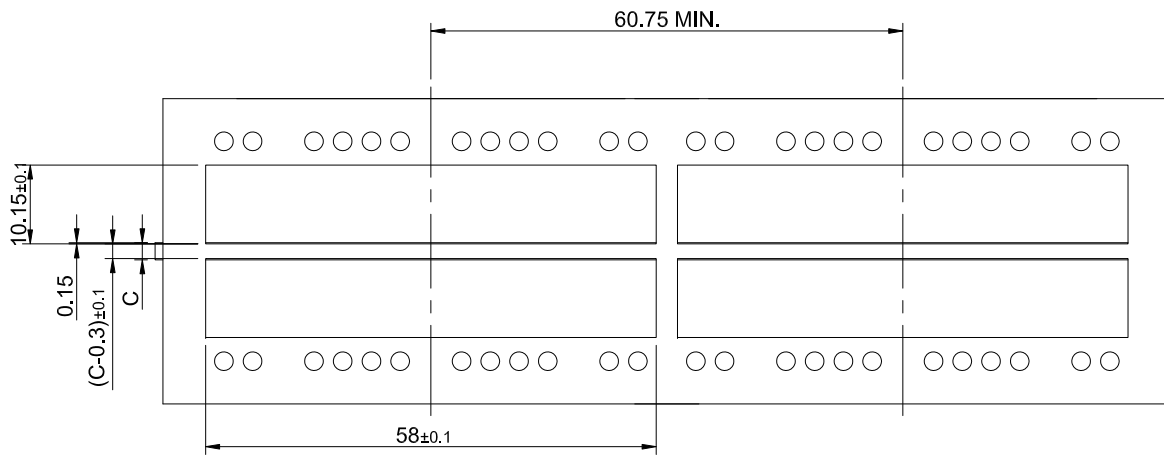
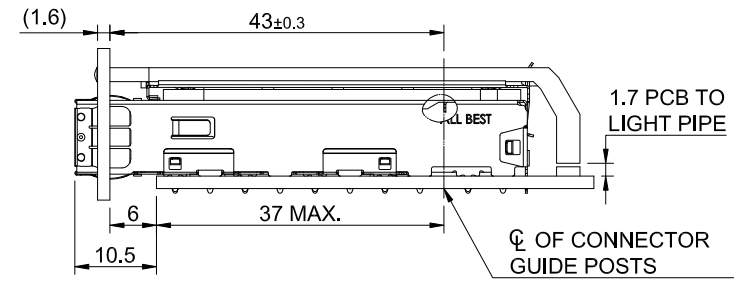

BELLY TO BELLY CONFIGURATION

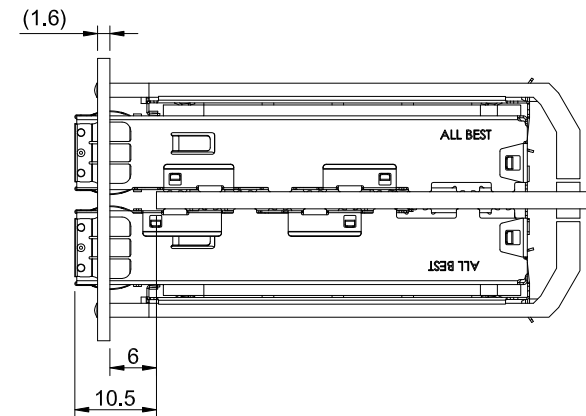

C = THICKNESS OF PC BOARD
 SINGLE-SIDE = 1.6MM (MIN.)
 BELLY TO BELLY = 2.2MM (MIN.)



TITLE: QSFP+ 1X3 Cage Assembly w/ Light Pipe & Heat Sink

DWG#: R-OR-Q3-4CMEG

SHEET: 2/4
 REV. B

UNIT: mm
 SCALE: A4 1:1

FINISH:

CHECKED: Gary Kang

THIRD ANGLE PROJECTION

MATERIAL: RoHS Compliant

APPROVED: George Yang

TOLERANCE: Angle: ± 1°
 X.± 0.15 .XX± 0.10 .XXX± 0.05

DRAWN: Boris

DATE: 01/22/2018

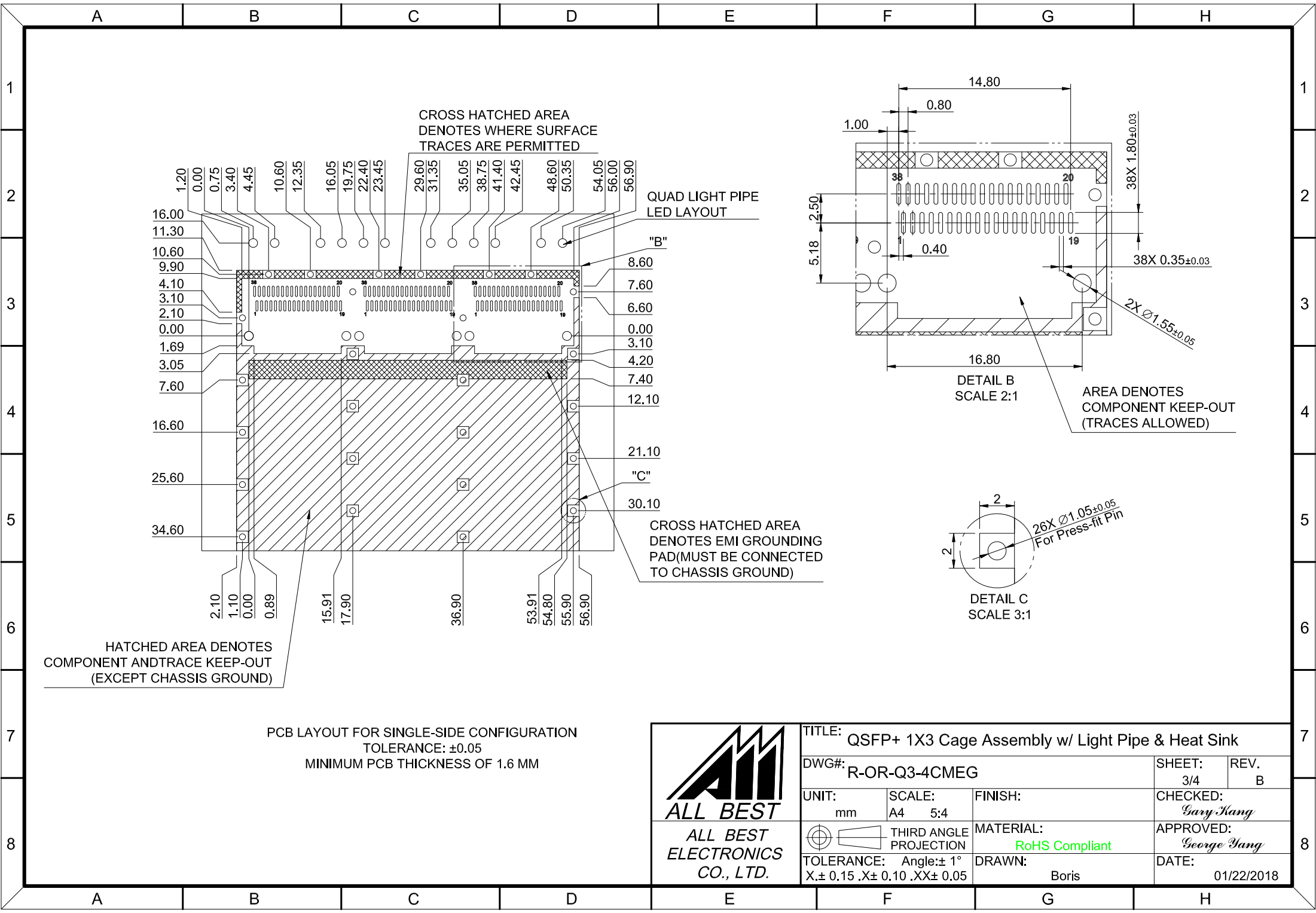

CROSS HATCHED AREA
DENOTES WHERE SURFACE
TRACES ARE PERMITTED

QUAD LIGHT PIPE
LED LAYOUT

CROSS HATCHED AREA
DENOTES EMI GROUNDING
PAD(MUST BE CONNECTED
TO CHASSIS GROUND)

HATCHED AREA DENOTES
COMPONENT AND TRACE KEEP-OUT
(EXCEPT CHASSIS GROUND)

AREA DENOTES
COMPONENT KEEP-OUT
(TRACES ALLOWED)

DETAIL C
SCALE 3:1

PCB LAYOUT FOR SINGLE-SIDE CONFIGURATION
TOLERANCE: ±0.05
MINIMUM PCB THICKNESS OF 1.6 MM



TITLE: QSFP+ 1X3 Cage Assembly w/ Light Pipe & Heat Sink			
DWG#: R-OR-Q3-4CMEG		SHEET: 3/4	REV. B
UNIT: mm	SCALE: A4 5:4	FINISH:	CHECKED: Gary Kang
THIRD ANGLE PROJECTION		MATERIAL: RoHS Compliant	APPROVED: George Yang
TOLERANCE: Angle: ± 1° X ± 0.15 .X ± 0.10 .XX ± 0.05		DRAWN: Boris	DATE: 01/22/2018

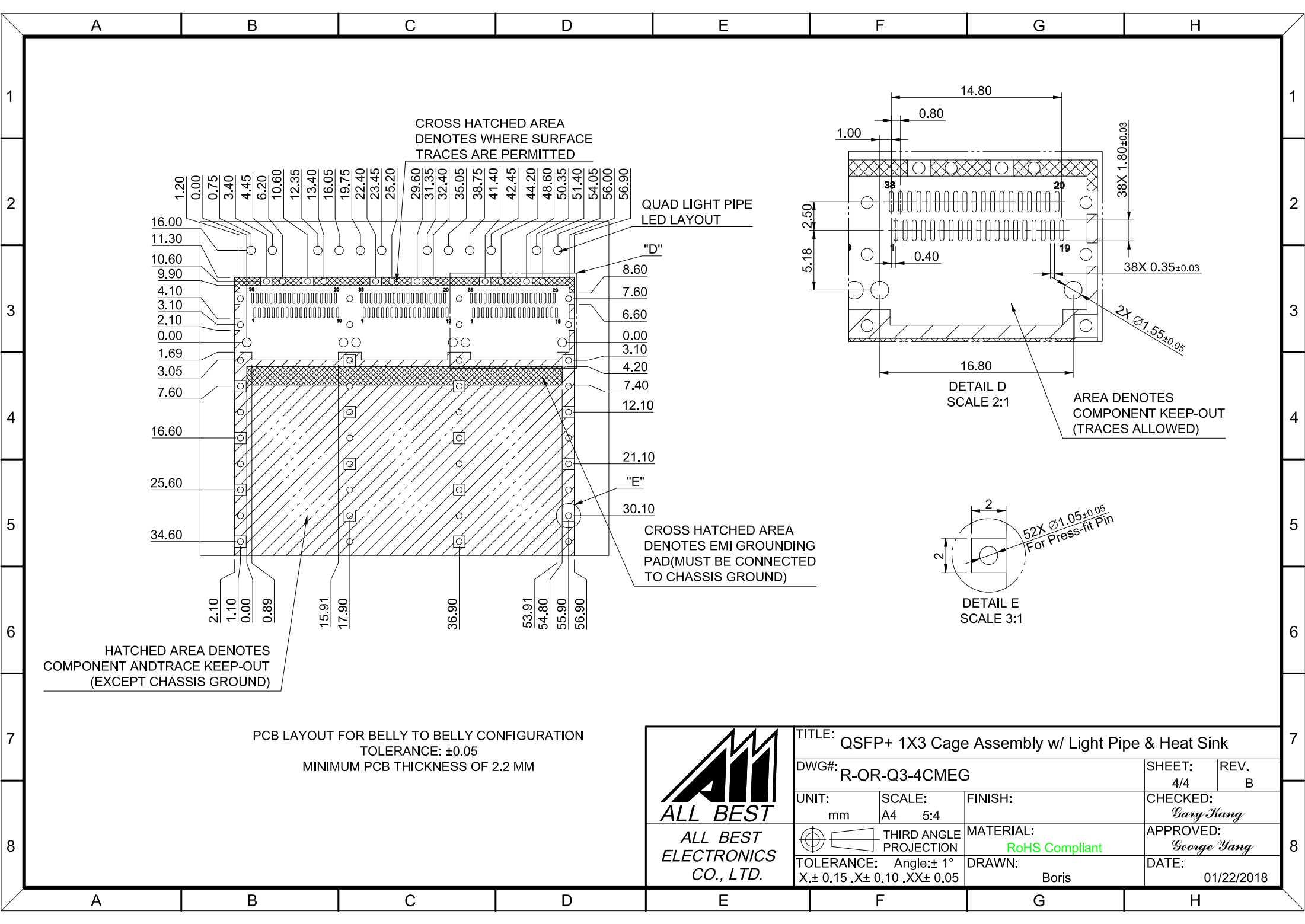

PCB LAYOUT FOR BELLY TO BELLY CONFIGURATION
 TOLERANCE: ±0.05
 MINIMUM PCB THICKNESS OF 2.2 MM

<p>ALL BEST ELECTRONICS CO., LTD.</p>		TITLE: QSFP+ 1X3 Cage Assembly w/ Light Pipe & Heat Sink	
		DWG#: R-OR-Q3-4CMEG	SHEET: 4/4 REV.: B
UNIT: mm	SCALE: A4 5:4	FINISH:	CHECKED: <i>Gary Kang</i>
THIRD ANGLE PROJECTION	TOLERANCE: Angle: ± 1° X: ± 0.15 .X: ± 0.10 .XX: ± 0.05	MATERIAL: RoHS Compliant	APPROVED: <i>George Yang</i>
		DRAWN: Boris	DATE: 01/22/2018