

DETAIL A
SCALE 5:1

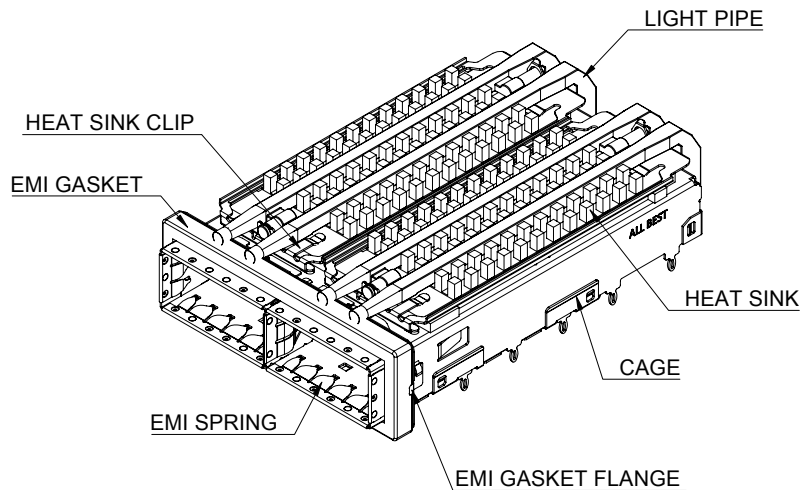

MATERIAL
 CAGE: NICKEL SILVER
 EMI SPRING: STAINLESS STEEL
 EMI GASKET FLANGE: STAINLESS STEEL
 EMI GASKET: CONDUCTIVE ELASTOMER
 HEAT SINK: ALUMINUM
 HEAT SINK CLIP: STAINLESS STEEL
 LIGHT PIPE: PC

FINISH
 HEAT SINK: ANODE PROCESS

NOTE
 ▲ DIMENSION APPLIES WITH MODULE INSERTED IN CAGE

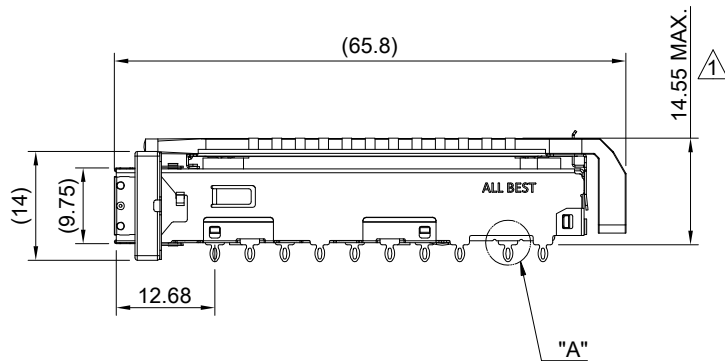
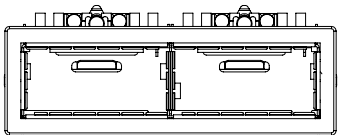

THIS PRINT IS
PRELIMINARY
 UNQUALIFIED PRODUCT
 CONTACT PRODUCT ENGINEERING
 BEFORE USING THIS PRINT



TITLE: QSFP56 1X2 Cage Assembly w/ Light Pipe & PCI Heat Sink

DWG#: R-OR-DZQ2-4CGE5-MK SHEET: 1/4 REV. REF

UNIT: mm SCALE: A4 1:1 FINISH: CHECKED:

MATERIAL: RoHS Compliant APPROVED:

TOLERANCE: Angle: ± 1° DRAWN: Pohsiung DATE: 3/14/2024
 X.± 0.25 .X± 0.20 .XX± 0.15

1
2
3
4
5
6
7
8

A B C D E F G H

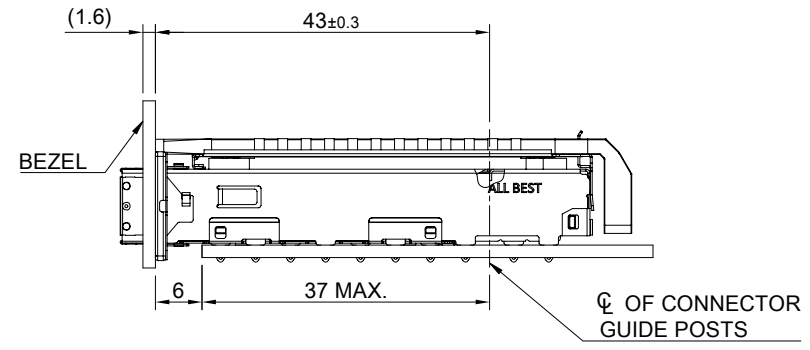
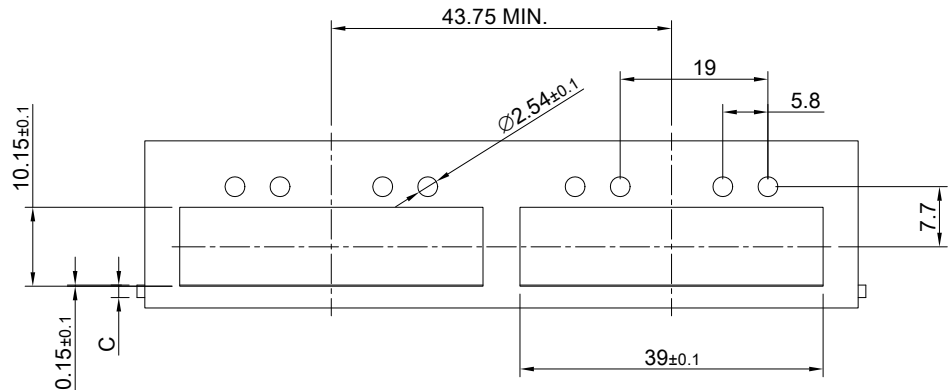

SINGLE-SIDE CONFIGURATION

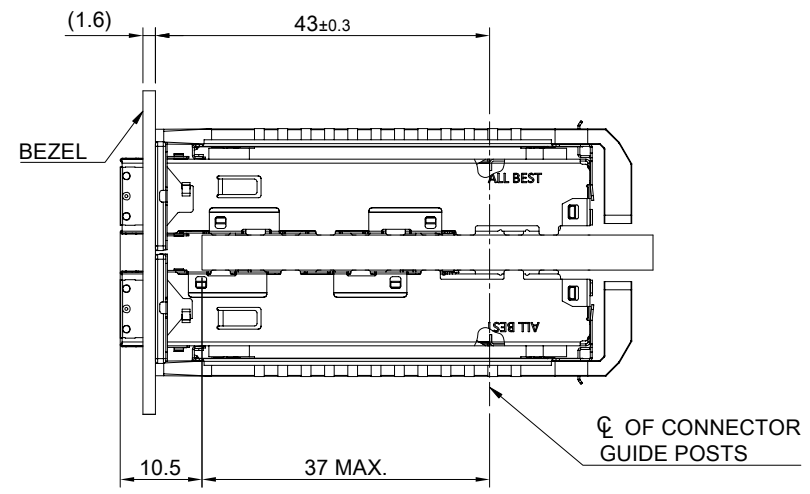
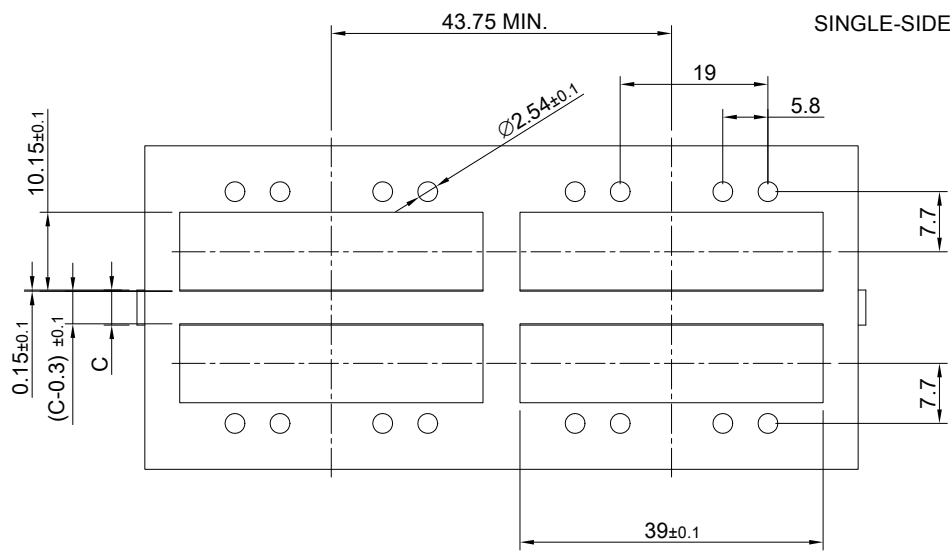

BELLY TO BELLY CONFIGURATION

C = THICKNESS OF PC BOARD
 SINGLE-SIDE = 1.6MM (MIN.)
 BELLY TO BELLY = 4.5MM (MIN.)

THIS PRINT IS
PRELIMINARY
 UNQUALIFIED PRODUCT
 CONTACT PRODUCT ENGINEERING
 BEFORE USING THIS PRINT

 ALL BEST ELECTRONICS CO., LTD.	TITLE: QSFP56 1X2 Cage Assembly w/ Light Pipe & PCI Heat Sink		SHEET: 2/4		REV.: REF	
	DWG#: R-OR-DZQ2-4CGE5-MK		CHECKED:		APPROVED:	
UNIT: mm	SCALE: A4 1:1	FINISH:		MATERIAL: RoHS Compliant		
TOLERANCE: Angle: ± 1° X ± 0.15 .X ± 0.10 .XX ± 0.05		THIRD ANGLE PROJECTION		DRAWN: Pohsiung		
			DATE: 3/14/2024			

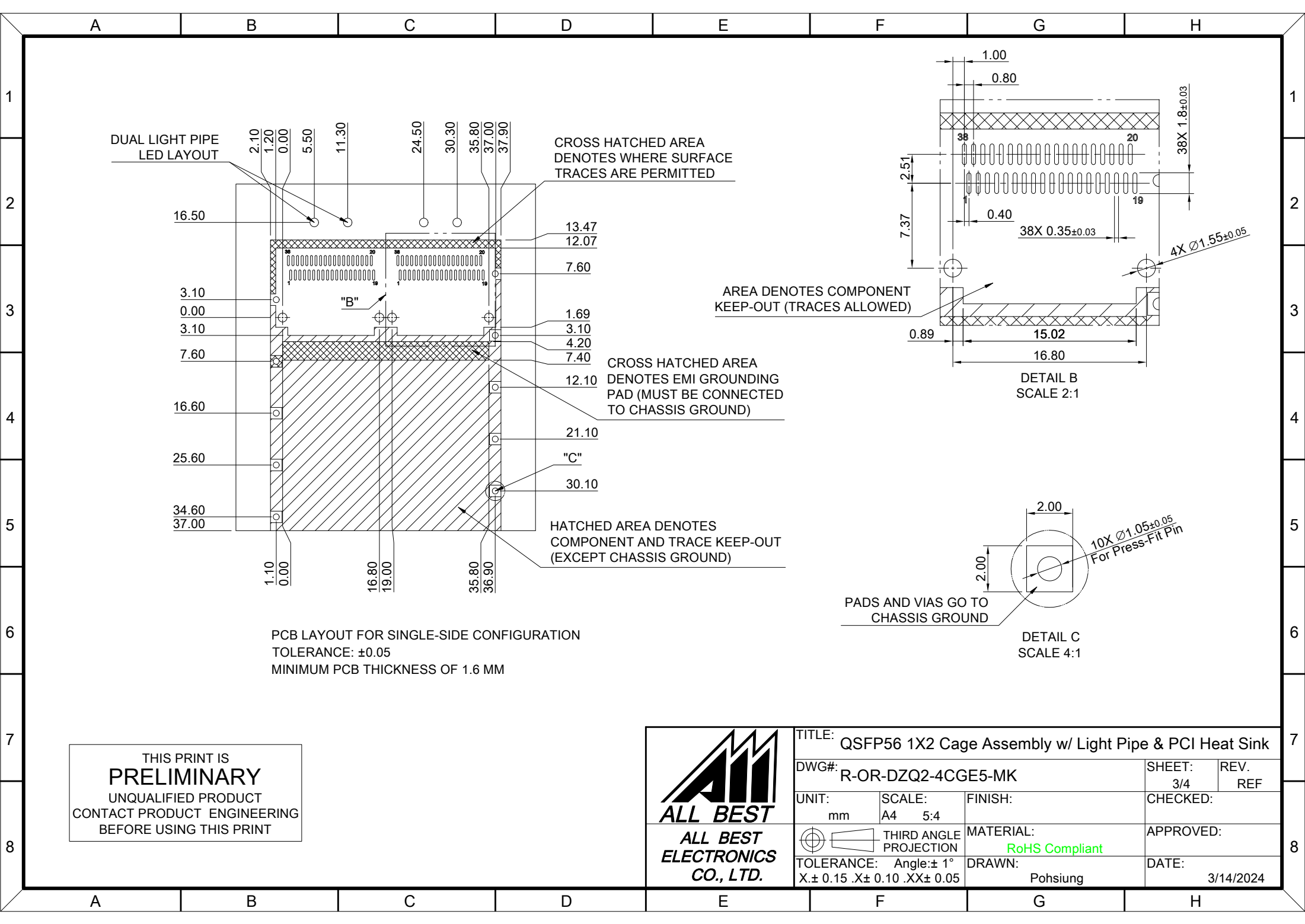

PCB LAYOUT FOR SINGLE-SIDE CONFIGURATION
 TOLERANCE: ±0.05
 MINIMUM PCB THICKNESS OF 1.6 MM

AREA DENOTES COMPONENT
 KEEP-OUT (TRACES ALLOWED)

CROSS HATCHED AREA
 DENOTES EMI GROUNDING
 PAD (MUST BE CONNECTED
 TO CHASSIS GROUND)

HATCHED AREA DENOTES
 COMPONENT AND TRACE KEEP-OUT
 (EXCEPT CHASSIS GROUND)

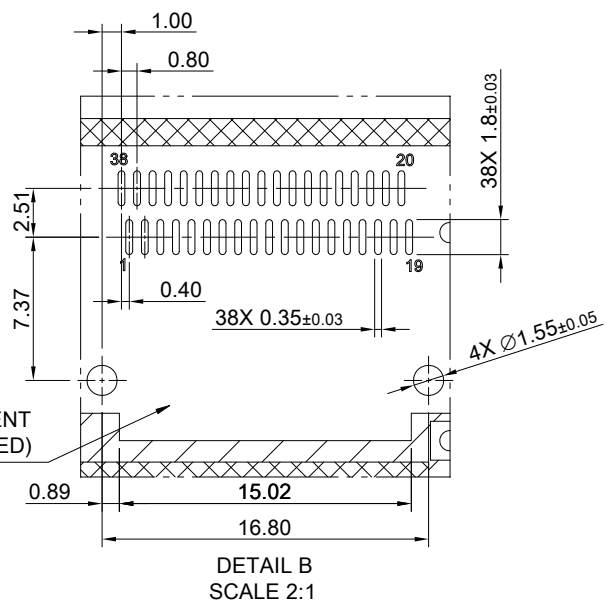

DETAIL B
 SCALE 2:1

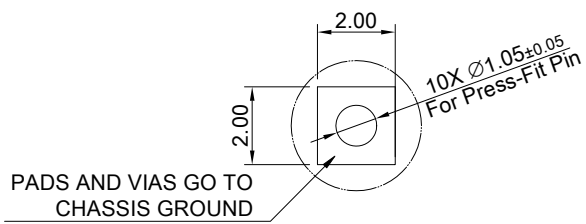

DETAIL C
 SCALE 4:1

THIS PRINT IS
PRELIMINARY
 UNQUALIFIED PRODUCT
 CONTACT PRODUCT ENGINEERING
 BEFORE USING THIS PRINT



TITLE: QSFP56 1X2 Cage Assembly w/ Light Pipe & PCI Heat Sink			
DWG#: R-OR-DZQ2-4CGE5-MK		SHEET: 3/4	REV. REF
UNIT: mm	SCALE: A4 5:4	CHECKED:	
THIRD ANGLE PROJECTION		APPROVED:	
TOLERANCE: Angle: ± 1° X ± 0.15 .X ± 0.10 .XX ± 0.05		MATERIAL: RoHS Compliant	DATE: 3/14/2024
		DRAWN: Pohsiung	

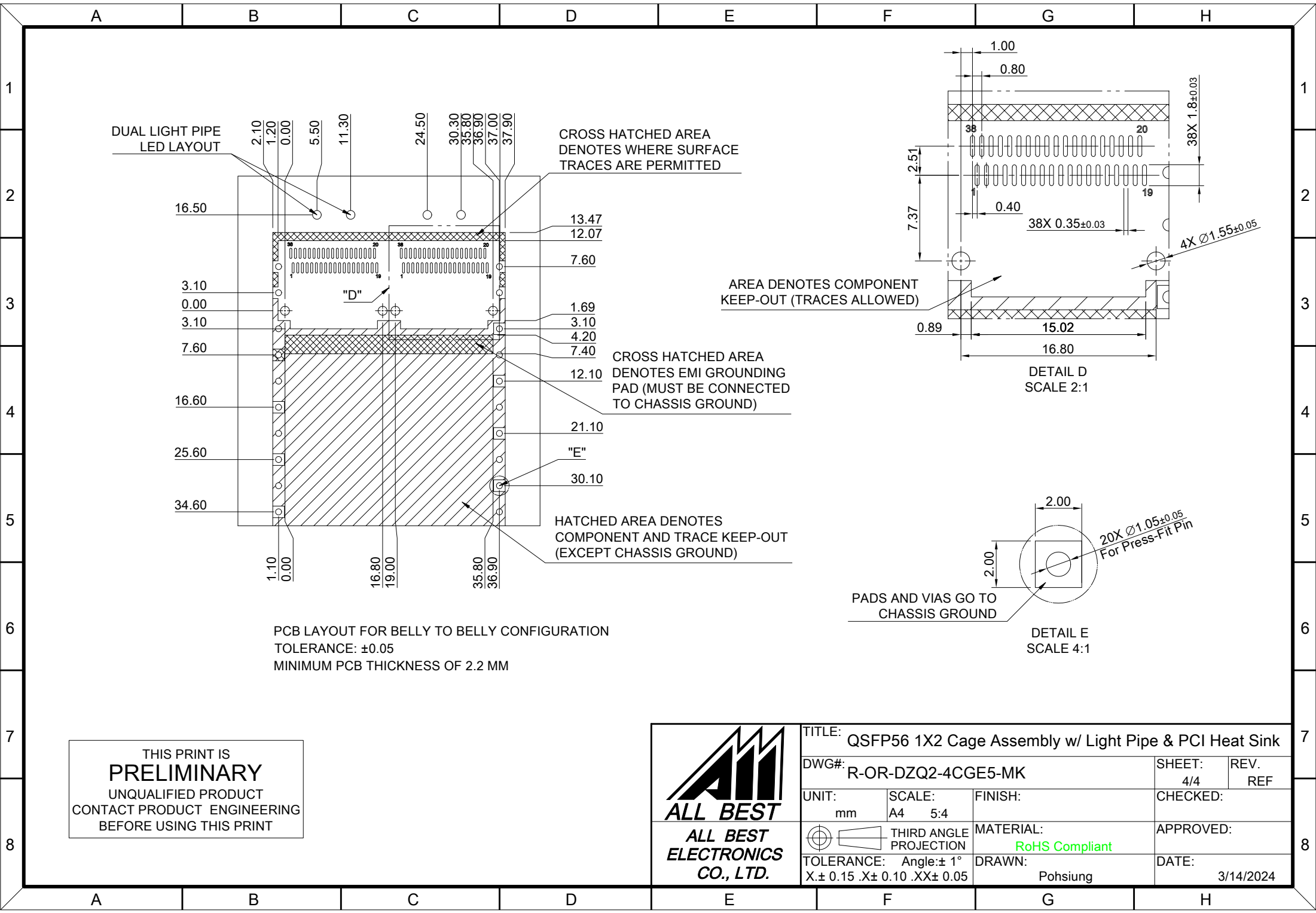

PCB LAYOUT FOR BELLY TO BELLY CONFIGURATION
 TOLERANCE: ±0.05
 MINIMUM PCB THICKNESS OF 2.2 MM

THIS PRINT IS
PRELIMINARY
 UNQUALIFIED PRODUCT
 CONTACT PRODUCT ENGINEERING
 BEFORE USING THIS PRINT

 ALL BEST ELECTRONICS CO., LTD.	TITLE: QSFP56 1X2 Cage Assembly w/ Light Pipe & PCI Heat Sink		SHEET: 4/4		REV. REF	
	DWG#: R-OR-DZQ2-4CGE5-MK		CHECKED:		APPROVED:	
UNIT: mm	SCALE: A4 5:4	FINISH:		MATERIAL: RoHS Compliant		
TOLERANCE: Angle: ± 1° X: ± 0.15 .X: ± 0.10 .XX: ± 0.05		DRAWN: Pohsiung		DATE: 3/14/2024		

