

DETAIL A
SCALE 4:1

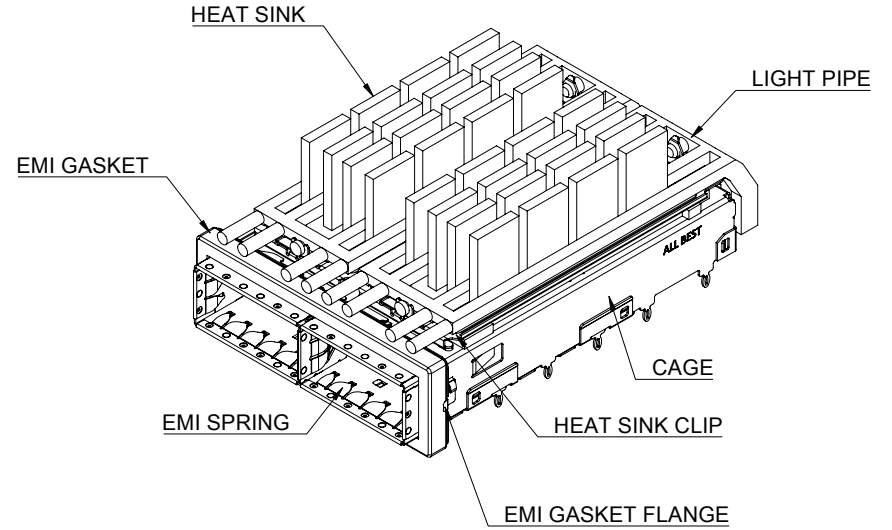
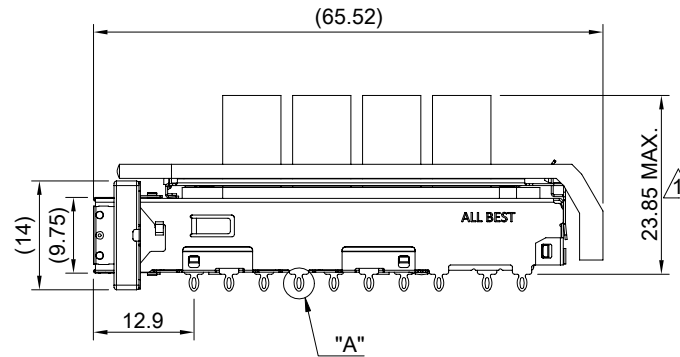
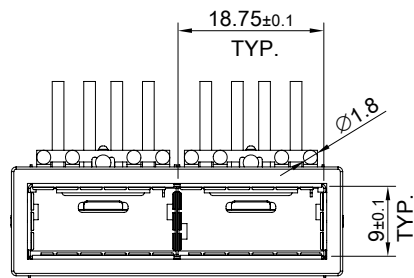

MATERIAL
 CAGE: NICKEL SILVER
 EMI SPRING: STAINLESS STEEL
 EMI GASKET FLANGE: STAINLESS STEEL
 EMI GASKET: CONDUCTIVE ELASTOMER
 HEAT SINK: ALUMINUM
 HEAT SINK CLIP: STAINLESS STEEL
 LIGHT PIPE: PC

FINISH
 HEAT SINK: ANODE PROCESS

NOTE
 ▲ DIMENSION APPLIES WITH MODULE INSERTED IN CAGE

THIS PRINT IS
PRELIMINARY
 UNQUALIFIED PRODUCT
 CONTACT PRODUCT ENGINEERING
 BEFORE USING THIS PRINT



TITLE: QSFP56 1X2 Cage Assembly w/ Light Pipe & NET Heat Sink			
DWG#: R-OR-DZQ2-4CGEE-MK		SHEET: 1/4	REV. REF
UNIT: mm	SCALE: A4 1:1	CHECKED:	
TOLERANCE: Angle: ± 1° X.± 0.25 .X± 0.20 .XX± 0.15		MATERIAL: RoHS Compliant	APPROVED:
THIRD ANGLE PROJECTION		DRAWN: Pohsiung	DATE: 3/14/2024

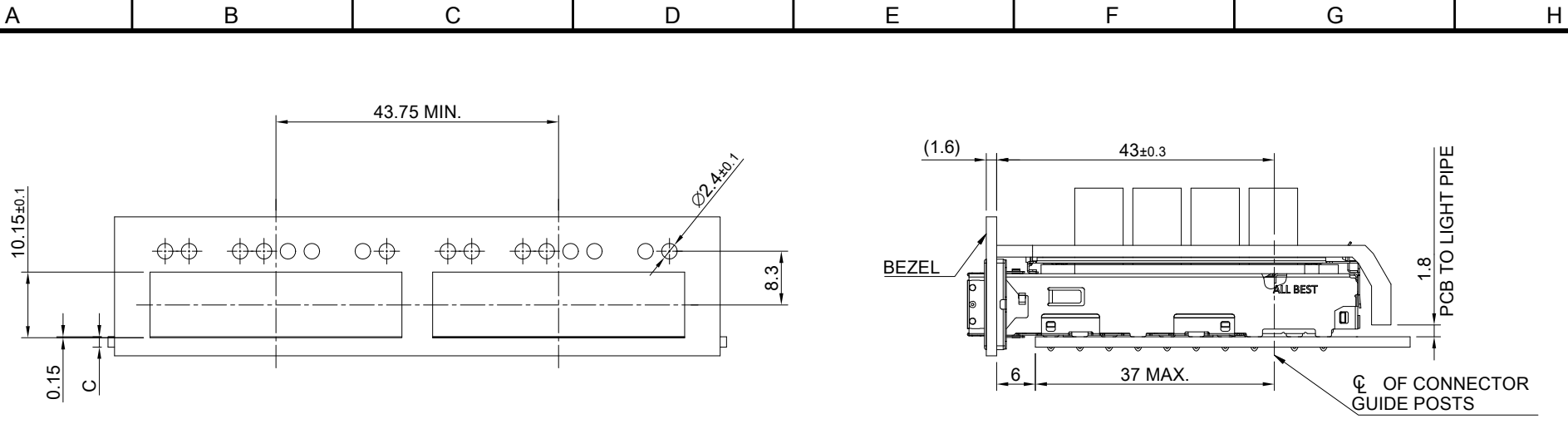

SINGLE-SIDE CONFIGURATION

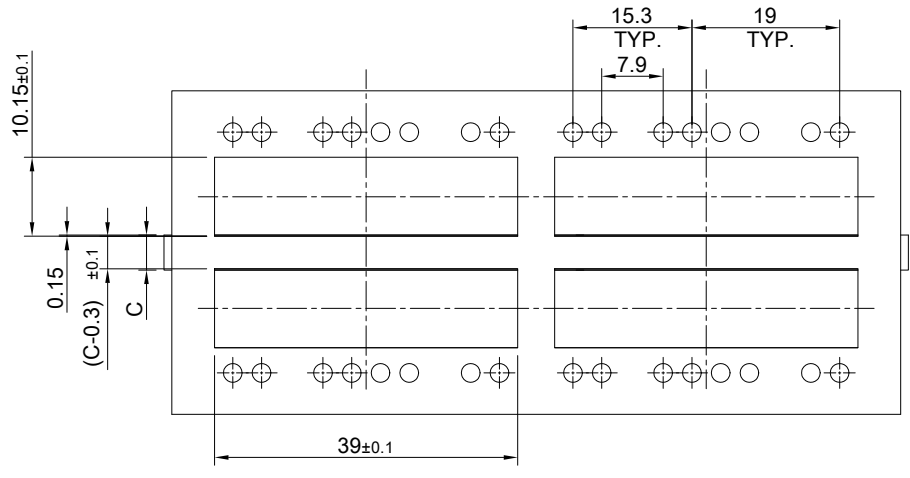

BELLY TO BELLY CONFIGURATION

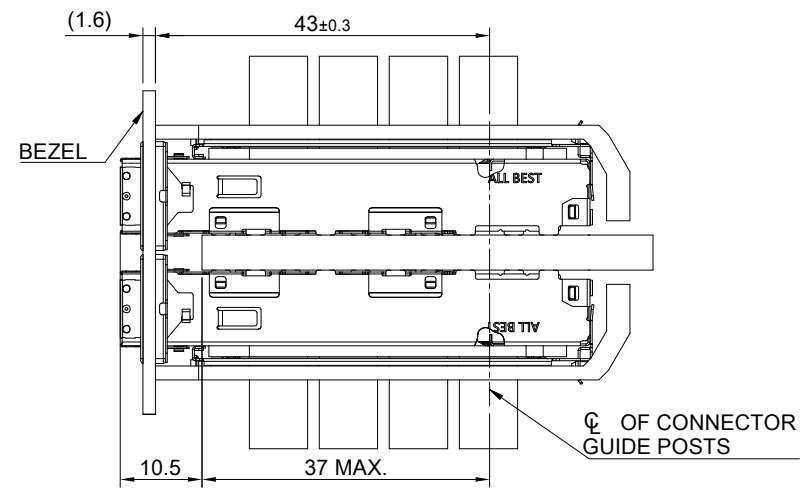

C = THICKNESS OF PC BOARD
 SINGLE-SIDE = 1.6MM (MIN.)
 BELLY TO BELLY = 4.5MM (MIN.)

THIS PRINT IS
PRELIMINARY
 UNQUALIFIED PRODUCT
 CONTACT PRODUCT ENGINEERING
 BEFORE USING THIS PRINT



TITLE: QSFP56 1X2 Cage Assembly w/ Light Pipe & NET Heat Sink			
DWG#: R-OR-DZQ2-4CGEE-MK		SHEET: 2/4	REV. REF
UNIT: mm	SCALE: A4 1:1	FINISH:	
THIRD ANGLE PROJECTION		MATERIAL: RoHS Compliant	
TOLERANCE: Angle: ± 1°		DRAWN: Pohsiung	
X.± 0.15 .X± 0.10 .XX± 0.05		DATE: 3/14/2024	

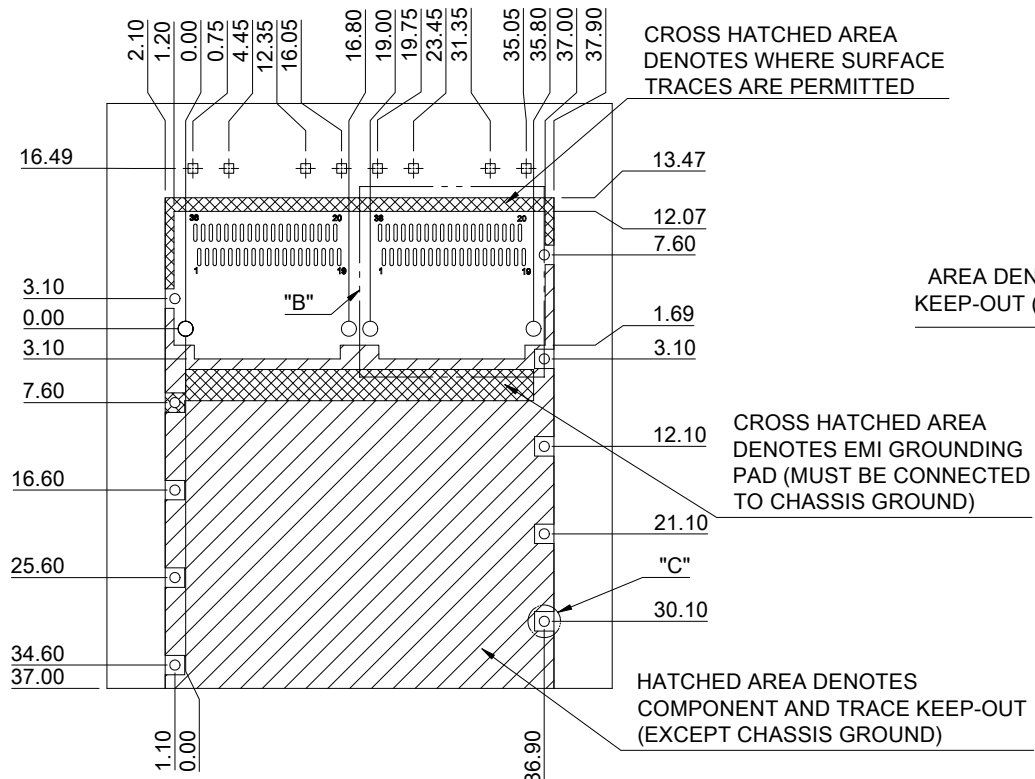

PCB LAYOUT FOR SINGLE-SIDE CONFIGURATION
 TOLERANCE: ± 0.05
 MINIMUM PCB THICKNESS OF 1.6 MM

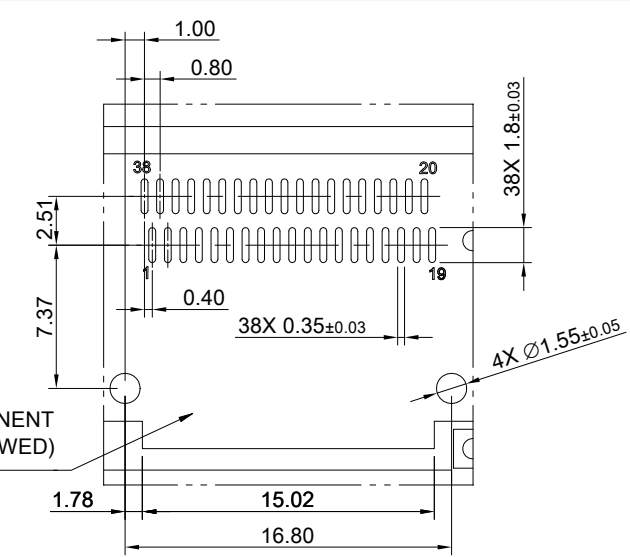

DETAIL B
 SCALE 2:1

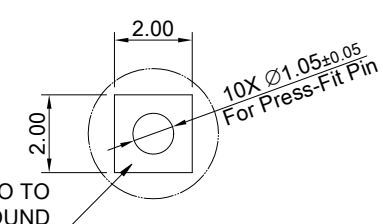

DETAIL C
 SCALE 4:1

THIS PRINT IS
PRELIMINARY
 UNQUALIFIED PRODUCT
 CONTACT PRODUCT ENGINEERING
 BEFORE USING THIS PRINT

	TITLE: QSFP56 1X2 Cage Assembly w/ Light Pipe & NET Heat Sink		
	DWG#: R-OR-DZQ2-4CGEE-MK		SHEET: 3/4
UNIT: mm	SCALE: A4 5:4	FINISH:	CHECKED:
THIRD ANGLE PROJECTION		MATERIAL: RoHS Compliant	APPROVED:
TOLERANCE: Angle: $\pm 1^\circ$ X: ± 0.15 .X: ± 0.10 .XX: ± 0.05		DRAWN: Pohsiung	DATE: 3/14/2024

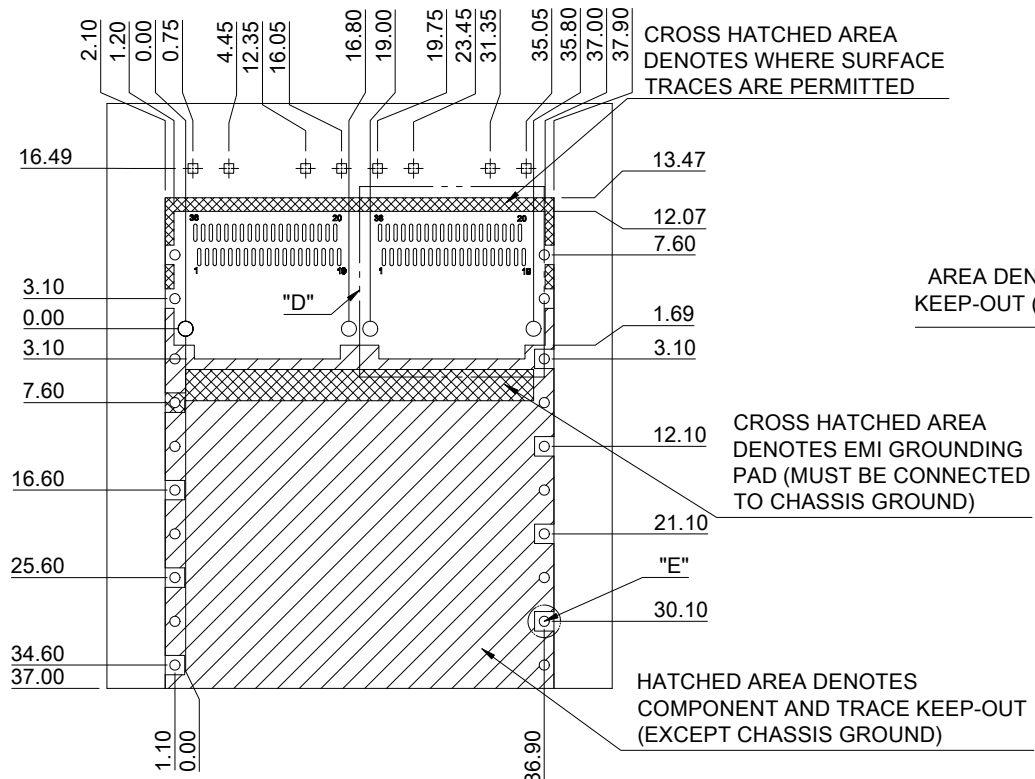

PCB LAYOUT FOR BELLY TO BELLY CONFIGURATION
 TOLERANCE: ± 0.05
 MINIMUM PCB THICKNESS OF 4.5 MM

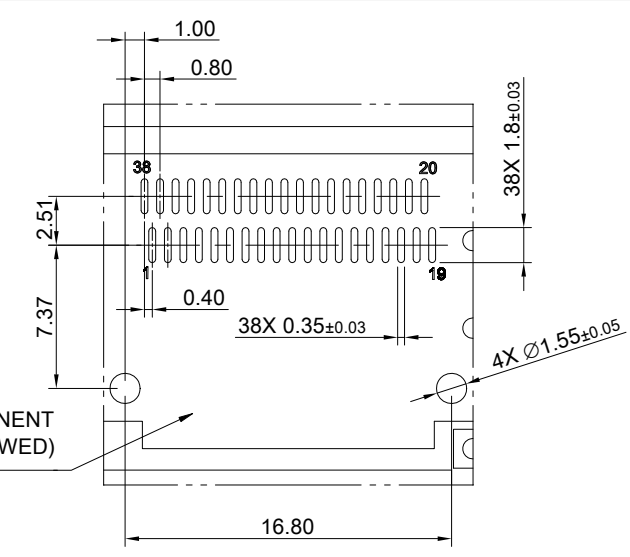

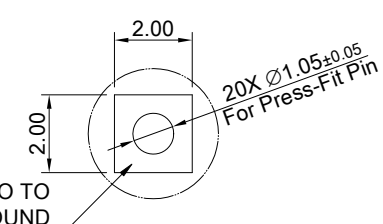

DETAIL D
 SCALE 2:1



DETAIL E
 SCALE 4:1

PADS AND VIAS GO TO CHASSIS GROUND

THIS PRINT IS
PRELIMINARY
 UNQUALIFIED PRODUCT
 CONTACT PRODUCT ENGINEERING
 BEFORE USING THIS PRINT

 ALL BEST ELECTRONICS CO., LTD.	TITLE: QSFP56 1X2 Cage Assembly w/ Light Pipe & NET Heat Sink		SHEET: 4/4		REV. REF	
	DWG#: R-OR-DZQ2-4CGEE-MK		CHECKED:		APPROVED:	
UNIT: mm	SCALE: A4 5:4	FINISH:		DATE: 3/14/2024		
 THIRD ANGLE PROJECTION		MATERIAL: RoHS Compliant		DRAWN: Pohsiung		
TOLERANCE: Angle: $\pm 1^\circ$ X: ± 0.15 .X: ± 0.10 .XX: ± 0.05		DRAWN: Pohsiung		DATE: 3/14/2024		