

DETAIL A  
SCALE 5:1

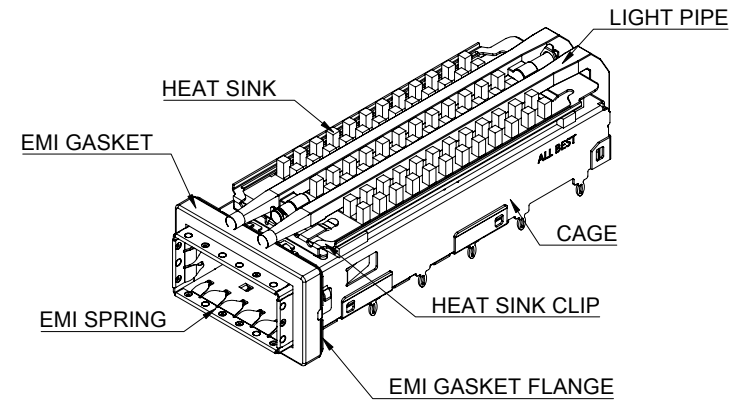

MATERIAL  
 CAGE: NICKEL SILVER  
 EMI SPRING: STAINLESS STEEL  
 HEAT SINK: ALUMINUM  
 HEAT SINK CLIP: STAINLESS STEEL  
 LIGHT PIPE: PC  
 EMI GASKET: CONDUCTIVE ELASTOMER  
 EMI GASKET FLANGE: STAINLESS STEEL

FINISH  
 HEAT SINK: ANODE PROCESS

NOTE  
 ▲ DIMENSION APPLIES WITH MODULE INSERTED IN CAGE

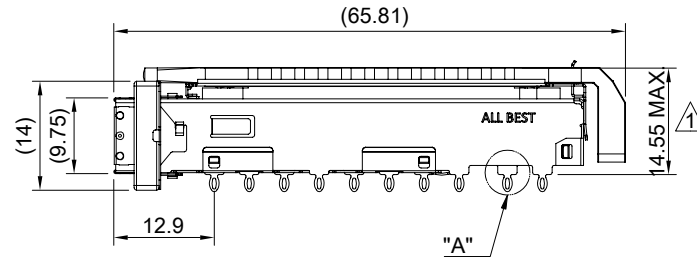
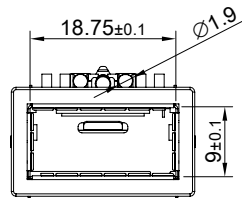

THIS PRINT IS  
**PRELIMINARY**  
 UNQUALIFIED PRODUCT  
 CONTACT PRODUCT ENGINEERING  
 BEFORE USING THIS PRINT



TITLE: QSFP56 1X1 Cage w/ Light Pipe & Heat Sink (PCI)			
DWG#: R-OR-DZQ1-4CGE5-MK		SHEET: 1/4	REV. REF
UNIT: mm	SCALE: A4 1:1	FINISH:	CHECKED:
TOLERANCE: Angle: ± 1° X.± 0.25 .X± 0.20 .XX± 0.15		MATERIAL: RoHS Compliant	APPROVED:
THIRD ANGLE PROJECTION		DRAWN: Pohsiung	DATE: 3/14/2024

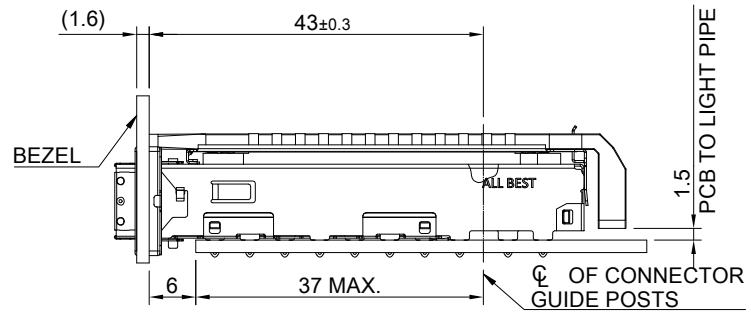
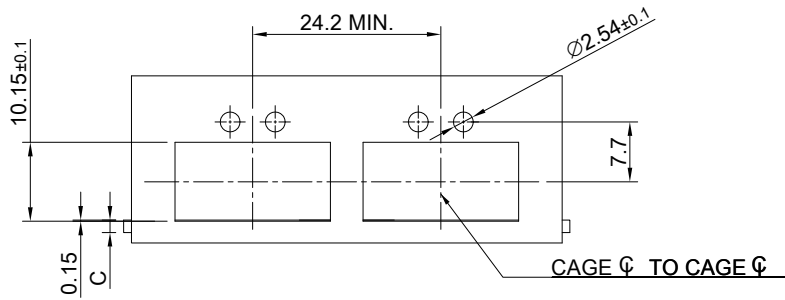

SINGLE-SIDE CONFIGURATION

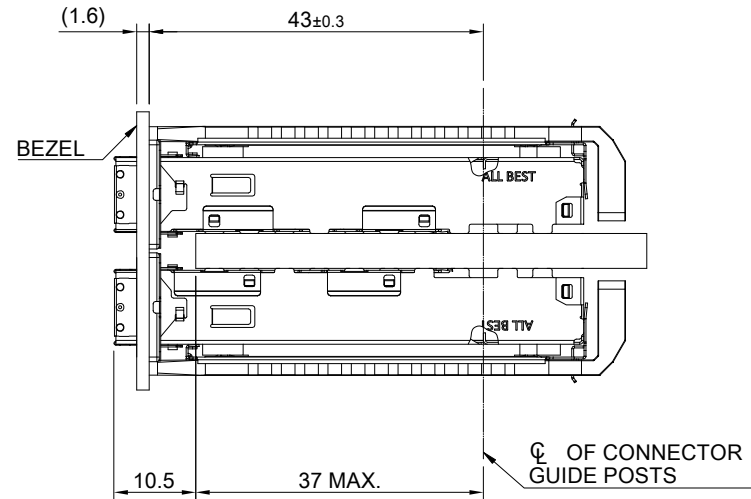
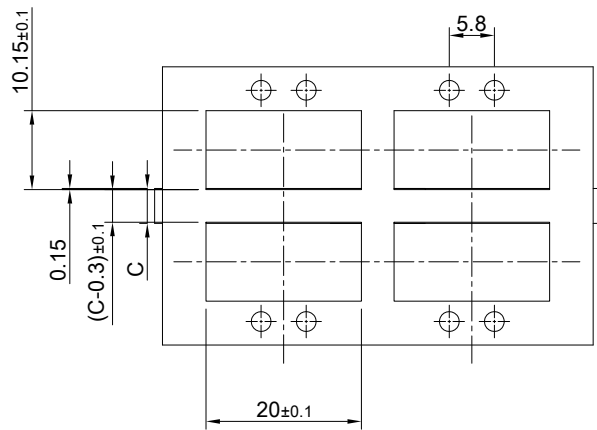

BELLY TO BELLY CONFIGURATION

C = THICKNESS OF PC BOARD  
 SINGLE-SIDE = 1.6MM (MIN.)  
 BELLY TO BELLY = 4.5MM (MIN.)

THIS PRINT IS  
**PRELIMINARY**  
 UNQUALIFIED PRODUCT  
 CONTACT PRODUCT ENGINEERING  
 BEFORE USING THIS PRINT



TITLE: QSFP56 1X1 Cage w/ Light Pipe & Heat Sink (PCI)

DWG#: R-OR-DZQ1-4CGE5-MK

UNIT: mm

SCALE: A4 1:1

FINISH:

SHEET: 2/4  
 REV. REF

THIRD ANGLE PROJECTION

MATERIAL: RoHS Compliant

APPROVED:

TOLERANCE: Angle: ± 1°  
 X.± 0.15 .X± 0.10 .XX± 0.05

DRAWN: Pohsiung

DATE: 3/14/2024

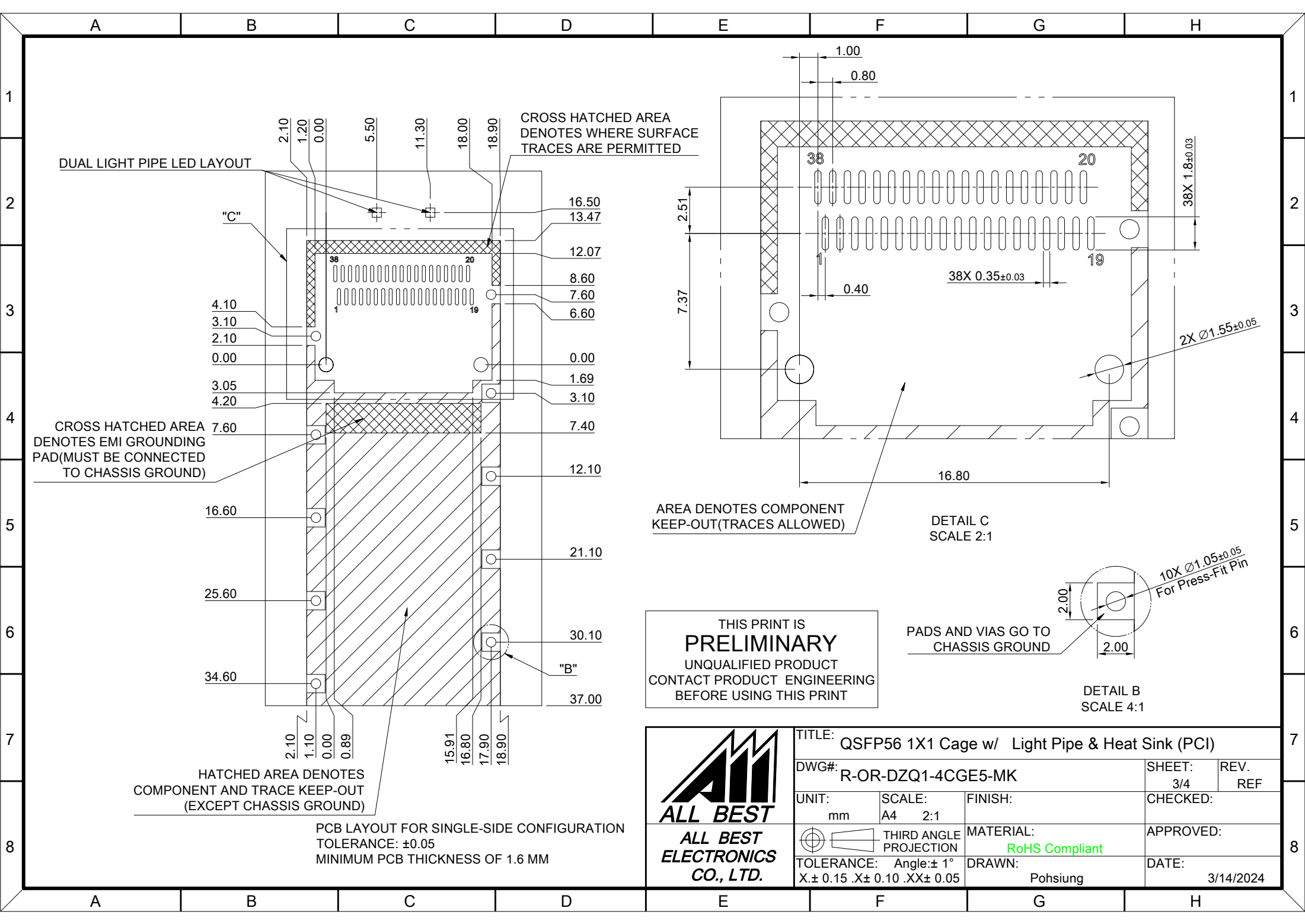

DUAL LIGHT PIPE LED LAYOUT

CROSS HATCHED AREA DENOTES WHERE SURFACE TRACES ARE PERMITTED

CROSS HATCHED AREA DENOTES EMI GROUNDING PAD (MUST BE CONNECTED TO CHASSIS GROUND)

HATCHED AREA DENOTES COMPONENT AND TRACE KEEP-OUT (EXCEPT CHASSIS GROUND)

PCB LAYOUT FOR SINGLE-SIDE CONFIGURATION  
TOLERANCE: ±0.05  
MINIMUM PCB THICKNESS OF 1.6 MM

AREA DENOTES COMPONENT KEEP-OUT (TRACES ALLOWED)

DETAIL C  
SCALE 2:1

PADS AND VIAS GO TO CHASSIS GROUND

DETAIL B  
SCALE 4:1

THIS PRINT IS  
**PRELIMINARY**  
UNQUALIFIED PRODUCT  
CONTACT PRODUCT ENGINEERING  
BEFORE USING THIS PRINT



TITLE: QSFP56 1X1 Cage w/ Light Pipe & Heat Sink (PCI)			
DWG#: R-OR-DZQ1-4CGE5-MK		SHEET: 3/4	REV. REF
UNIT: mm	SCALE: A4 2:1	CHECKED:	
THIRD ANGLE PROJECTION		APPROVED:	
TOLERANCE: Angle: ±1° X ± 0.15 .X ± 0.10 .XX ± 0.05		MATERIAL: RoHS Compliant	DATE: 3/14/2024
		DRAWN: Pohsiung	

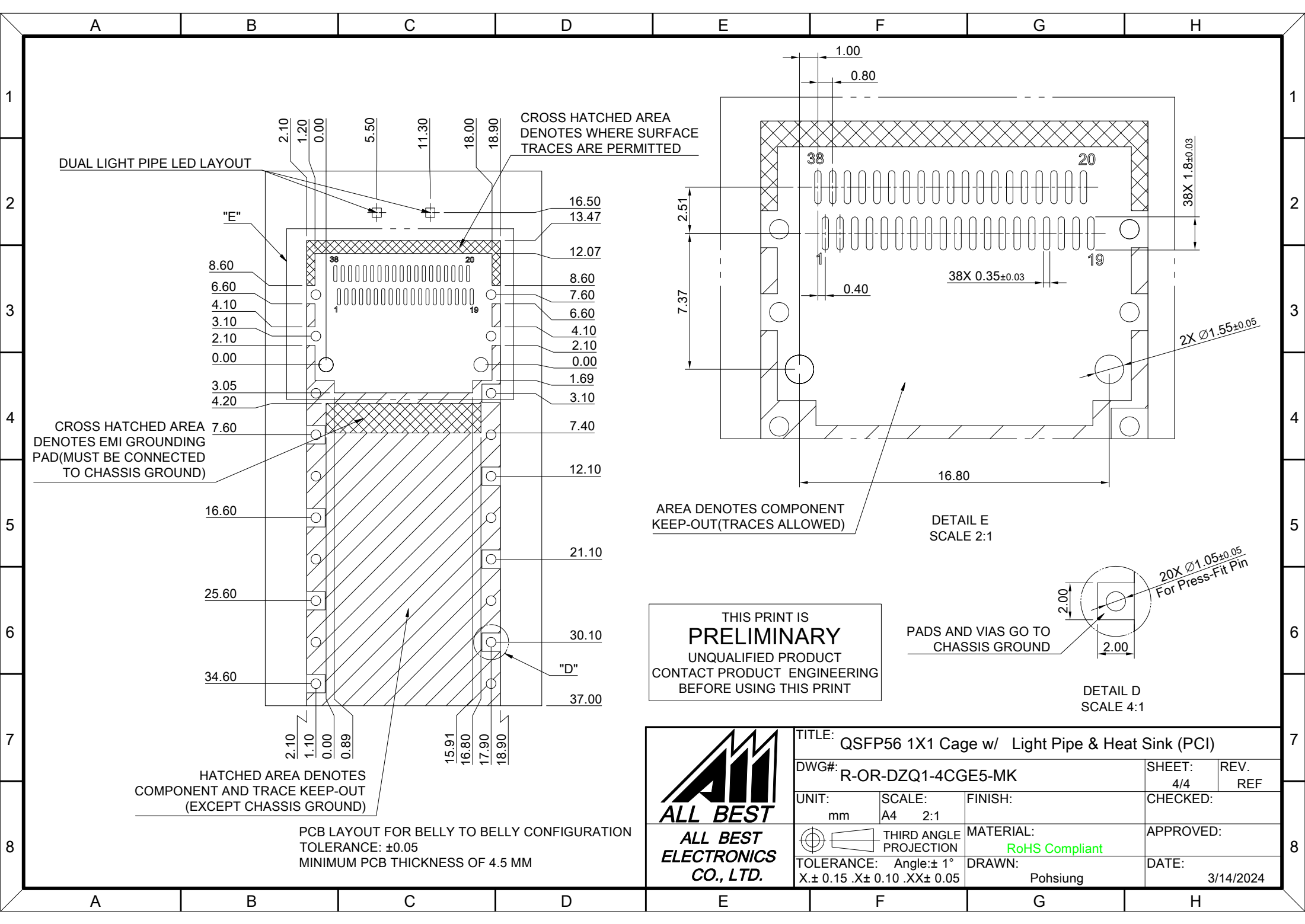

DUAL LIGHT PIPE LED LAYOUT

CROSS HATCHED AREA DENOTES WHERE SURFACE TRACES ARE PERMITTED

CROSS HATCHED AREA DENOTES EMI GROUNDING PAD (MUST BE CONNECTED TO CHASSIS GROUND)

HATCHED AREA DENOTES COMPONENT AND TRACE KEEP-OUT (EXCEPT CHASSIS GROUND)

PCB LAYOUT FOR BELLY TO BELLY CONFIGURATION  
TOLERANCE: ±0.05  
MINIMUM PCB THICKNESS OF 4.5 MM

AREA DENOTES COMPONENT KEEP-OUT (TRACES ALLOWED)

DETAIL E  
SCALE 2:1

PADS AND VIAS GO TO CHASSIS GROUND

DETAIL D  
SCALE 4:1

THIS PRINT IS PRELIMINARY  
UNQUALIFIED PRODUCT  
CONTACT PRODUCT ENGINEERING  
BEFORE USING THIS PRINT



TITLE: QSFP56 1X1 Cage w/ Light Pipe & Heat Sink (PCI)			
DWG#: R-OR-DZQ1-4CGE5-MK		SHEET: 4/4	REV. REF
UNIT: mm	SCALE: A4 2:1	CHECKED:	
THIRD ANGLE PROJECTION		APPROVED:	
TOLERANCE: Angle: ±1° X ± 0.15 .X ± 0.10 .XX ± 0.05		MATERIAL: RoHS Compliant	DATE: 3/14/2024
		DRAWN: Pohsiung	