

DETAIL A
SCALE 4:1

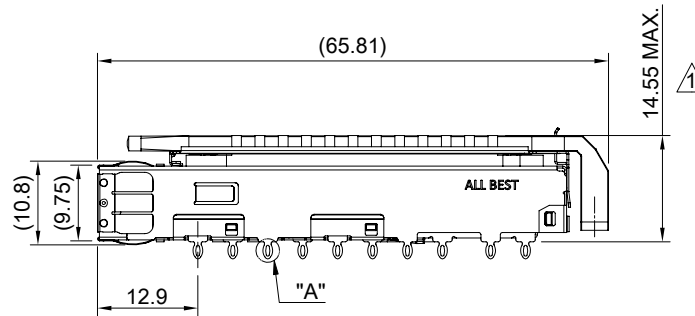
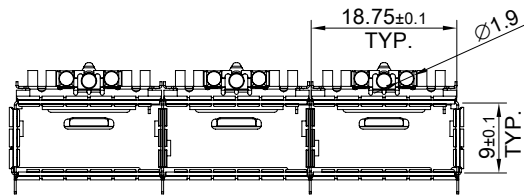
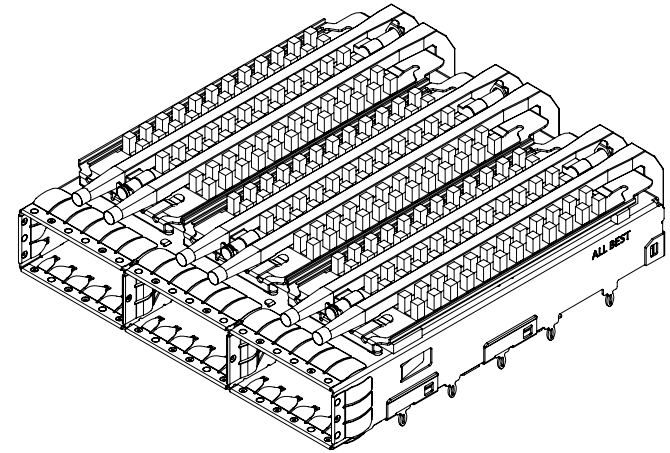

MATERIAL
 CAGE: NICKEL SILVER
 EMI SPRING: STAINLESS STEEL
 HEAT SINK: ALUMINUM
 HEAT SINK CLIP: STAINLESS STEEL
 LIGHT PIPE: PC

FINISH
 HEAT SINK: ANODE PROCESS

NOTE
 ▲ DIMENSION APPLIES WITH MODULE INSERTED IN CAGE

	TITLE: QSFP28 1X3 Cage Assembly w/ Light Pipe & Heat Sink(PCI)		SHEET: 1/4	REV. B
	DWG#: R-OR-ZQ3-4CME5-MK		CHECKED: Gary Kang	
	UNIT: mm	SCALE: A4 1:1	APPROVED: George Yang	
	TOLERANCE: Angle: ± 1° X ± 0.25 .X ± 0.20 .XX ± 0.15		MATERIAL: RoHS Compliant	DATE: 04/28/2020
THIRD ANGLE PROJECTION		DRAWN: Calvin		

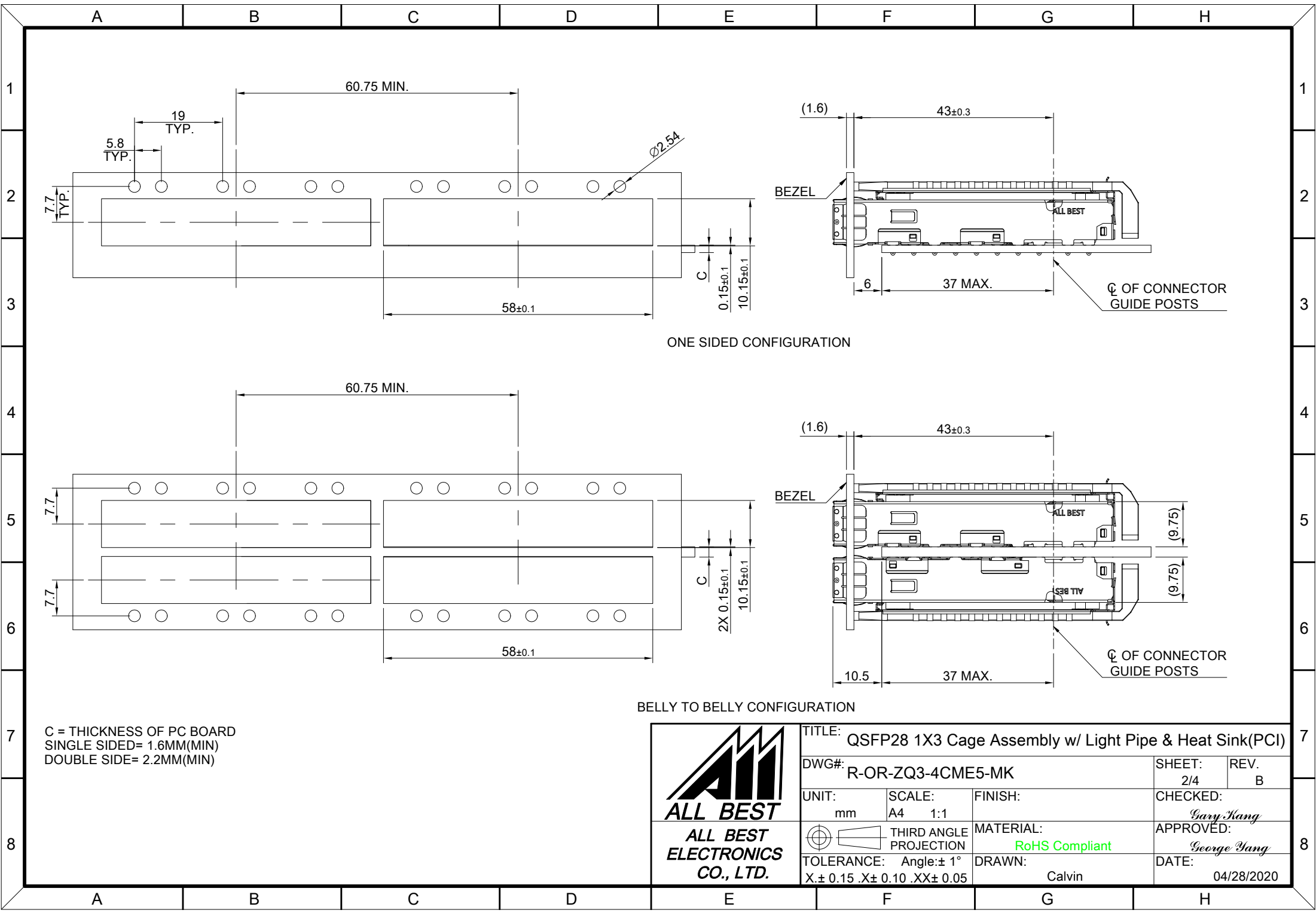

ONE SIDED CONFIGURATION

BELLY TO BELLY CONFIGURATION

C = THICKNESS OF PC BOARD
 SINGLE SIDED= 1.6MM(MIN)
 DOUBLE SIDE= 2.2MM(MIN)

 ALL BEST ELECTRONICS CO., LTD.	TITLE: QSFP28 1X3 Cage Assembly w/ Light Pipe & Heat Sink(PCI)		SHEET: 2/4	REV. B
	DWG#: R-OR-ZQ3-4CME5-MK		CHECKED: Gary Kang	
	UNIT: mm	SCALE: A4 1:1	APPROVED: George Yang	
	TOLERANCE: Angle: ± 1° X ± 0.15 .X ± 0.10 .XX ± 0.05		MATERIAL: RoHS Compliant	DATE: 04/28/2020
		THIRD ANGLE PROJECTION	DRAWN: Calvin	

DUAL LIGHT PIPE LED LAYOUT

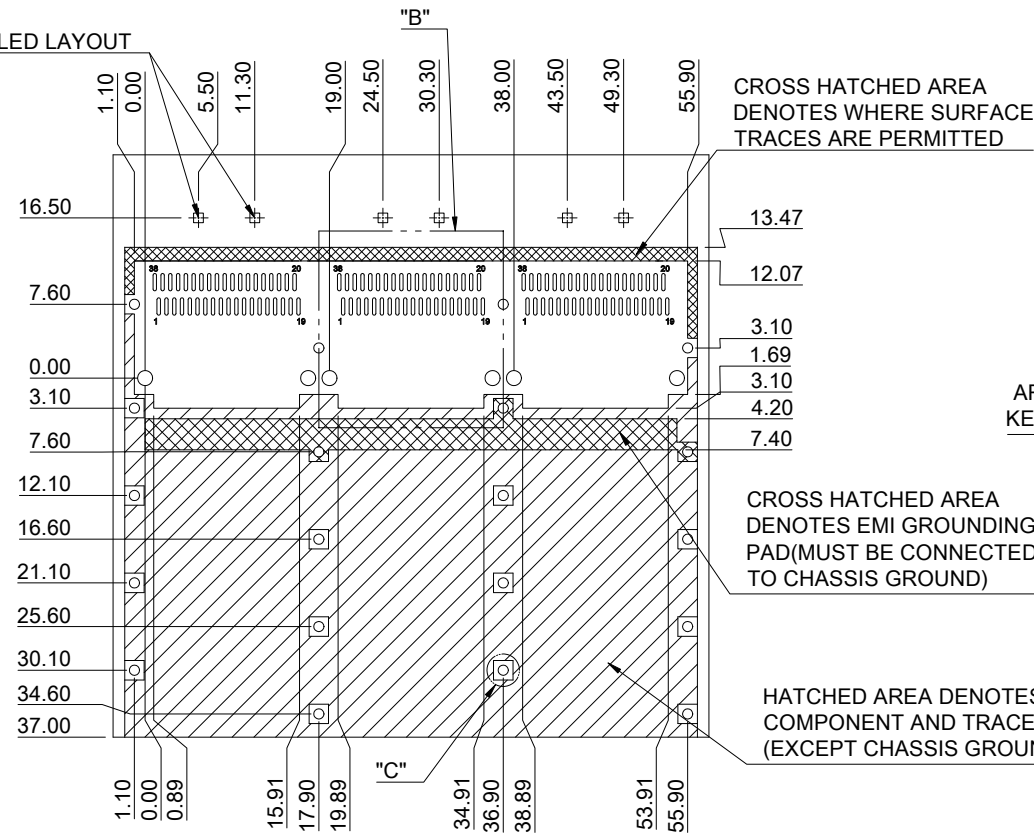

AREA DENOTES COMPONENT KEEP-OUT (TRACES ALLOWED)

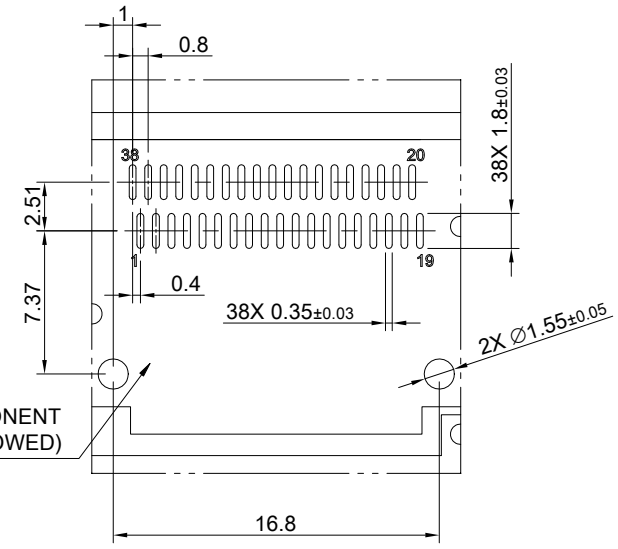

DETAIL B
SCALE 2:1

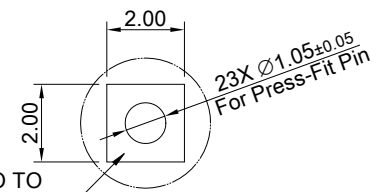

DETAIL C
SCALE 4:1

PADS AND VIAS GO TO CHASSIS GROUND

SINGLE SIDE PCB LAYOUT
TOLERANCE: ±0.05
MINIMUM PCB THICKNESS OF 1.6 MM

	TITLE: QSFP28 1X3 Cage Assembly w/ Light Pipe & Heat Sink(PCI)		SHEET: 3/4	REV. B
	DWG#: R-OR-ZQ3-4CME5-MK		CHECKED: Gary Kang	
	UNIT: mm	SCALE: A4 5:4	APPROVED: George Yang	
	TOLERANCE: Angle: ± 1° X ± 0.15 .X ± 0.10 .XX ± 0.05		MATERIAL: RoHS Compliant	DATE: 04/28/2020
		DRAWN: Calvin		

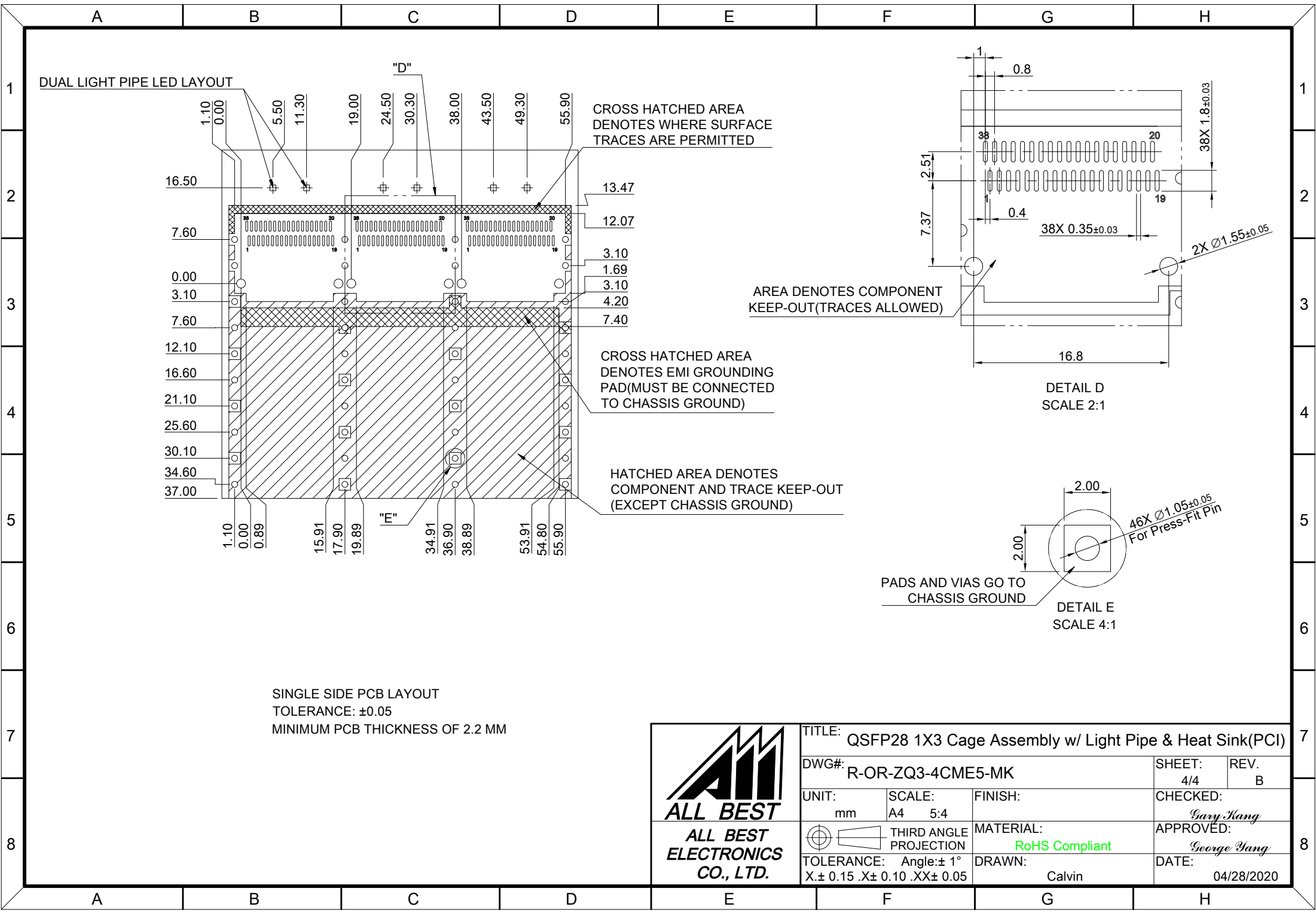

DUAL LIGHT PIPE LED LAYOUT

CROSS HATCHED AREA DENOTES WHERE SURFACE TRACES ARE PERMITTED

AREA DENOTES COMPONENT KEEP-OUT (TRACES ALLOWED)

CROSS HATCHED AREA DENOTES EMI GROUNDING PAD (MUST BE CONNECTED TO CHASSIS GROUND)

HATCHED AREA DENOTES COMPONENT AND TRACE KEEP-OUT (EXCEPT CHASSIS GROUND)

DETAIL D SCALE 2:1

DETAIL E SCALE 4:1

SINGLE SIDE PCB LAYOUT
TOLERANCE: ±0.05
MINIMUM PCB THICKNESS OF 2.2 MM

<p>ALL BEST ALL BEST ELECTRONICS CO., LTD.</p>	TITLE: QSFP28 1X3 Cage Assembly w/ Light Pipe & Heat Sink(PCI)		SHEET: 4/4		REV. B
	DWG#: R-OR-ZQ3-4CME5-MK		CHECKED: Gary Kang		APPROVED: George Yang
	UNIT: mm	SCALE: A4 5:4	FINISH:	MATERIAL: RoHS Compliant	
	TOLERANCE: X±0.15 .X±0.10 .XX±0.05		THIRD ANGLE PROJECTION	DRAWN: Calvin	DATE: 04/28/2020