

DETAIL A
SCALE 4:1

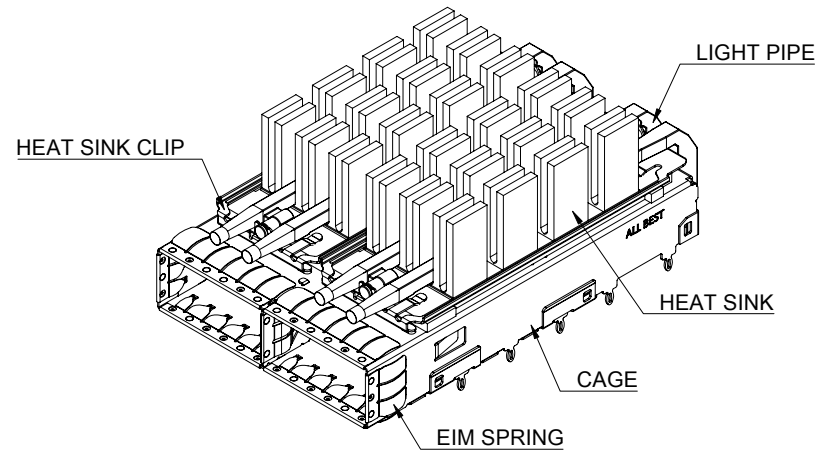
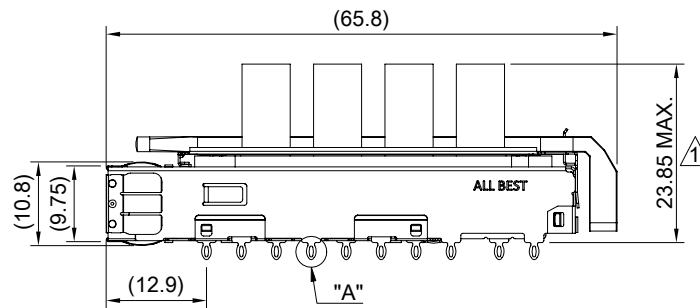
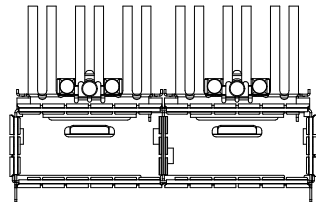

MATERIAL
 CAGE: NICKEL SILVER
 HEAT SINK: ALUMINUM
 HEAT SINK CLIP: STAINLESS STEEL
 EMI SPRING: STAINLESS STEEL
 LIGHT PIPE: PC

FINISH
 HEAT SINK: ANODE PROCESS

NOTE
 ▲ DIMENSION APPLIES WITH MODULE INSERTED IN CAGE

THIS PRINT IS
PRELIMINARY
 UNQUALIFIED PRODUCT
 CONTACT PRODUCT ENGINEERING
 BEFORE USING THIS PRINT



TITLE: QSFP28 1X2 Cage w/ Light Pipe & NET Heat Sink			
DWG#: R-OR-ZQ2-4CMED-MK		SHEET: 1/4	REV. REF
UNIT: mm	SCALE: A4 1:1	CHECKED:	
THIRD ANGLE PROJECTION		APPROVED:	
TOLERANCE: Angle: ± 1°		MATERIAL: RoHS Compliant	DATE: 03/25/2024
X ± 0.25 .X ± 0.20 .XX ± 0.15		DRAWN: Gary	

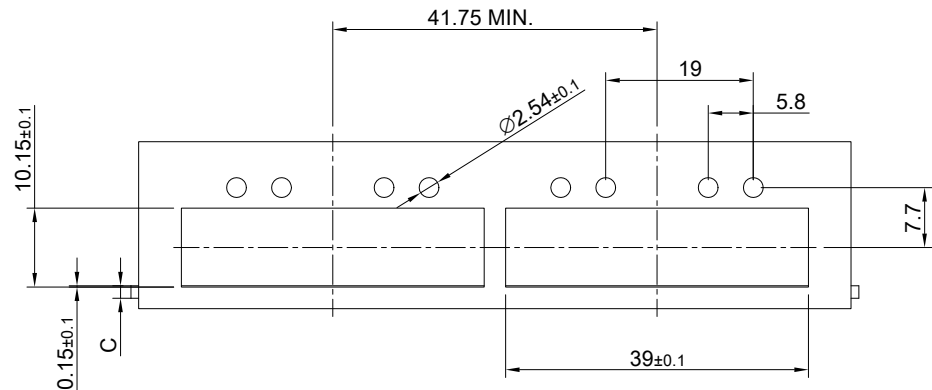

SINGLE-SIDE CONFIGURATION

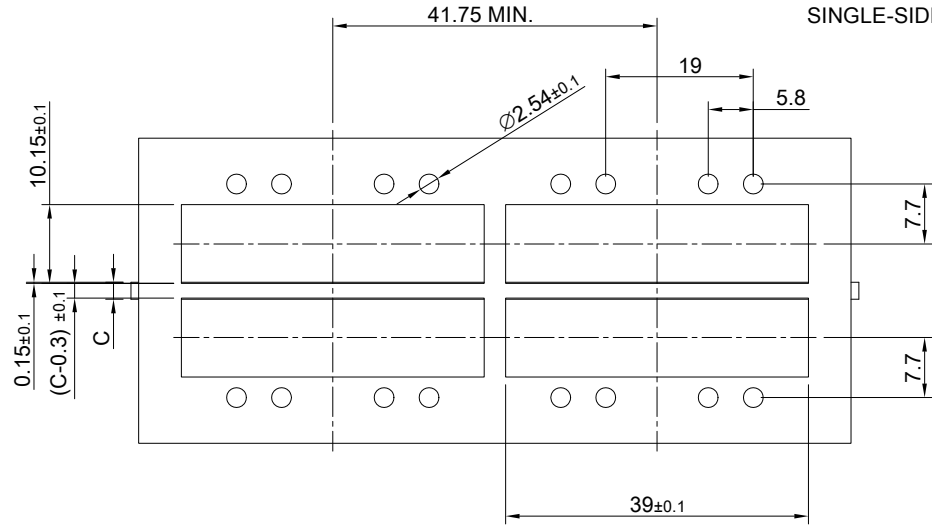

BELLY TO BELLY CONFIGURATION

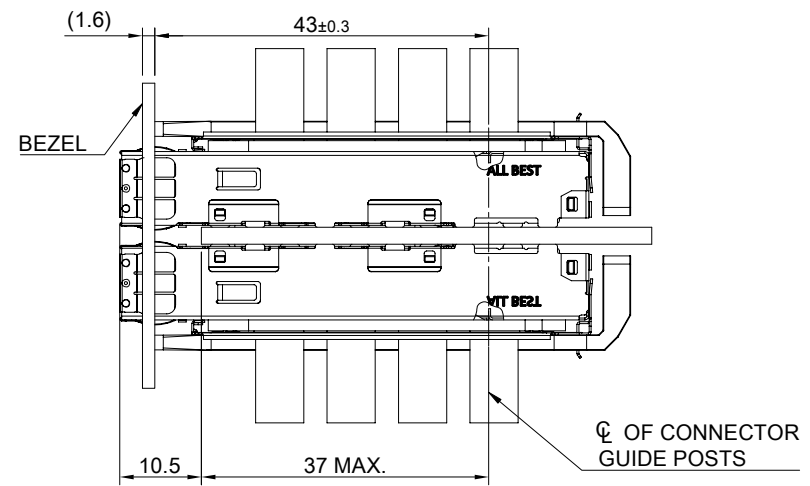
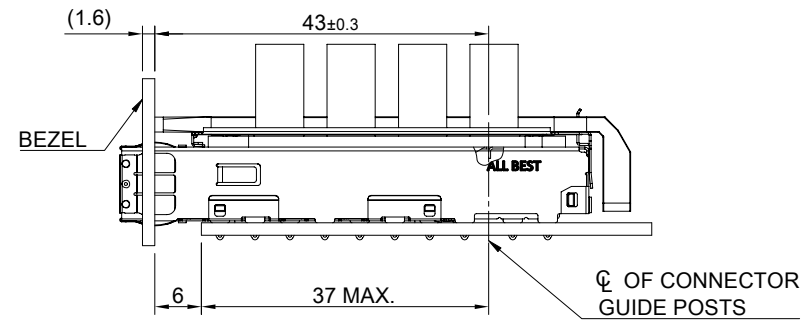

C = THICKNESS OF PC BOARD
 SINGLE-SIDE = 1.6MM (MIN.)
 BELLY TO BELLY = 2.2MM (MIN.)

THIS PRINT IS
PRELIMINARY
 UNQUALIFIED PRODUCT
 CONTACT PRODUCT ENGINEERING
 BEFORE USING THIS PRINT



TITLE: QSFP28 1X2 Cage w/ Light Pipe & NET Heat Sink			
DWG#: R-OR-ZQ2-4CMED-MK		SHEET: 2/4	REV. REF
UNIT: mm	SCALE: A4 1:1	CHECKED:	
TOLERANCE: Angle: ± 1° X ± 0.15 .X ± 0.10 .XX ± 0.05		MATERIAL: RoHS Compliant	APPROVED:
THIRD ANGLE PROJECTION		DRAWN: Gary	DATE: 03/25/2024

A B C D E F G H

1 1

2 2

3 3

4 4

5 5

6 6

7 7

8 8

DUAL LIGHT PIPE
LED LAYOUT

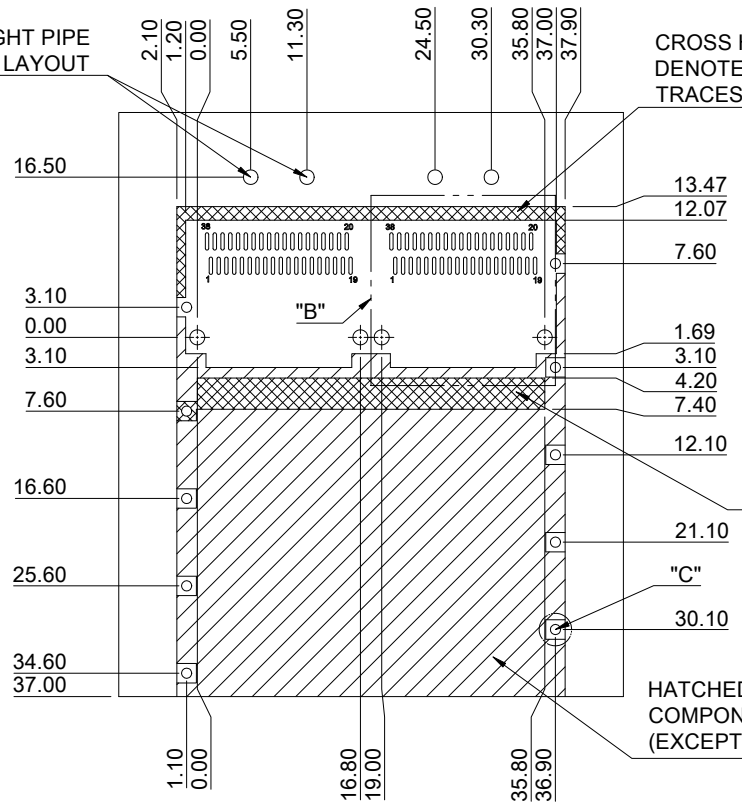

CROSS HATCHED AREA
DENOTES WHERE SURFACE
TRACES ARE PERMITTED

AREA DENOTES COMPONENT
KEEP-OUT (TRACES ALLOWED)

CROSS HATCHED AREA
DENOTES EMI GROUNDING
PAD (MUST BE CONNECTED
TO CHASSIS GROUND)

HATCHED AREA DENOTES
COMPONENT AND TRACE KEEP-OUT
(EXCEPT CHASSIS GROUND)

PCB LAYOUT FOR SINGLE-SIDE CONFIGURATION
TOLERANCE: ± 0.05
MINIMUM PCB THICKNESS OF 1.6 MM

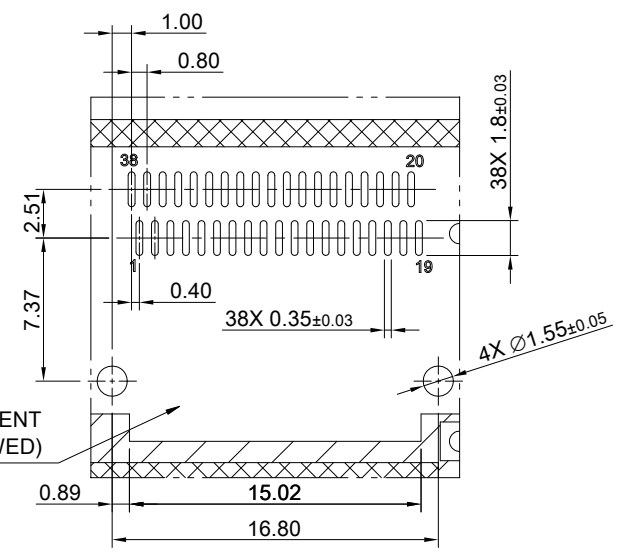

DETAIL B
SCALE 2:1

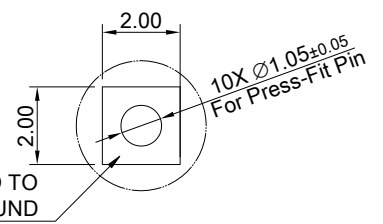

PADS AND VIAS GO TO
CHASSIS GROUND

DETAIL C
SCALE 4:1

THIS PRINT IS
PRELIMINARY
UNQUALIFIED PRODUCT
CONTACT PRODUCT ENGINEERING
BEFORE USING THIS PRINT



TITLE: QSFP28 1X2 Cage w/ Light Pipe & NET Heat Sink			
DWG#: R-OR-ZQ2-4CMED-MK		SHEET: 3/4	REV. REF
UNIT: mm	SCALE: A4 5:4	CHECKED:	
THIRD ANGLE PROJECTION		APPROVED:	
TOLERANCE: Angle: $\pm 1^\circ$ X: ± 0.15 .X: ± 0.10 .XX: ± 0.05		MATERIAL: RoHS Compliant	DATE: 03/25/2024
		DRAWN: Gary	

A B C D E F G H

A B C D E F G H

1 1

2 2

3 3

4 4

5 5

6 6

7 7

8 8

DUAL LIGHT PIPE
LED LAYOUT

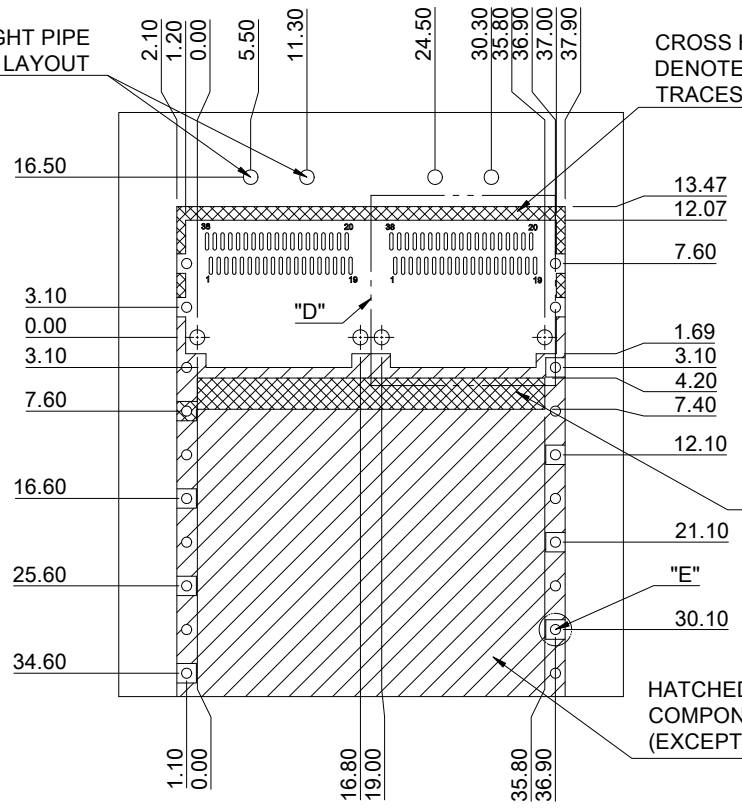

CROSS HATCHED AREA
DENOTES WHERE SURFACE
TRACES ARE PERMITTED

AREA DENOTES COMPONENT
KEEP-OUT (TRACES ALLOWED)

CROSS HATCHED AREA
DENOTES EMI GROUNDING
PAD (MUST BE CONNECTED
TO CHASSIS GROUND)

HATCHED AREA DENOTES
COMPONENT AND TRACE KEEP-OUT
(EXCEPT CHASSIS GROUND)

PCB LAYOUT FOR BELLY TO BELLY CONFIGURATION
TOLERANCE: ± 0.05
MINIMUM PCB THICKNESS OF 2.2 MM

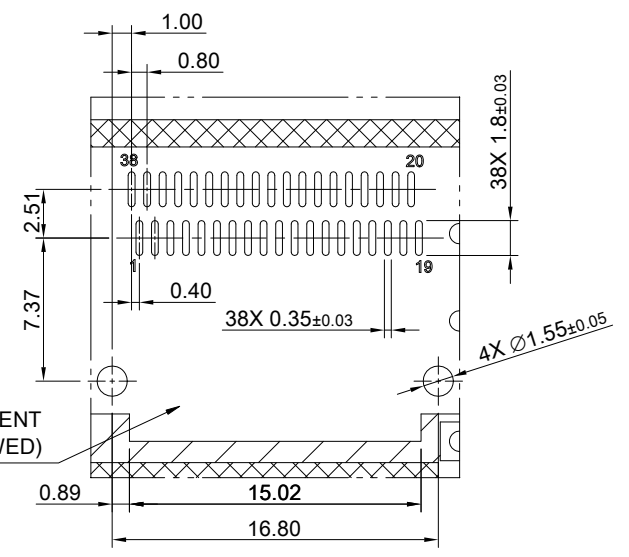

DETAIL D
SCALE 2:1

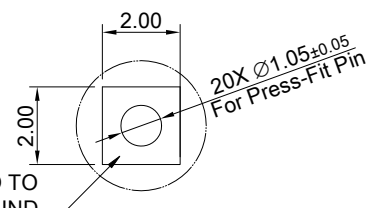

PADS AND VIAS GO TO
CHASSIS GROUND

DETAIL E
SCALE 4:1

THIS PRINT IS
PRELIMINARY
UNQUALIFIED PRODUCT
CONTACT PRODUCT ENGINEERING
BEFORE USING THIS PRINT



TITLE: QSFP28 1X2 Cage w/ Light Pipe & NET Heat Sink			
DWG#: R-OR-ZQ2-4CMED-MK		SHEET: 4/4	REV. REF
UNIT: mm	SCALE: A4 5:4	CHECKED:	
THIRD ANGLE PROJECTION		APPROVED:	
TOLERANCE: Angle: $\pm 1^\circ$ X: ± 0.15 .X: ± 0.10 .XX: ± 0.05		DATE: 03/25/2024	
FINISH:		MATERIAL: RoHS Compliant	
DRAWN: Gary			

A B C D E F G H