

THIS PRINT IS
PRELIMINARY
UNQUALIFIED PRODUCT
CONTACT PRODUCT ENGINEERING
BEFORE USING THIS PRINT

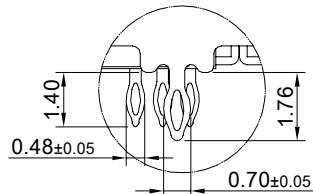

DETAIL B
SCALE 5:1

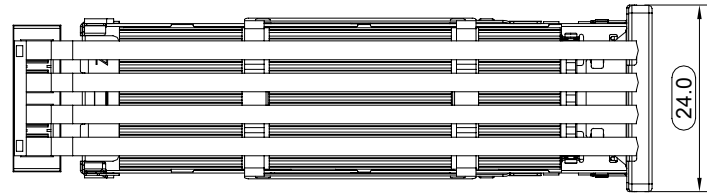
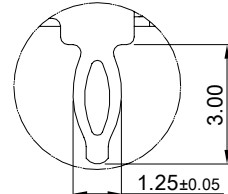

DETAIL A
SCALE 5:1

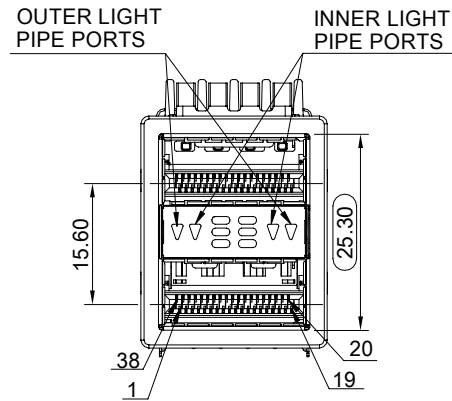
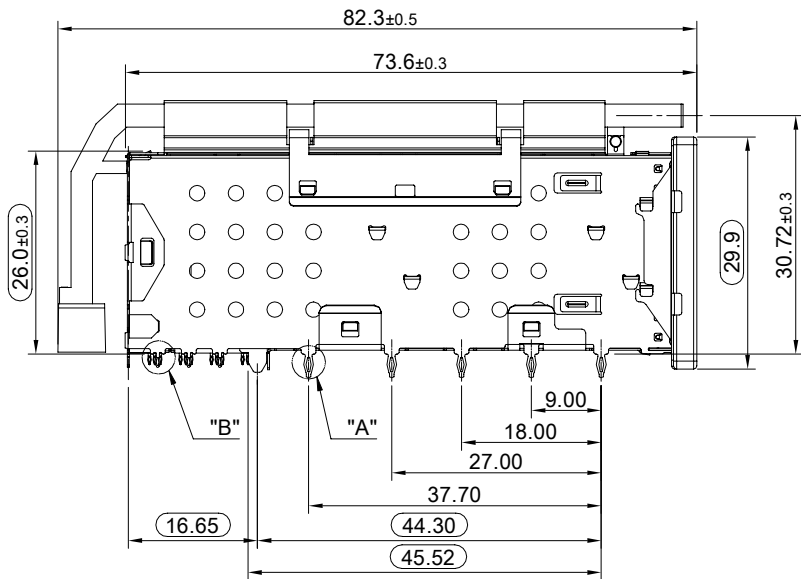
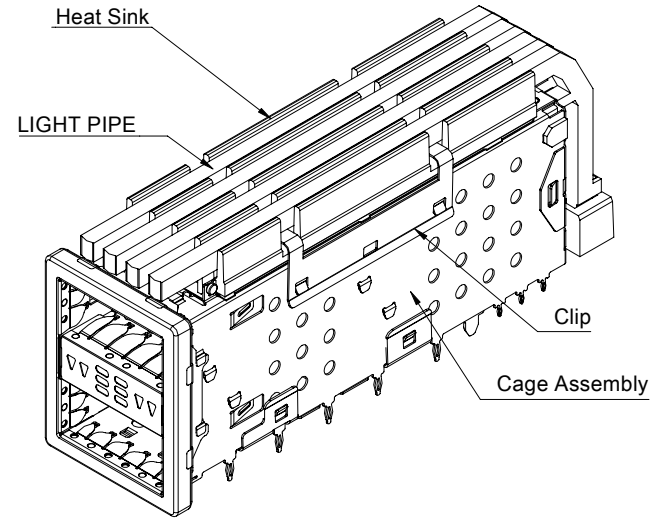

MATERIAL
 CAGE: NICKEL SILVER
 CONNECTOR HOUSING: THERMOPLASTIC, UL 94V-0(LCP)
 INSULATOR COLOR: DEEP GRAY
 EMI SPRING: STAINLESS STEEL
 CONTACTS: COPPER ALLOY
 EMI GASKET FLANGE: STAINLESS STEEL
 EMI GASKET: CONDUCTIVE ELASTOMER(UGTP)
 HEAT SINK: ALUMINUM
 HEAT SINK CLIP: STAINLESS STEEL
 LIGHT PIPE: PC
 LIGHT SHIELD: THERMOPLASTIC

FINISH
 HEAT SINK: ANODE PROCESS
 CONTACT: 15μ" MIN. GOLD ON MATING END;
 30μ" MIN. MATTE TIN ON TERMINAL END;
 ALL UNDERPLATED 50μ" MIN. NICKEL

ELECTRICAL CHARACTERISTICS
 CONTACT CURRENT RATING: 0.5AMPERE
 VOLTAGE RATING: 30VAC
 CONTACT RESISTANCE: 80 mΩ MAX.
 DIELECTRIC WITHSTANDING VOLTAGE: 300VAC

 ALL BEST ALL BEST ELECTRONICS CO., LTD.	TITLE: Stacked QSFP56 2x1 Assembly w/ Internal / External Heat Sink & Light Pipe		SHEET:	REV.
	DWG#: R-TR-DZQT1-4CGNLI-AIO-4		1/3	REF
	UNIT: mm	SCALE: A4 1:1	FINISH:	CHECKED:
	TOLERANCE: Angle: ± 1° X.±0.25 .X±0.20 .XX±0.15		MATERIAL: RoHS Compliant	APPROVED:
		DRAWN: Yilu	DATE:	03/20/2024

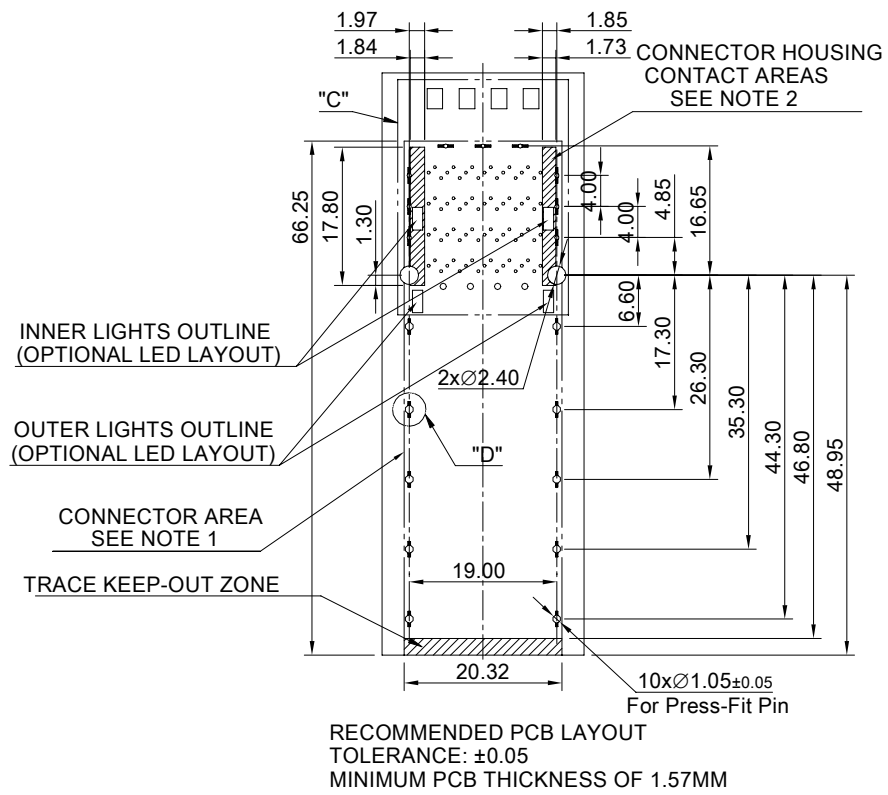

TRACE KEEP-OUT ZONE
AROUND PRESS-FIT TAIL HOLES

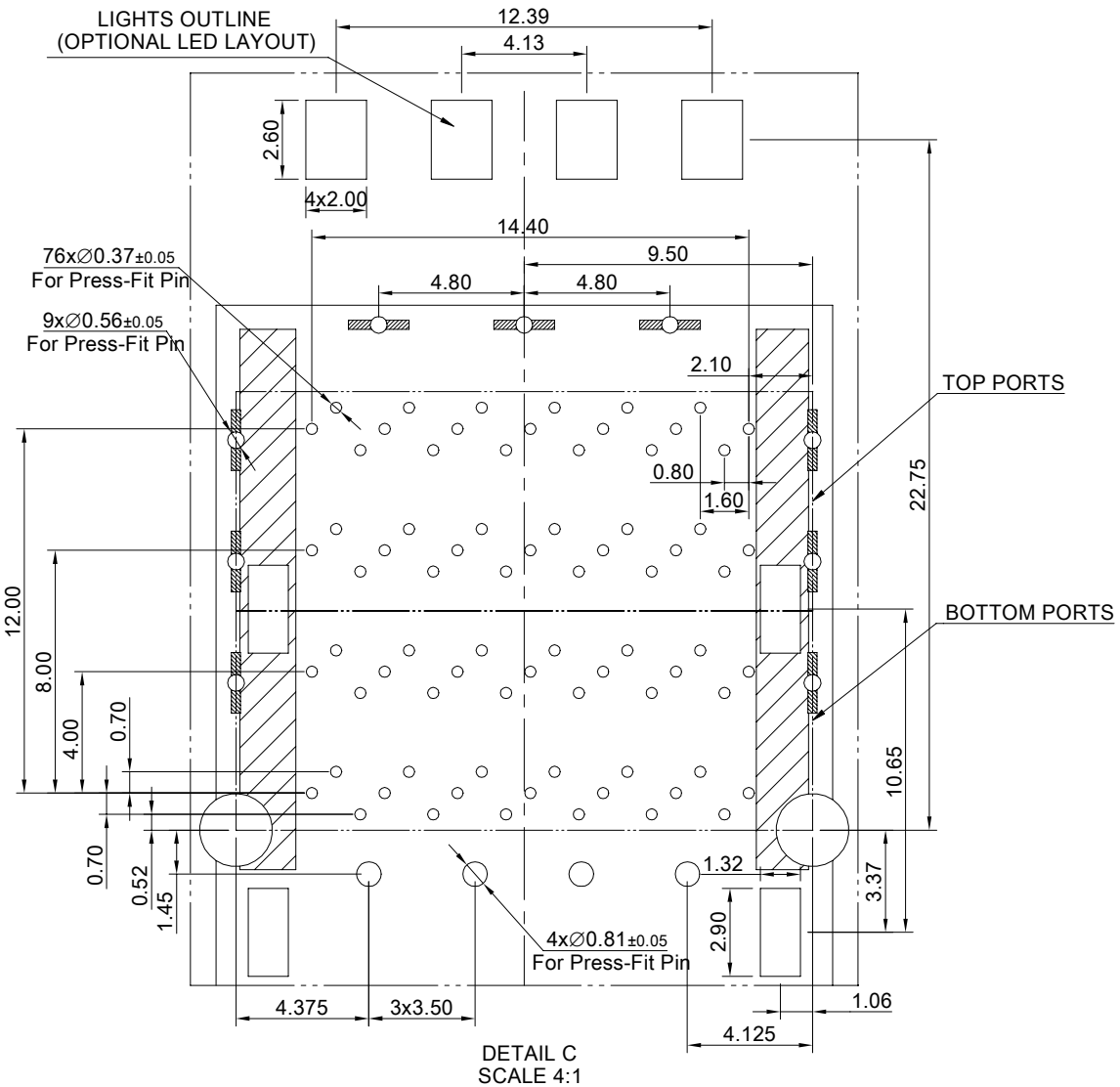
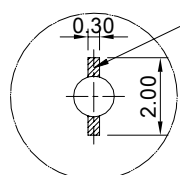

THIS PRINT IS
PRELIMINARY
UNQUALIFIED PRODUCT
CONTACT PRODUCT ENGINEERING
BEFORE USING THIS PRINT



TITLE: Stacked QSFP56 2x1 Assembly w/ Internal / External Heat Sink & Light Pipe		SHEET:	REV.
DWG#: R-TR-DZQT1-4CGNLI-AIO-4		2/3	REF
UNIT:	SCALE:	FINISH:	
mm	A4 1:1	CHECKED:	
TOLERANCE: Angle: $\pm 1^\circ$ X: ± 0.15 .X: ± 0.1 .XX: ± 0.05		APPROVED:	
THIRD ANGLE PROJECTION		MATERIAL: RoHS Compliant	
DRAWN: Yilu		DATE: 03/20/2024	

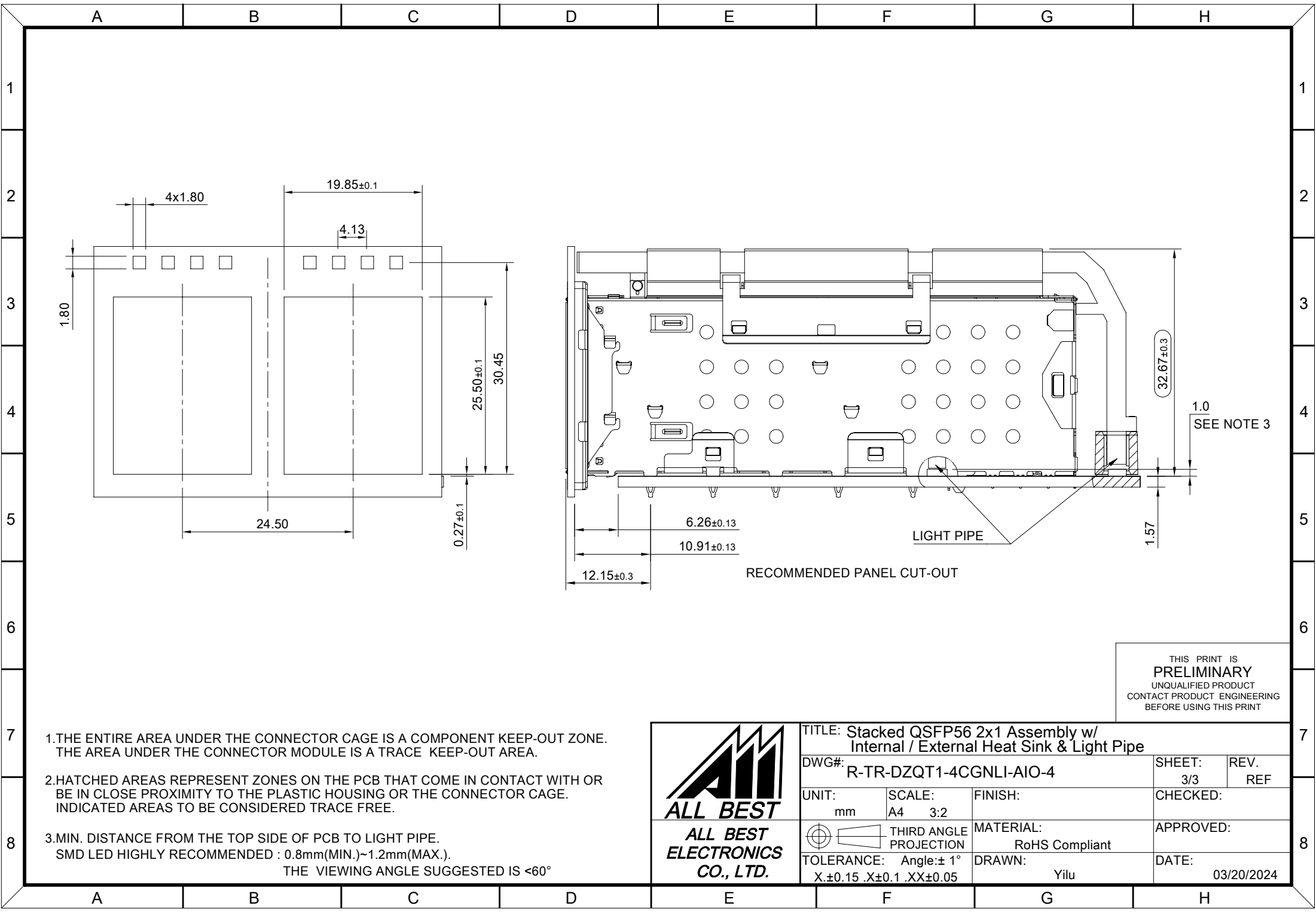

THIS PRINT IS
PRELIMINARY
 UNQUALIFIED PRODUCT
 CONTACT PRODUCT ENGINEERING
 BEFORE USING THIS PRINT

1. THE ENTIRE AREA UNDER THE CONNECTOR CAGE IS A COMPONENT KEEP-OUT ZONE.
 THE AREA UNDER THE CONNECTOR MODULE IS A TRACE KEEP-OUT AREA.
2. HATCHED AREAS REPRESENT ZONES ON THE PCB THAT COME IN CONTACT WITH OR
 BE IN CLOSE PROXIMITY TO THE PLASTIC HOUSING OR THE CONNECTOR CAGE.
 INDICATED AREAS TO BE CONSIDERED TRACE FREE.
3. MIN. DISTANCE FROM THE TOP SIDE OF PCB TO LIGHT PIPE.
 SMD LED HIGHLY RECOMMENDED : 0.8mm(MIN.)~1.2mm(MAX.).
 THE VIEWING ANGLE SUGGESTED IS <60°



TITLE: Stacked QSFP56 2x1 Assembly w/ Internal / External Heat Sink & Light Pipe			
DWG#: R-TR-DZQT1-4CGNLI-AIO-4		SHEET: 3/3	REV. REF
UNIT: mm	SCALE: A4 3:2	FINISH:	CHECKED:
THIRD ANGLE PROJECTION		MATERIAL: RoHS Compliant	APPROVED:
TOLERANCE: Angle: ± 1° X.±0.15 .X±0.1 .XX±0.05		DRAWN: Yilu	DATE: 03/20/2024