

DETAIL A
SCALE 4:1

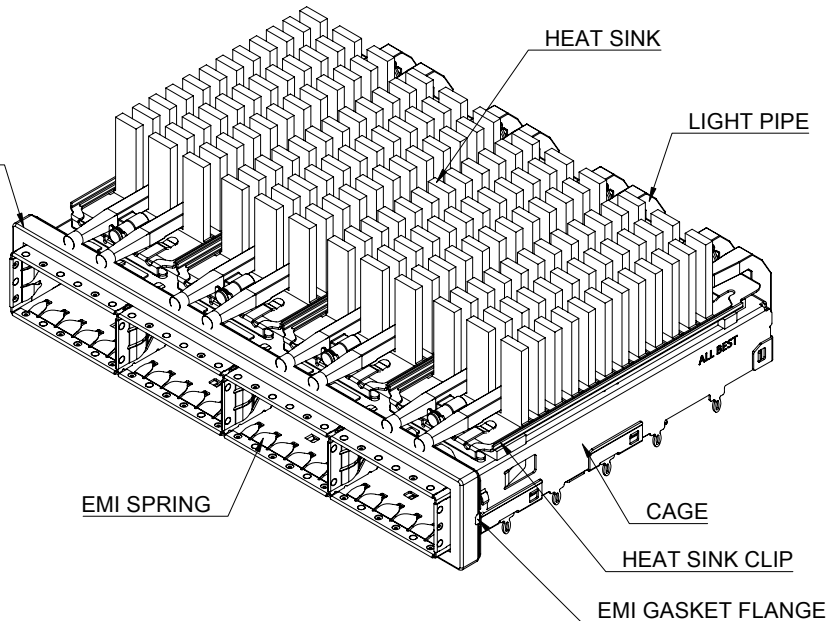

- MATERIAL
 CAGE: NICKEL SILVER
 HEAT SINK: ALUMINUM
 HEAT SINK CLIP: STAINLESS STEEL
 EMI SPRING: STAINLESS STEEL
 EMI GASKET: CONDUCTIVE ELASTOMER
 EMI GASKET FLANGE: STAINLESS STEEL
 LIGHT PIPE: PC

- FINISH
 HEAT SINK: ANODE PROCESS

NOTE
 ⚠ DIMENSION APPLIES WITH MODULE INSERTED IN CAGE

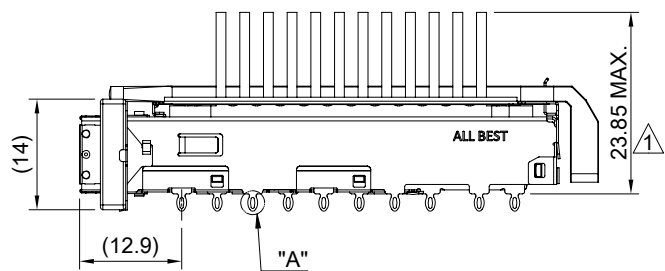

THIS PRINT IS
PRELIMINARY
 UNQUALIFIED PRODUCT
 CONTACT PRODUCT ENGINEERING
 BEFORE USING THIS PRINT



TITLE: QSFP56 1X4 Cage Assembly w/ Light Pipe & NET Heat Sink			SHEET: 1/4	REV. REF
DWG#: R-OR-DZQ4-4CGE3-MK			CHECKED:	
UNIT: mm	SCALE: A4 1:1	FINISH:		APPROVED:
TOLERANCE: Angle: ± 1° X ± 0.25 .X ± 0.20 .XX ± 0.15		MATERIAL: RoHS Compliant		DATE: 3/14/2024
THIRD ANGLE PROJECTION		DRAWN: Pohsiung		

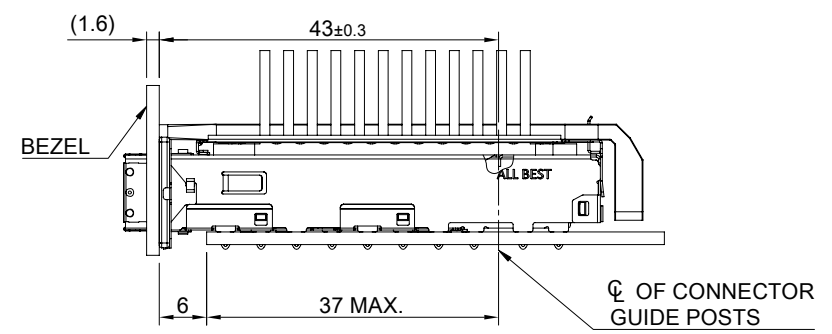
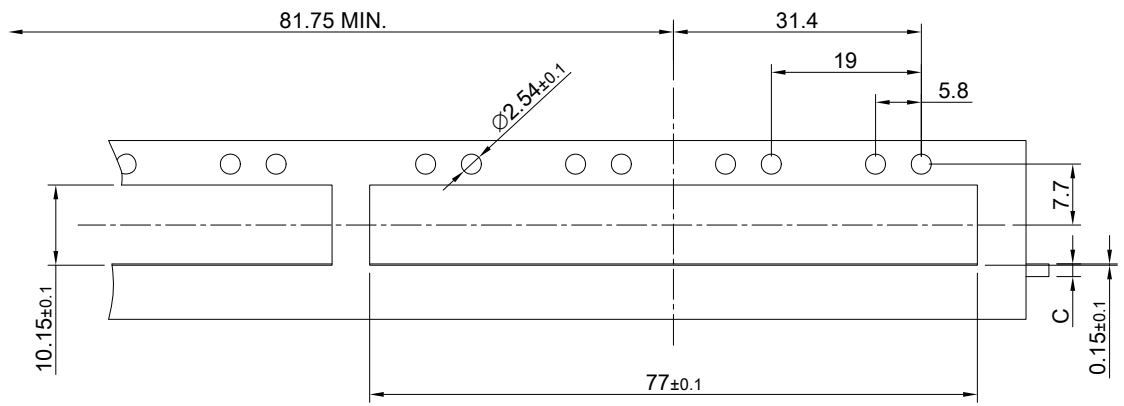

SINGLE-SIDE CONFIGURATION

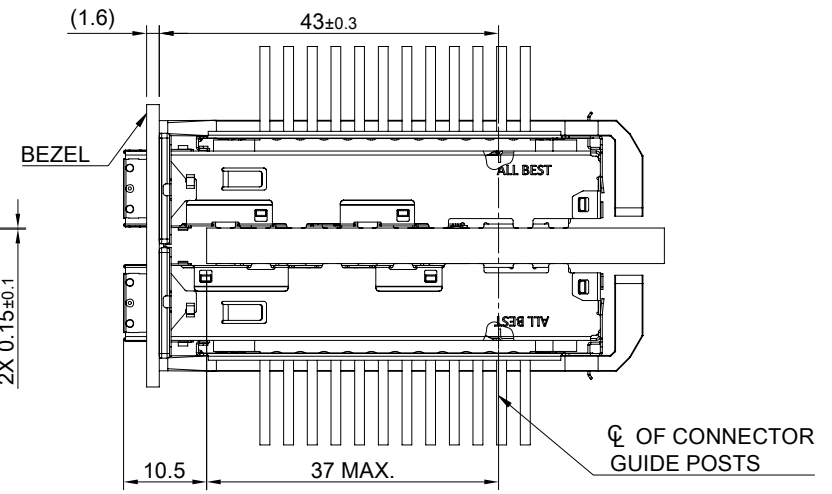
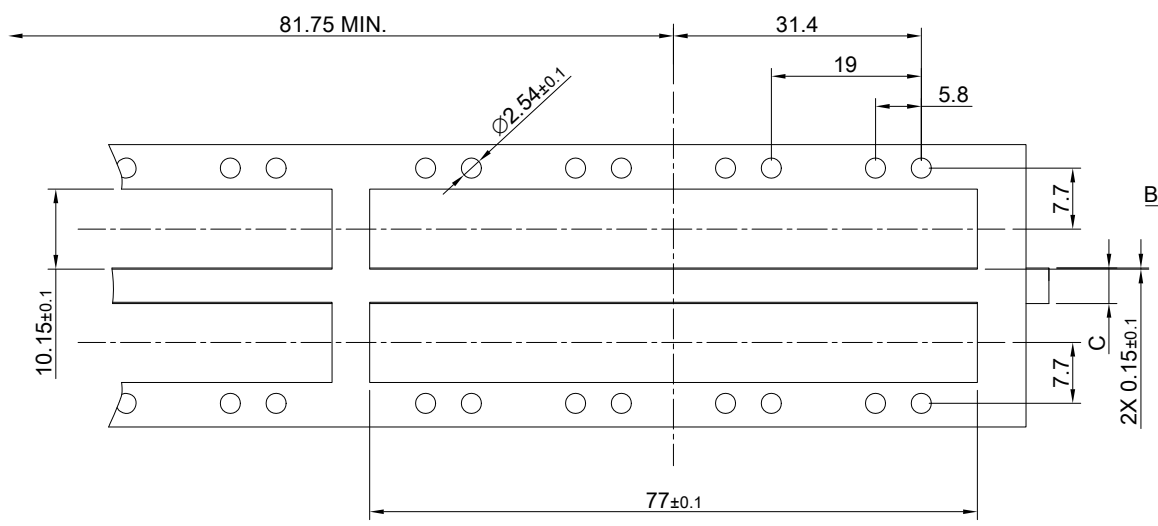

BELLY TO BELLY CONFIGURATION

C = THICKNESS OF PC BOARD
 SINGLE-SIDE = 1.6MM (MIN.)
 BELLY TO BELLY = 4.5MM (MIN.)

THIS PRINT IS
PRELIMINARY
 UNQUALIFIED PRODUCT
 CONTACT PRODUCT ENGINEERING
 BEFORE USING THIS PRINT



TITLE: QSFP56 1X4 Cage Assembly w/ Light Pipe & NET Heat Sink			SHEET: 2/4	REV. REF
DWG#: R-OR-DZQ4-4CGE3-MK			CHECKED:	
UNIT: mm	SCALE: A4 1:1	FINISH:		APPROVED:
THIRD ANGLE PROJECTION		MATERIAL: RoHS Compliant		DATE: 3/14/2024
TOLERANCE: Angle: ± 1° X ± 0.15 .X ± 0.10 .XX ± 0.05		DRAWN: Pohsiung		

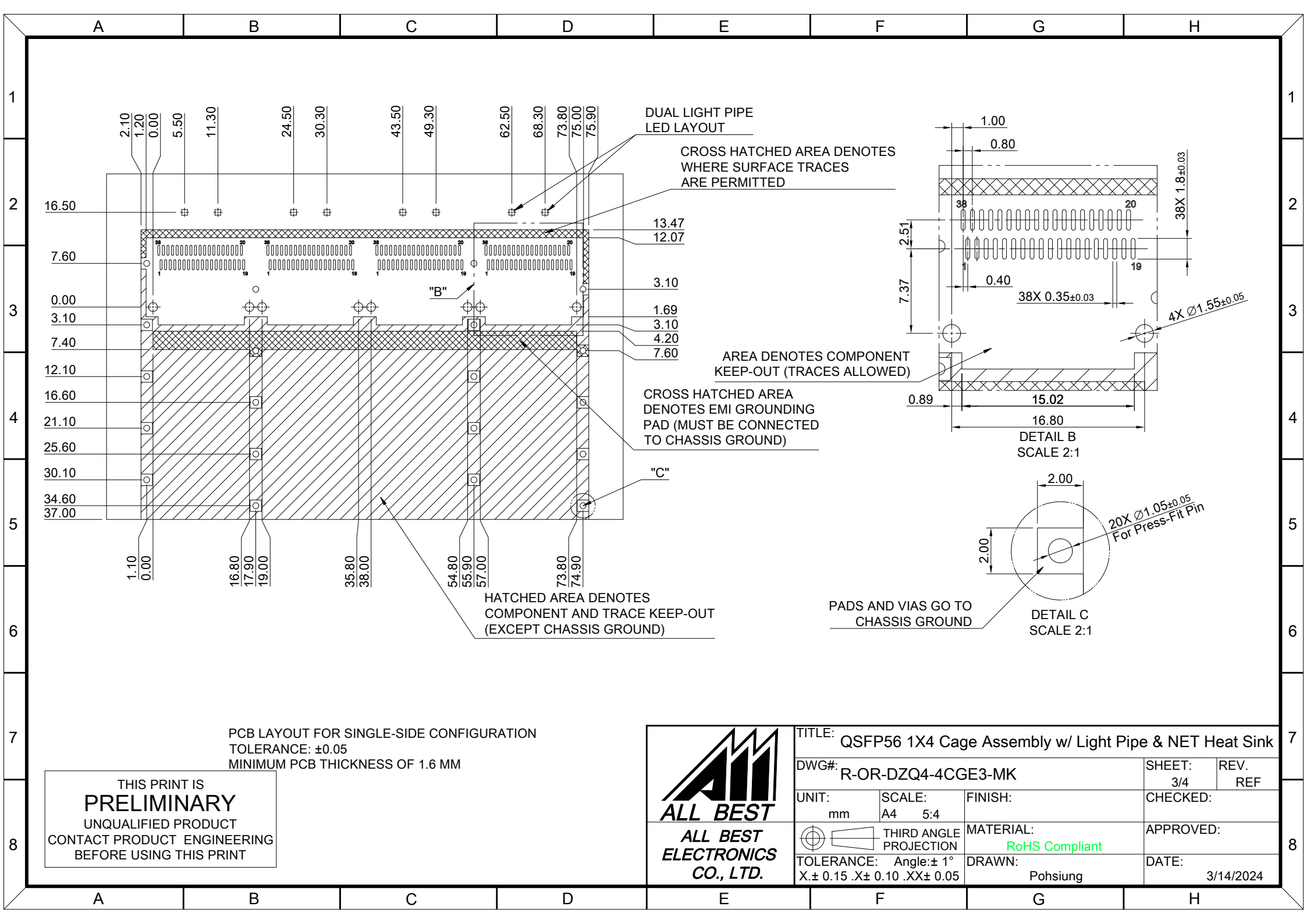

DUAL LIGHT PIPE LED LAYOUT
 CROSS HATCHED AREA DENOTES WHERE SURFACE TRACES ARE PERMITTED

AREA DENOTES COMPONENT KEEP-OUT (TRACES ALLOWED)

CROSS HATCHED AREA DENOTES EMI GROUNDING PAD (MUST BE CONNECTED TO CHASSIS GROUND)

HATCHED AREA DENOTES COMPONENT AND TRACE KEEP-OUT (EXCEPT CHASSIS GROUND)



PADS AND VIAS GO TO CHASSIS GROUND

DETAIL B
SCALE 2:1

DETAIL C
SCALE 2:1

PCB LAYOUT FOR SINGLE-SIDE CONFIGURATION
 TOLERANCE: ±0.05
 MINIMUM PCB THICKNESS OF 1.6 MM

THIS PRINT IS
PRELIMINARY
 UNQUALIFIED PRODUCT
 CONTACT PRODUCT ENGINEERING
 BEFORE USING THIS PRINT

 ALL BEST ELECTRONICS CO., LTD.		TITLE: QSFP56 1X4 Cage Assembly w/ Light Pipe & NET Heat Sink	
		DWG#: R-OR-DZQ4-4CGE3-MK	SHEET: 3/4 REV. REF
UNIT: mm	SCALE: A4 5:4	FINISH:	CHECKED:
 THIRD ANGLE PROJECTION		MATERIAL: RoHS Compliant	APPROVED:
TOLERANCE: Angle: ± 1° X. ± 0.15 .X ± 0.10 .XX ± 0.05		DRAWN: Pohsiung	DATE: 3/14/2024

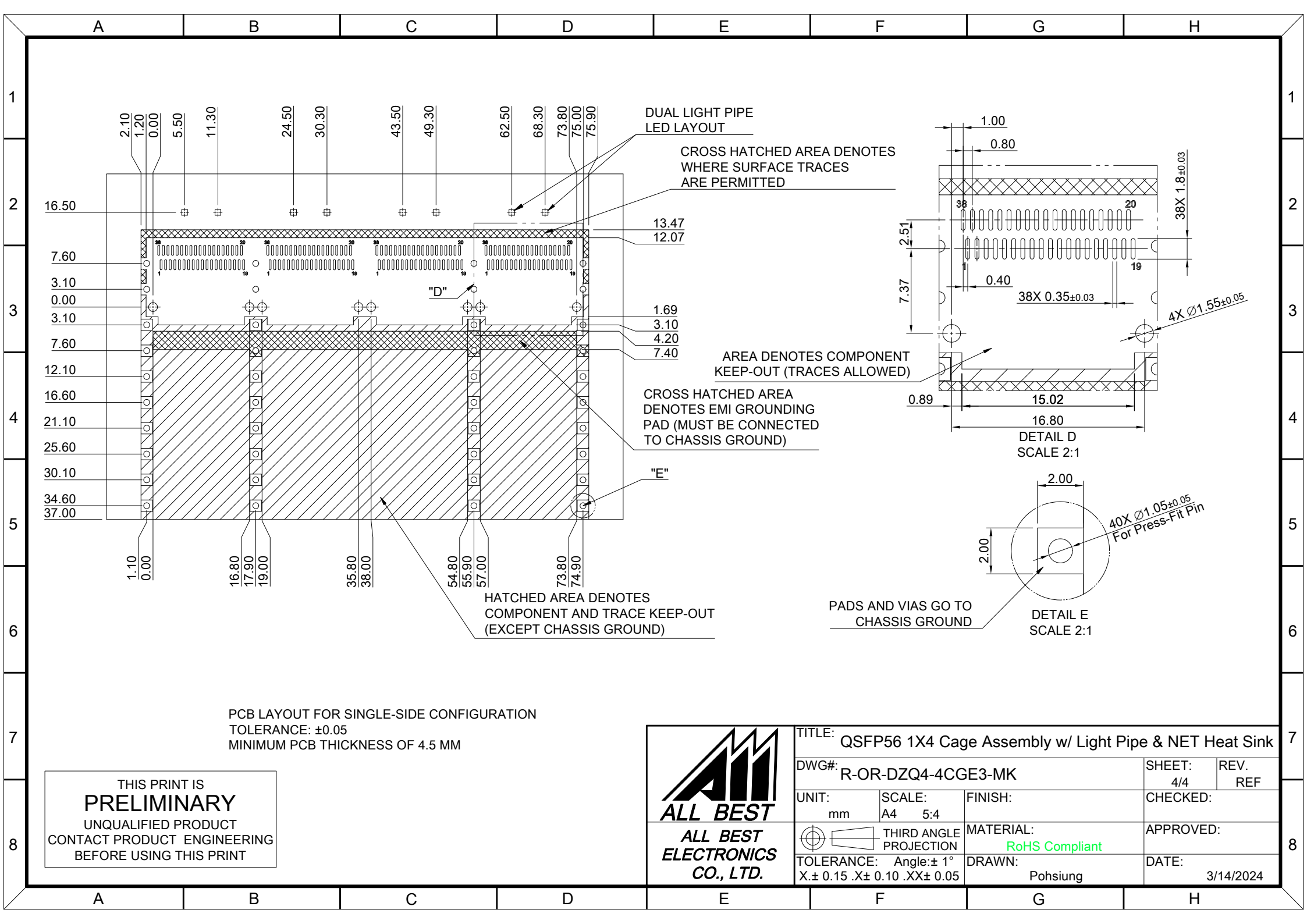

PCB LAYOUT FOR SINGLE-SIDE CONFIGURATION
 TOLERANCE: ±0.05
 MINIMUM PCB THICKNESS OF 4.5 MM

THIS PRINT IS
PRELIMINARY
 UNQUALIFIED PRODUCT
 CONTACT PRODUCT ENGINEERING
 BEFORE USING THIS PRINT



TITLE: QSFP56 1X4 Cage Assembly w/ Light Pipe & NET Heat Sink				
DWG#: R-OR-DZQ4-4CGE3-MK			SHEET: 4/4	REV. REF
UNIT: mm	SCALE: A4 5:4	FINISH:		CHECKED:
TOLERANCE: Angle: ± 1° X. ± 0.15 .X ± 0.10 .XX ± 0.05		MATERIAL: RoHS Compliant		APPROVED:
DRAWN: Pohsiung			DATE: 3/14/2024	

