

DETAIL A
SCALE 4:1

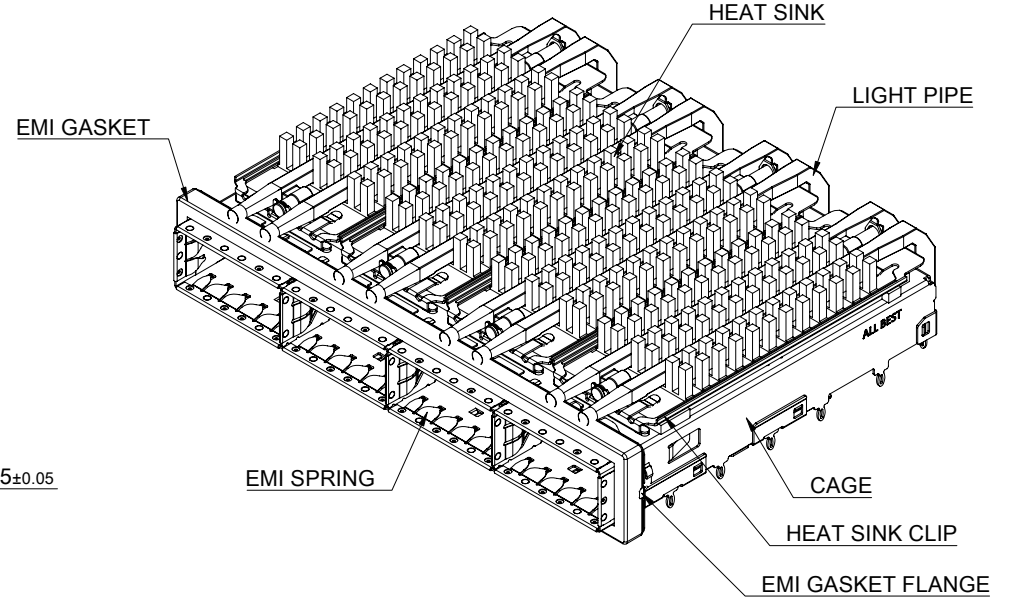
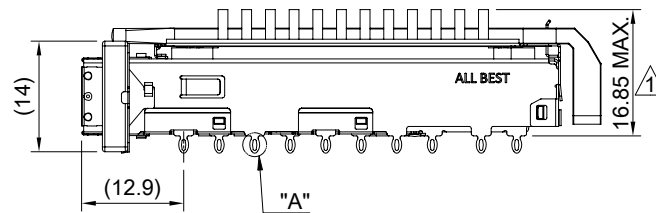

MATERIAL
 CAGE: NICKEL SILVER
 HEAT SINK: ALUMINUM
 HEAT SINK CLIP: STAINLESS STEEL
 EMI SPRING: STAINLESS STEEL
 EMI GASKET: CONDUCTIVE ELASTOMER
 EMI GASKET FLANGE: STAINLESS STEEL
 LIGHT PIPE: PC

FINISH
 HEAT SINK: ANODE PROCESS

NOTE
 ⚠ DIMENSION APPLIES WITH MODULE INSERTED IN CAGE

THIS PRINT IS
PRELIMINARY
 UNQUALIFIED PRODUCT
 CONTACT PRODUCT ENGINEERING
 BEFORE USING THIS PRINT



TITLE: QSFP56 1X4 Cage Assembly w/ Light Pipe & SAN Heat Sink			
DWG#: R-OR-DZQ4-4CGE4-MK		SHEET: 1/4	REV. REF
UNIT: mm	SCALE: A4 1:1	FINISH:	
TOLERANCE: Angle: ± 1° X ± 0.25 .X ± 0.20 .XX ± 0.15		MATERIAL: RoHS Compliant	APPROVED:
THIRD ANGLE PROJECTION		DRAWN: Pohsiung	DATE: 3/14/2024

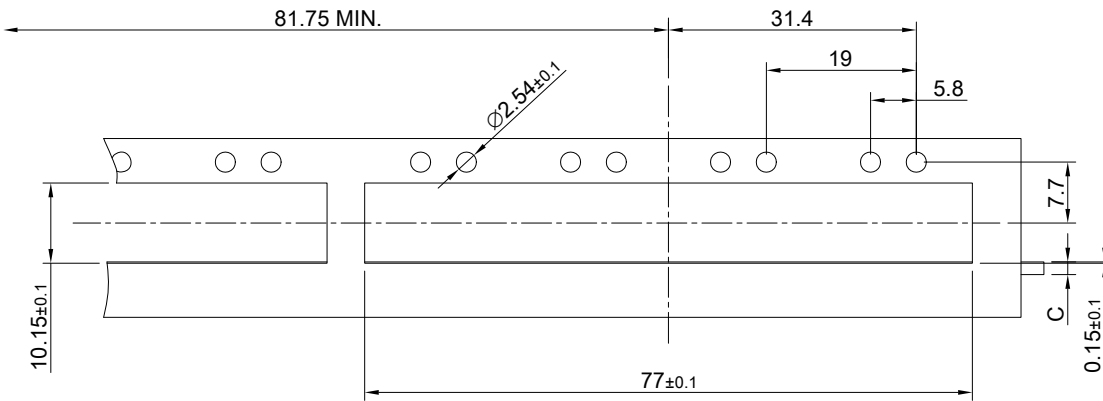

SINGLE-SIDE CONFIGURATION

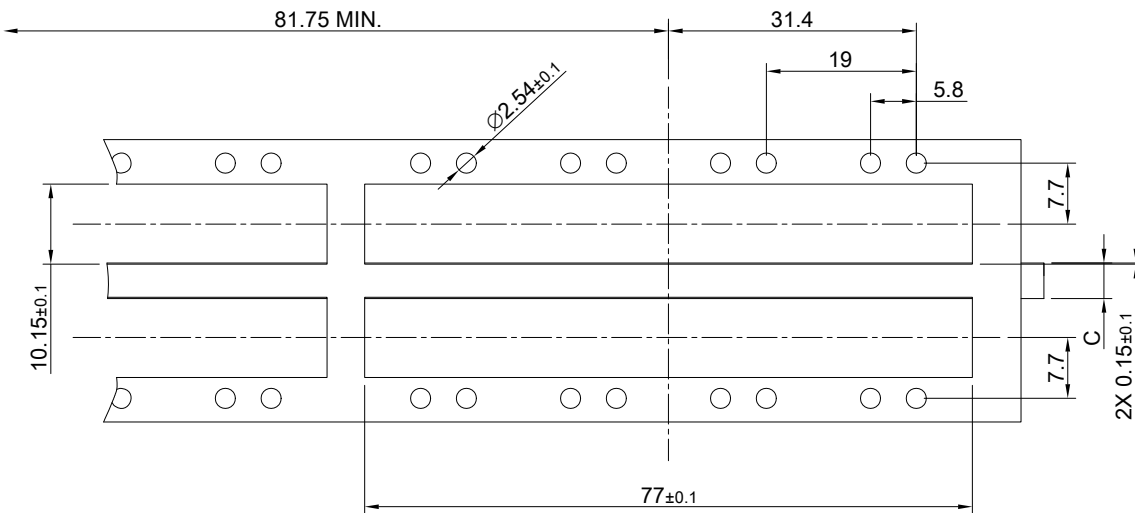
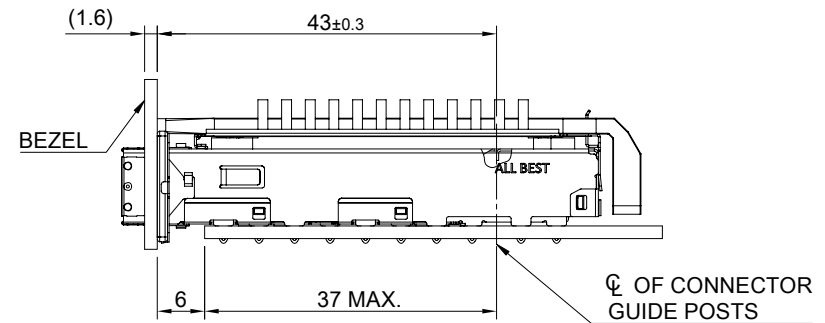

BELLY TO BELLY CONFIGURATION

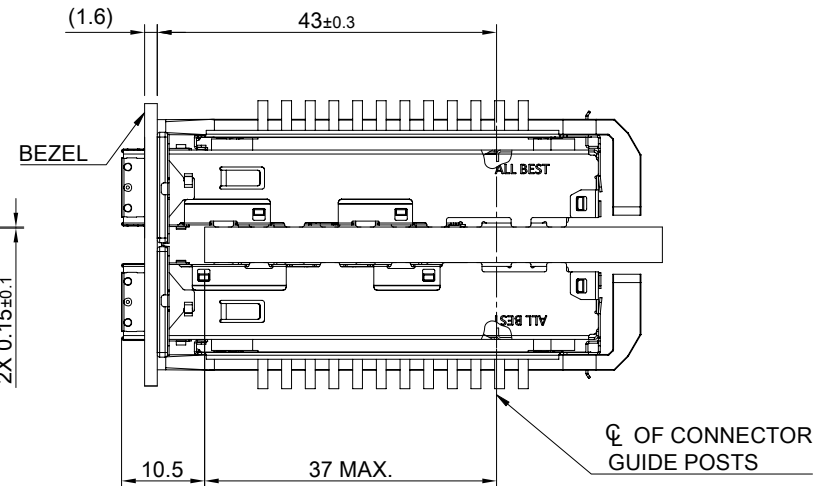

C = THICKNESS OF PC BOARD
 SINGLE-SIDE = 1.6MM (MIN.)
 BELLY TO BELLY = 4.5MM (MIN.)

THIS PRINT IS
PRELIMINARY
 UNQUALIFIED PRODUCT
 CONTACT PRODUCT ENGINEERING
 BEFORE USING THIS PRINT



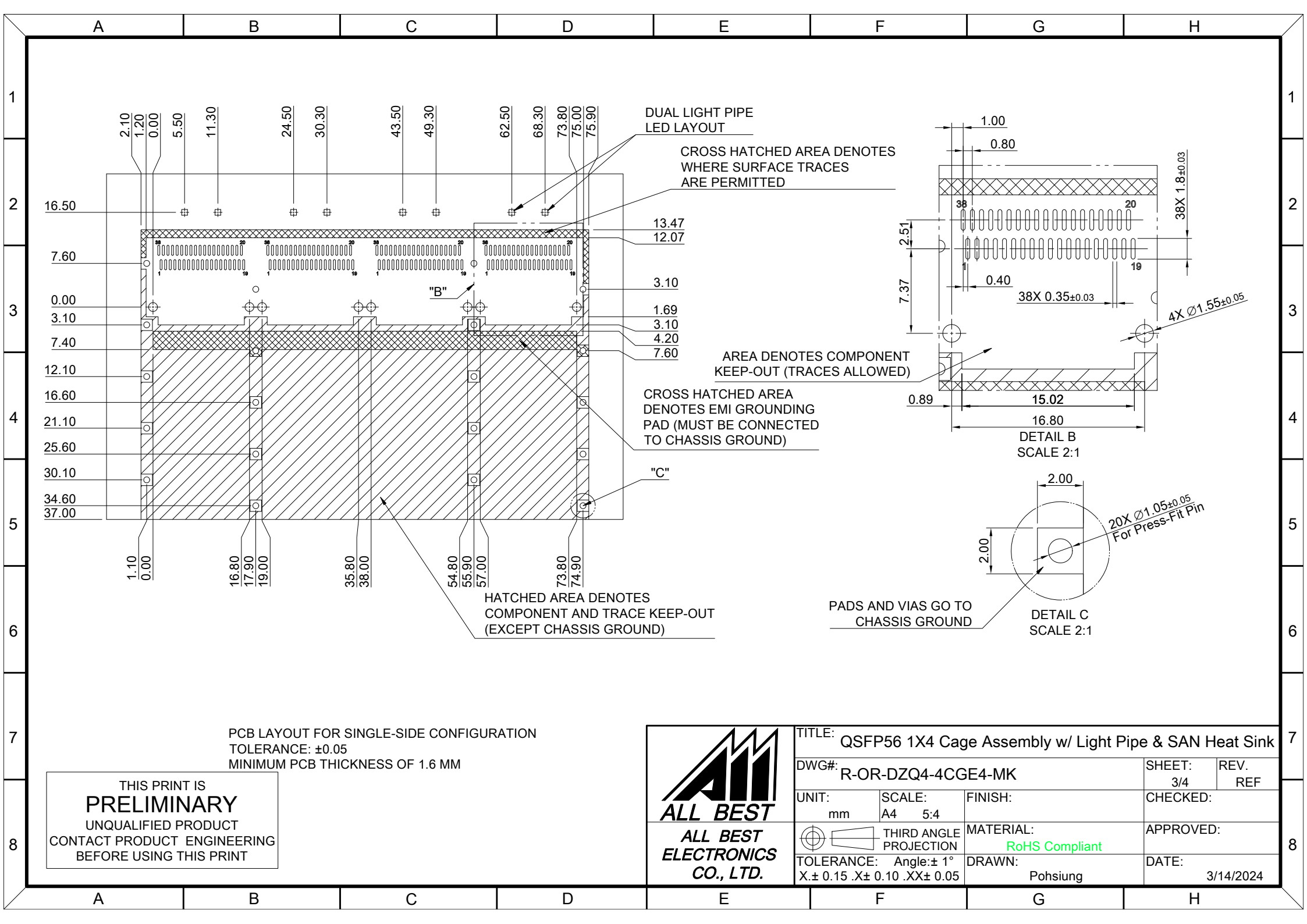

TITLE: QSFP56 1X4 Cage Assembly w/ Light Pipe & SAN Heat Sink				
DWG#: R-OR-DZQ4-4CGE4-MK			SHEET: 2/4	REV. REF
UNIT: mm	SCALE: A4 1:1	FINISH:		CHECKED:
TOLERANCE: Angle: ± 1° X ± 0.15 .X ± 0.10 .XX ± 0.05		MATERIAL: RoHS Compliant		APPROVED:
DRAWN: Pohsiung			DATE: 3/14/2024	



PCB LAYOUT FOR SINGLE-SIDE CONFIGURATION
 TOLERANCE: ± 0.05
 MINIMUM PCB THICKNESS OF 1.6 MM

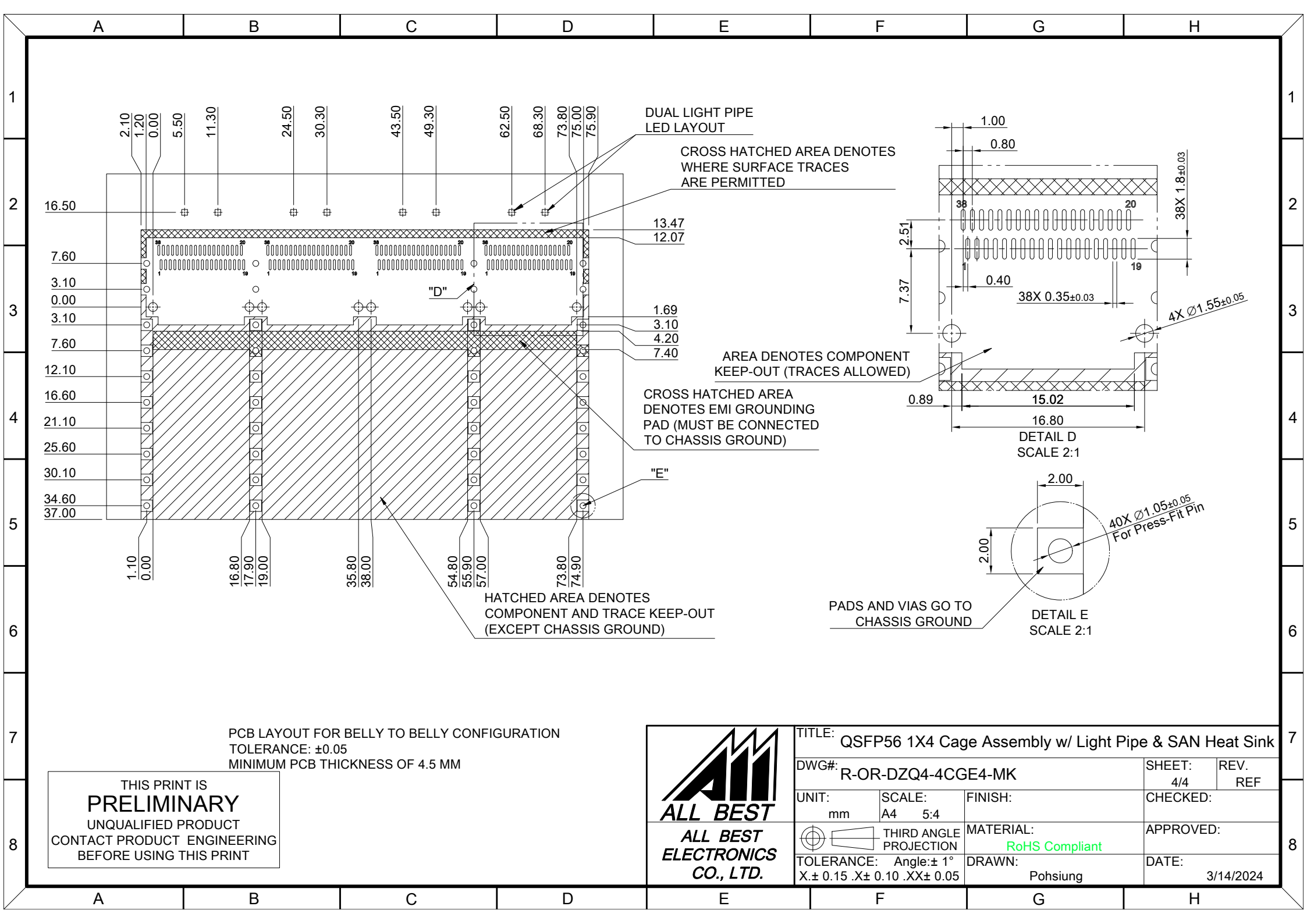

THIS PRINT IS
PRELIMINARY
 UNQUALIFIED PRODUCT
 CONTACT PRODUCT ENGINEERING
 BEFORE USING THIS PRINT

 ALL BEST ELECTRONICS CO., LTD.		TITLE: QSFP56 1X4 Cage Assembly w/ Light Pipe & SAN Heat Sink	
		DWG#: R-OR-DZQ4-4CGE4-MK	SHEET: 3/4 REV. REF
UNIT: mm	SCALE: A4 5:4	FINISH:	CHECKED:
 THIRD ANGLE PROJECTION		MATERIAL: RoHS Compliant	APPROVED:
TOLERANCE: Angle: $\pm 1^\circ$ X: ± 0.15 .X: ± 0.10 .XX: ± 0.05		DRAWN: Pohsiung	DATE: 3/14/2024



PCB LAYOUT FOR BELLY TO BELLY CONFIGURATION
 TOLERANCE: ± 0.05
 MINIMUM PCB THICKNESS OF 4.5 MM

THIS PRINT IS
PRELIMINARY
 UNQUALIFIED PRODUCT
 CONTACT PRODUCT ENGINEERING
 BEFORE USING THIS PRINT

 ALL BEST ELECTRONICS CO., LTD.		TITLE: QSFP56 1X4 Cage Assembly w/ Light Pipe & SAN Heat Sink	
		DWG#: R-OR-DZQ4-4CGE4-MK	SHEET: 4/4 REV. REF
UNIT: mm	SCALE: A4 5:4	FINISH:	CHECKED:
 THIRD ANGLE PROJECTION		MATERIAL: RoHS Compliant	APPROVED:
TOLERANCE: Angle: $\pm 1^\circ$ X: ± 0.15 .X: ± 0.10 .XX: ± 0.05		DRAWN: Pohsiung	DATE: 3/14/2024