

DETAIL A
SCALE 4:1

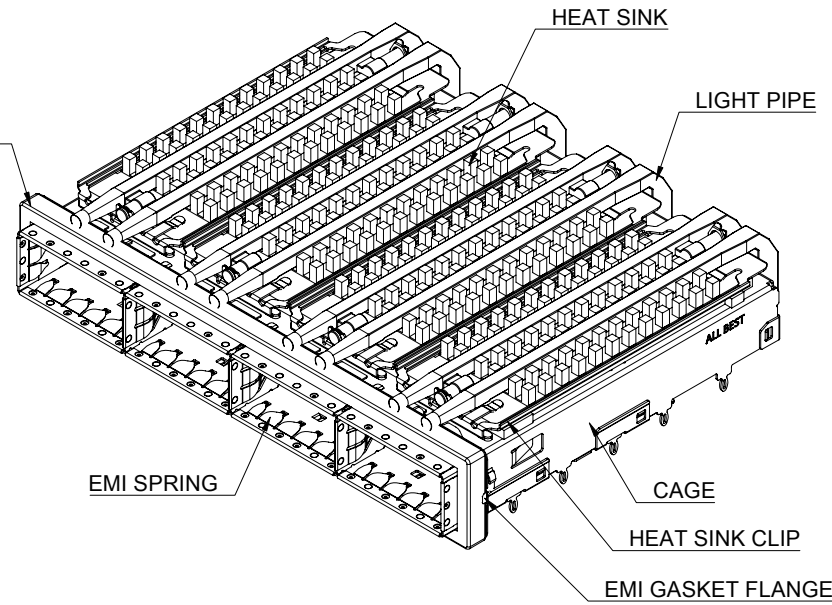
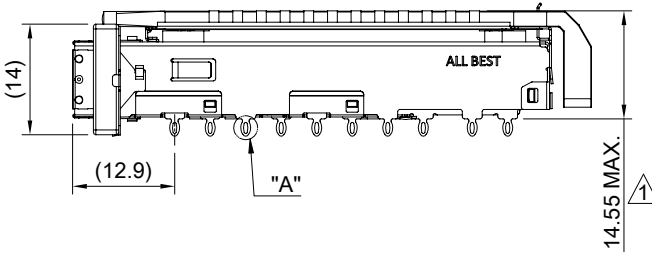

MATERIAL
 CAGE: NICKEL SILVER
 HEAT SINK: ALUMINUM
 HEAT SINK CLIP: STAINLESS STEEL
 EMI SPRING: STAINLESS STEEL
 EMI GASKET: CONDUCTIVE ELASTOMER
 EMI GASKET FLANGE: STAINLESS STEEL
 LIGHT PIPE: PC

FINISH
 HEAT SINK: ANODE PROCESS

NOTE
 ① DIMENSION APPLIES WITH MODULE INSERTED IN CAGE



TITLE: QSFP28 1X4 Cage Assembly w/ PCI Heat Sink & Light Pipe		SHEET: 1/4		REV. B	
DWG#: R-OR-ZQ4-4CGE5-MK		CHECKED:		APPROVED:	
UNIT: mm	SCALE: A4 1:1	FINISH:		DATE: 09/22/2021	
TOLERANCE: Angle: ± 1° X. ± 0.25 .X ± 0.20 .XX ± 0.15		MATERIAL: RoHS Compliant		DRAWN: Jason Zhao	

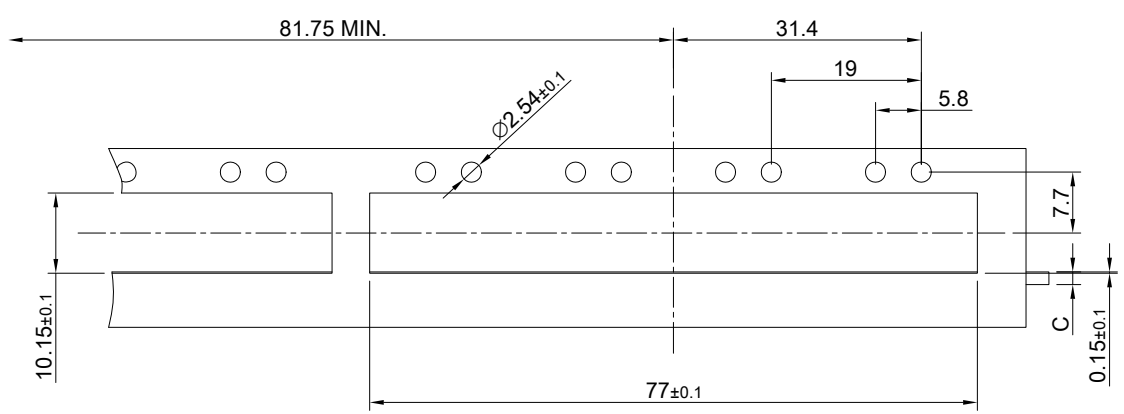

SINGLE-SIDE CONFIGURATION

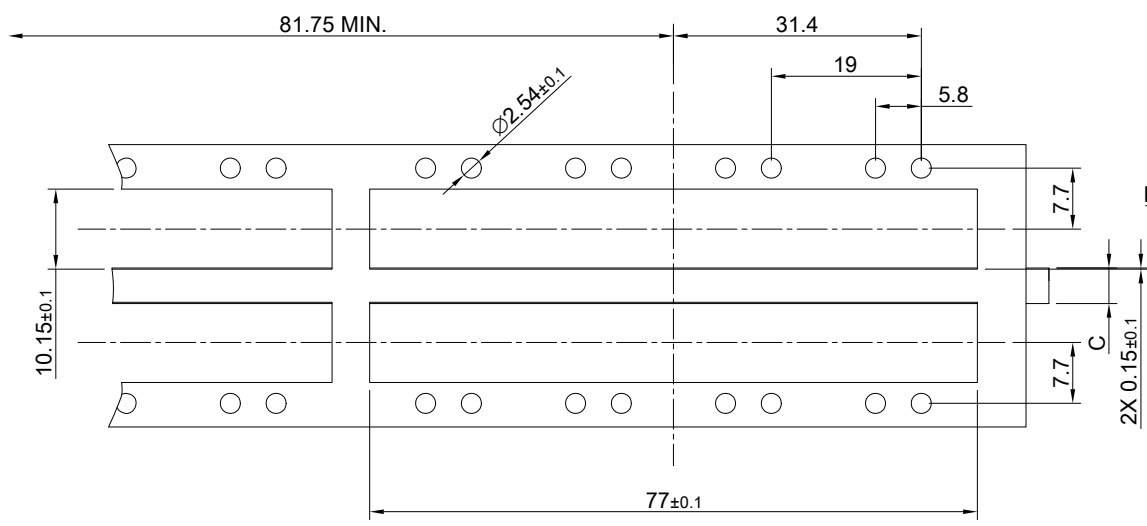
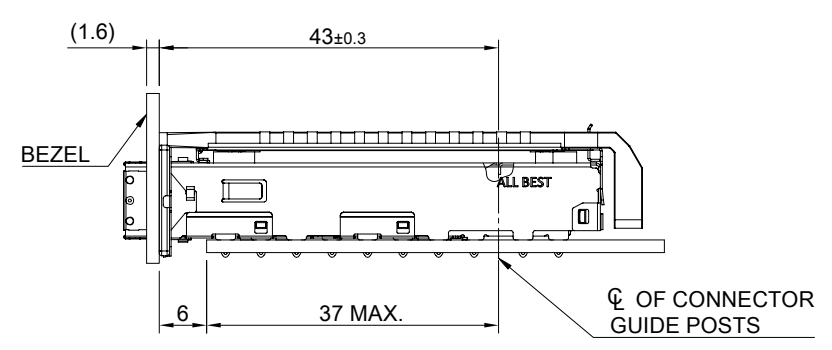

BELLY TO BELLY CONFIGURATION

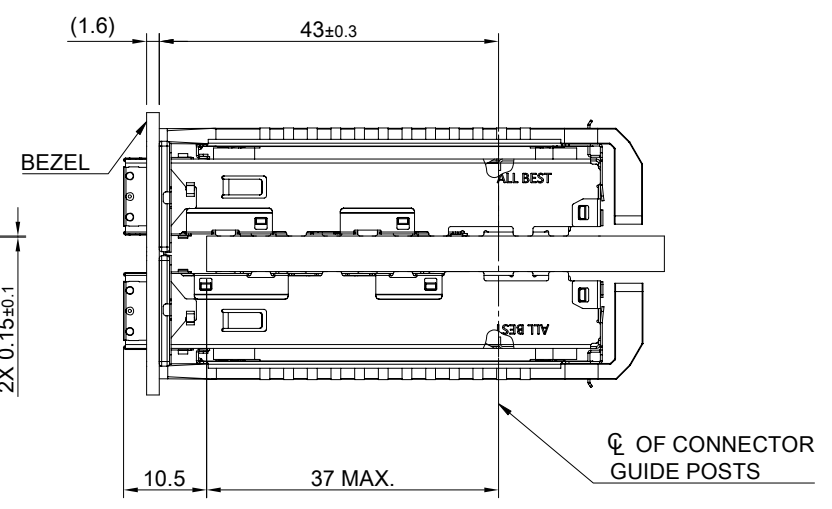



C = THICKNESS OF PC BOARD
 SINGLE-SIDE = 1.6MM (MIN.)
 BELLY TO BELLY = 4.5MM (MIN.)

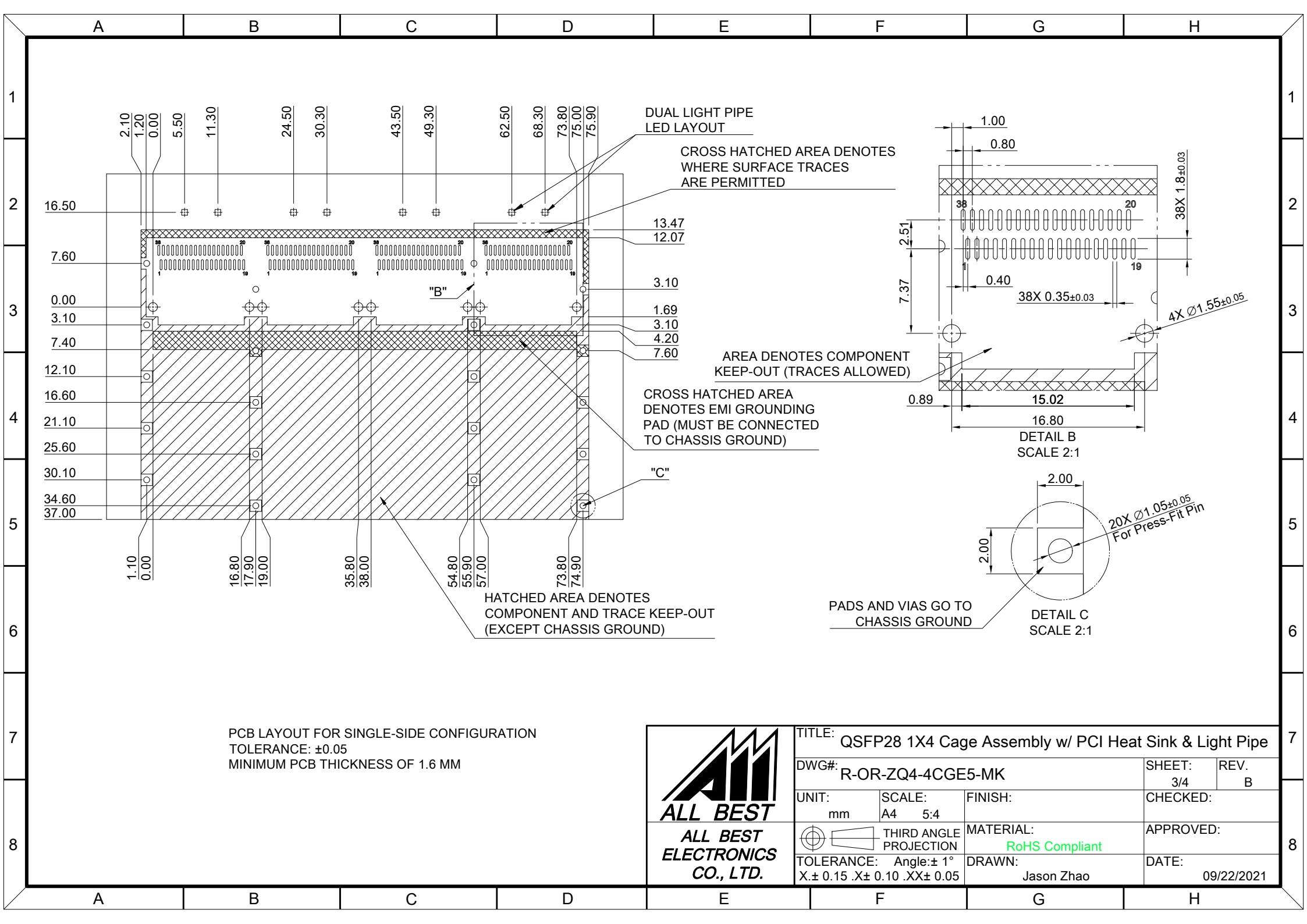

TITLE: QSFP28 1X4 Cage Assembly w/ PCI Heat Sink & Light Pipe			
DWG#: R-OR-ZQ4-4CGE5-MK		SHEET: 2/4	REV. B
UNIT: mm	SCALE: A4 1:1	FINISH:	
TOLERANCE: Angle: ± 1° X ± 0.15 .X ± 0.10 .XX ± 0.05		MATERIAL: RoHS Compliant	APPROVED:
THIRD ANGLE PROJECTION		DRAWN: Jason Zhao	DATE: 09/22/2021



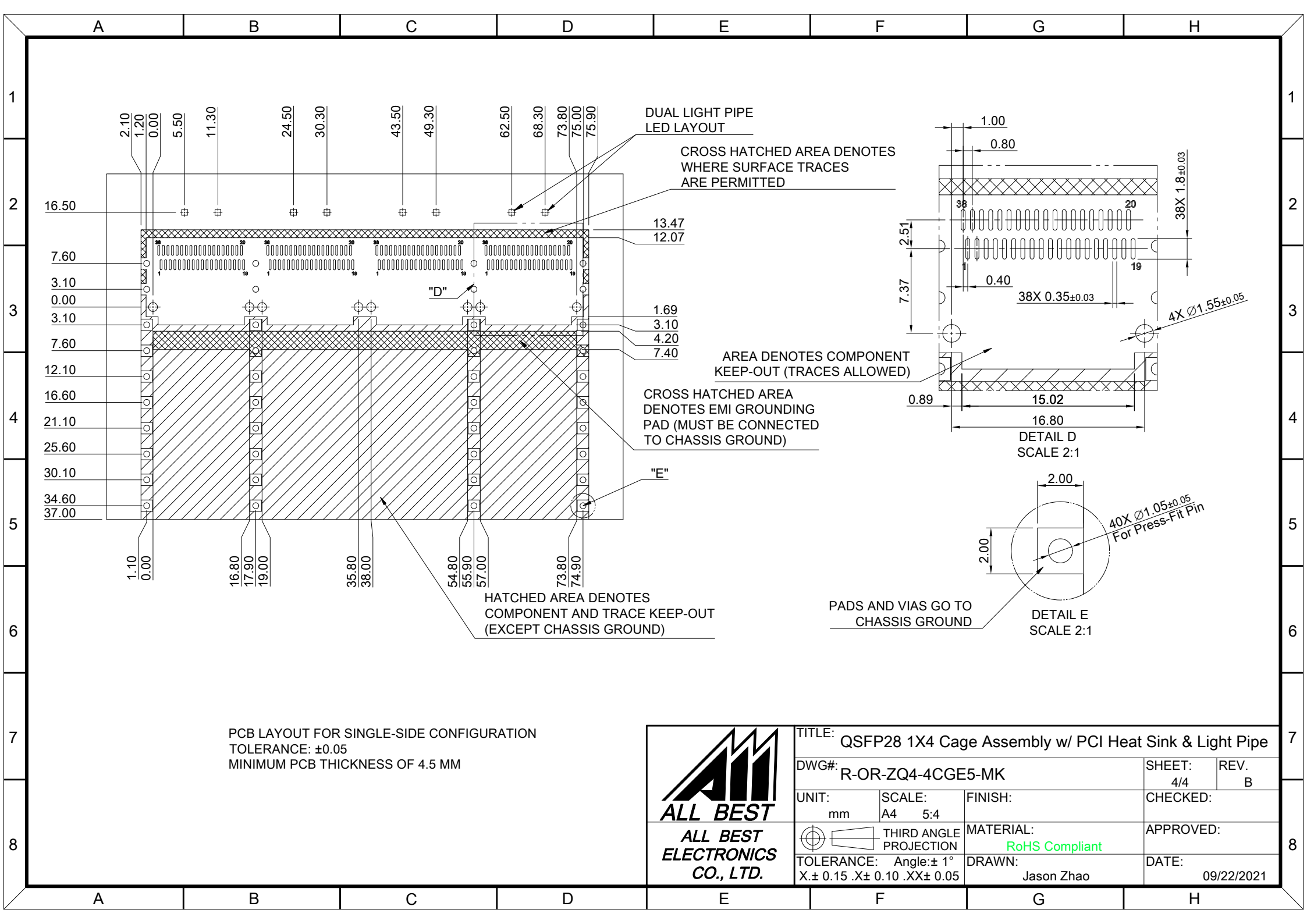

PCB LAYOUT FOR SINGLE-SIDE CONFIGURATION
 TOLERANCE: ±0.05
 MINIMUM PCB THICKNESS OF 1.6 MM

 ALL BEST ELECTRONICS CO., LTD.		TITLE: QSFP28 1X4 Cage Assembly w/ PCI Heat Sink & Light Pipe	
		DWG#: R-OR-ZQ4-4CGE5-MK	
UNIT: mm	SCALE: A4 5:4	FINISH:	SHEET: 3/4
 THIRD ANGLE PROJECTION		MATERIAL: RoHS Compliant	REV. B
TOLERANCE: Angle: ± 1° X. ± 0.15 .X ± 0.10 .XX ± 0.05		DRAWN: Jason Zhao	CHECKED:
		DATE: 09/22/2021	APPROVED:



PCB LAYOUT FOR SINGLE-SIDE CONFIGURATION
 TOLERANCE: ± 0.05
 MINIMUM PCB THICKNESS OF 4.5 MM

 ALL BEST ELECTRONICS CO., LTD.		TITLE: QSFP28 1X4 Cage Assembly w/ PCI Heat Sink & Light Pipe	
		DWG#: R-OR-ZQ4-4CGE5-MK	
UNIT: mm	SCALE: A4 5:4	FINISH:	SHEET: 4/4
 THIRD ANGLE PROJECTION		MATERIAL: RoHS Compliant	REV. B
TOLERANCE: Angle: $\pm 1^\circ$ X: ± 0.15 .X: ± 0.10 .XX: ± 0.05		DRAWN: Jason Zhao	CHECKED:
			APPROVED:
			DATE: 09/22/2021