

DETAIL A  
SCALE 4:1

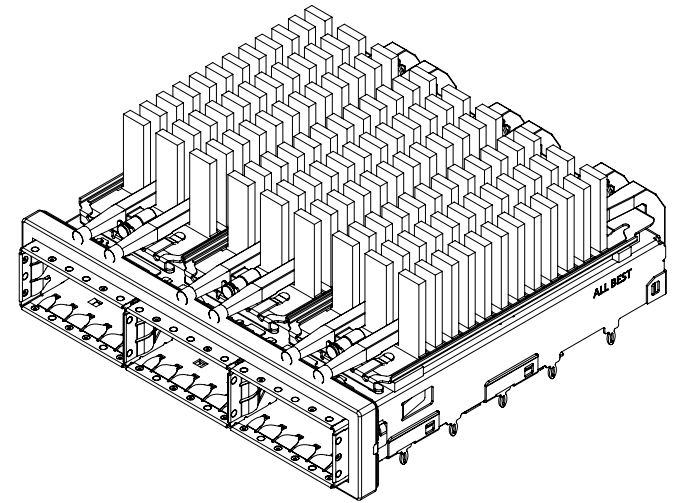

- MATERIAL  
 CAGE: NICKEL SILVER  
 EMI SPRING: STAINLESS STEEL  
 EMI GASKET FLANGE: STAINLESS STEEL  
 EMI GASKET: CONDUCTIVE ELASTOMER  
 HEAT SINK: ALUMINUM  
 HEAT SINK CLIP: STAINLESS STEEL  
 LIGHT PIPE: PC

- FINISH  
 HEAT SINK: ANODE PROCESS

NOTE  
 ▲ DIMENSION APPLIES WITH MODULE INSERTED IN CAGE

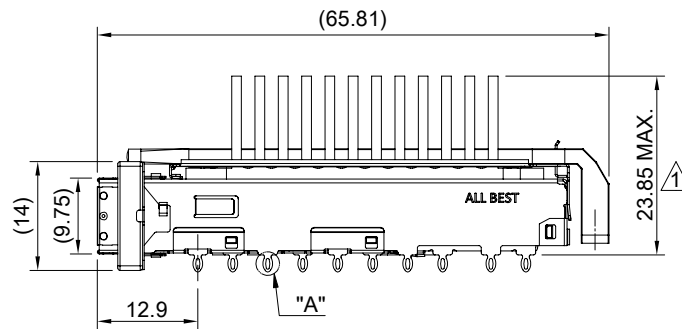
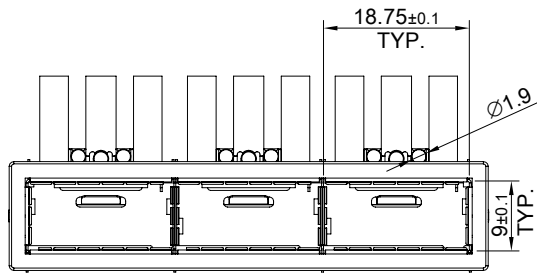

THIS PRINT IS  
**PRELIMINARY**  
 UNQUALIFIED PRODUCT  
 CONTACT PRODUCT ENGINEERING  
 BEFORE USING THIS PRINT



TITLE: QSFP56 1X3 Cage Assembly w/ Light Pipe & Heat Sink(NET)			
DWG#: R-OR-DZQ3-4CGE3-MK		SHEET: 1/4	REV. REF
UNIT: mm	SCALE: A4 1:1	CHECKED:	
THIRD ANGLE PROJECTION		MATERIAL: RoHS Compliant	
TOLERANCE: Angle: ± 1° X ± 0.25 .X ± 0.20 .XX ± 0.15		DRAWN: Pohsiung	APPROVED:
		DATE: 3/14/2024	

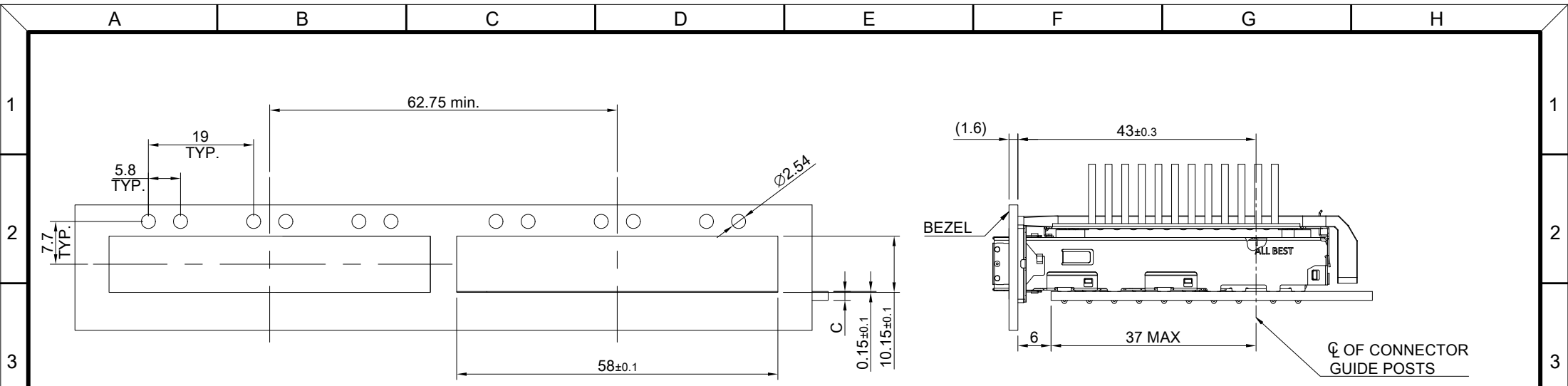

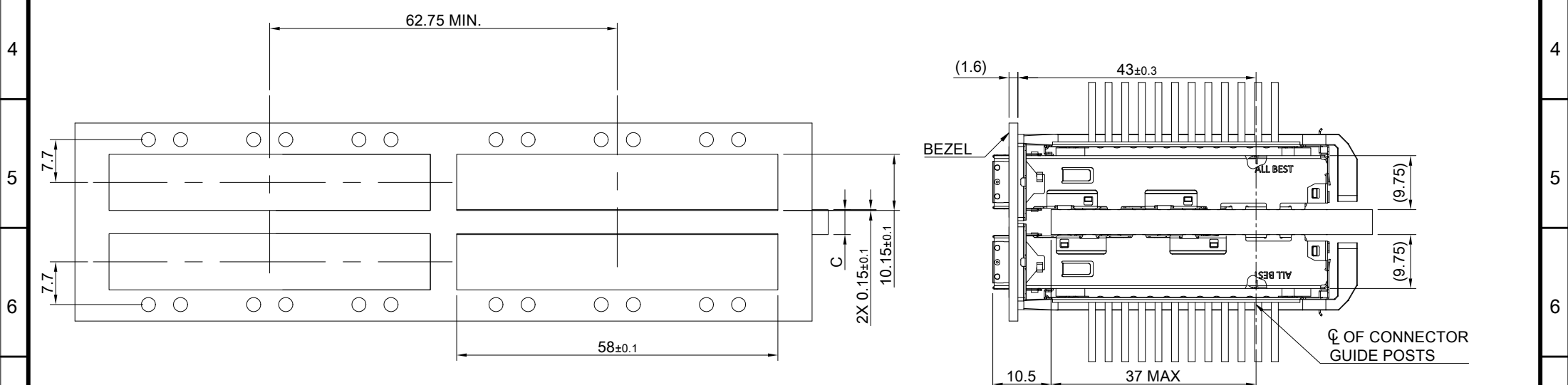

ONE SIDED CONFIGURATION



BELLY TO BELLY CONFIGURATION

C = THICKNESS OF PC BOARD  
 SINGLE SIDED= 1.6MM(MIN)  
 DOUBLE SIDE= 4.5MM(MIN)

THIS PRINT IS  
**PRELIMINARY**  
 UNQUALIFIED PRODUCT  
 CONTACT PRODUCT ENGINEERING  
 BEFORE USING THIS PRINT

 <b>ALL BEST ELECTRONICS CO., LTD.</b>	<b>TITLE:</b> QSFP56 1X3 Cage Assembly w/ Light Pipe & Heat Sink(NET)		<b>SHEET:</b> 2/4		<b>REV. REF</b>	
	<b>DWG#:</b> R-OR-DZQ3-4CGE3-MK		<b>CHECKED:</b>		<b>APPROVED:</b>	
<b>UNIT:</b> mm	<b>SCALE:</b> A4 1:1	<b>FINISH:</b>		<b>APPROVED:</b>		
 <b>THIRD ANGLE PROJECTION</b>		<b>MATERIAL:</b> RoHS Compliant		<b>DATE:</b> 3/14/2024		
<b>TOLERANCE:</b> Angle:± 1° X.± 0.15 .X± 0.10 .XX± 0.05		<b>DRAWN:</b> Pohsiung				

DUAL LIGHT PIPE LED LAYOUT

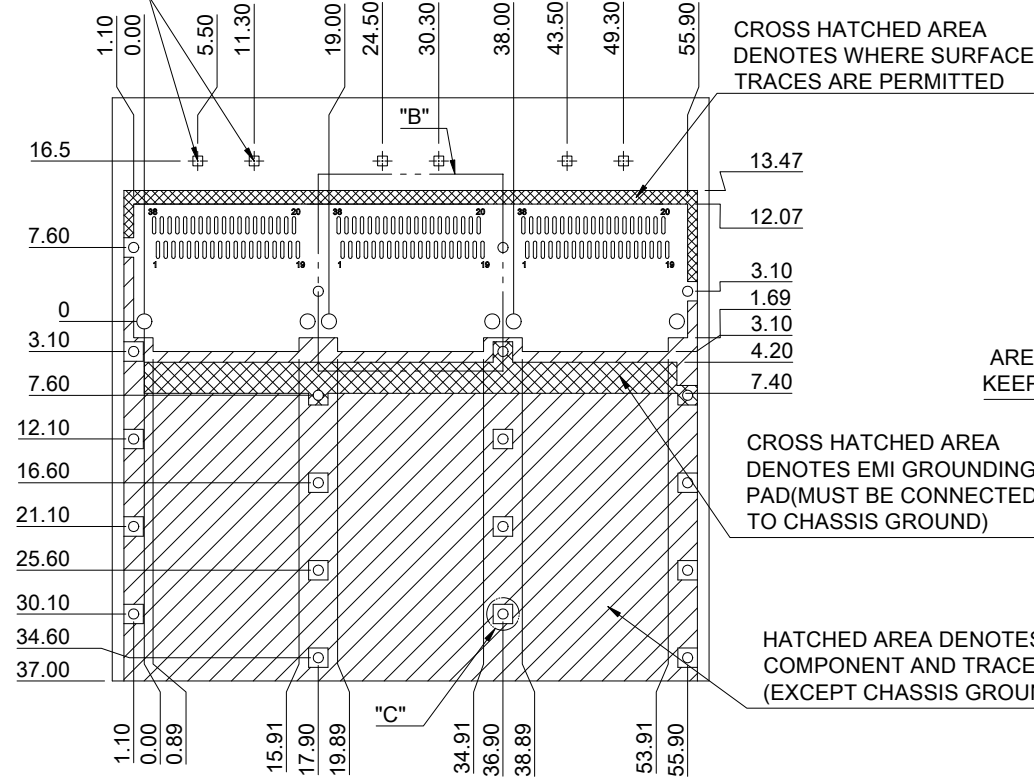

AREA DENOTES COMPONENT KEEP-OUT (TRACES ALLOWED)

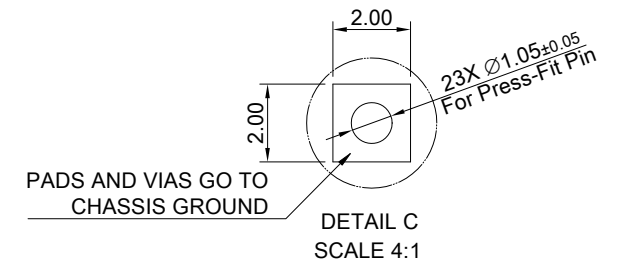
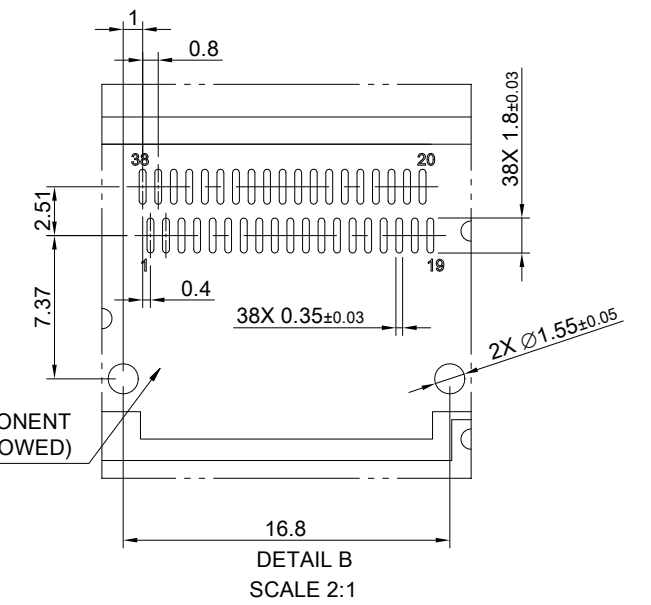

SINGLE SIDE PCB LAYOUT  
TOLERANCE: ±0.05  
MINIMUM PCB THICKNESS OF 1.6 MM

THIS PRINT IS  
**PRELIMINARY**  
UNQUALIFIED PRODUCT  
CONTACT PRODUCT ENGINEERING  
BEFORE USING THIS PRINT

 <b>ALL BEST</b> ALL BEST ELECTRONICS CO., LTD.	TITLE: QSFP56 1X3 Cage Assembly w/ Light Pipe & Heat Sink(NET)		SHEET: 3/4	REV. REF
	DWG#: R-OR-DZQ3-4CGE3-MK		CHECKED:	APPROVED:
UNIT: mm	SCALE: A4 5:4	FINISH:	DATE: 3/14/2024	
TOLERANCE: Angle: ± 1° X: ± 0.15 .X: ± 0.10 .XX: ± 0.05		MATERIAL: RoHS Compliant	DRAWN: Pohsiung	

DUAL LIGHT PIPE LED LAYOUT

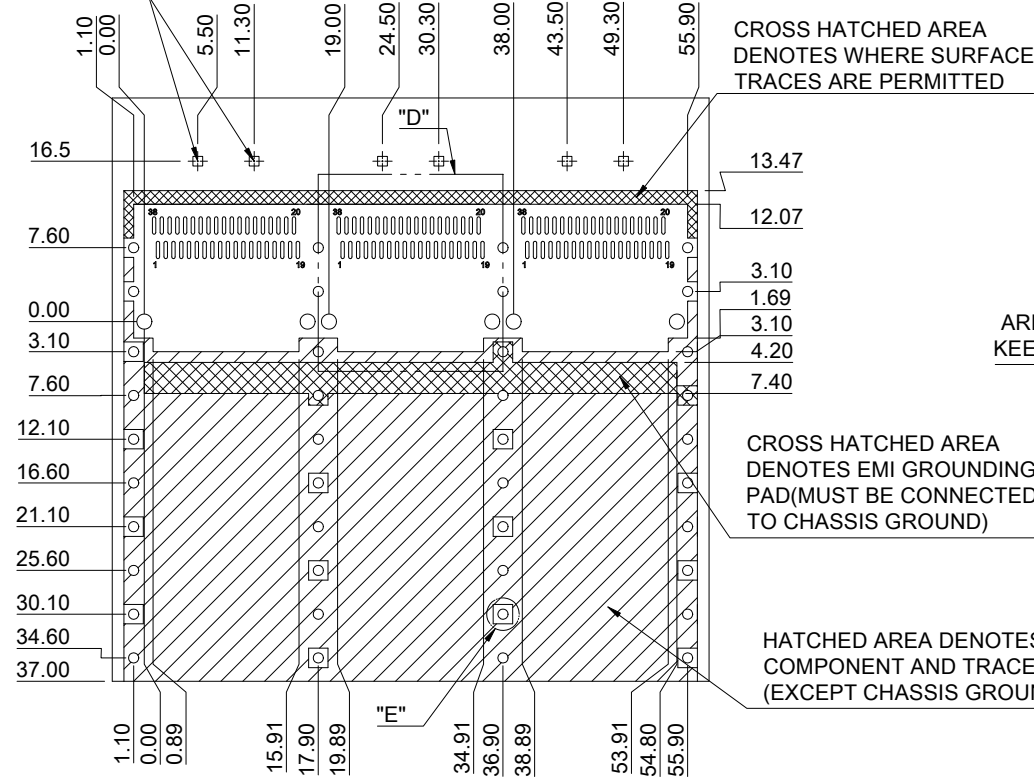

AREA DENOTES COMPONENT KEEP-OUT (TRACES ALLOWED)

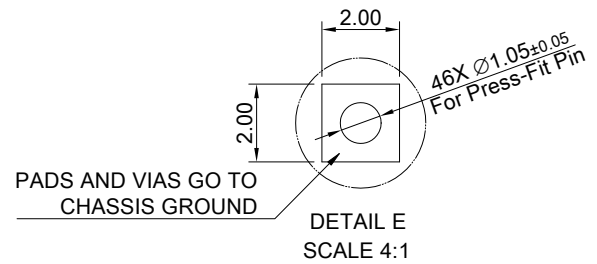
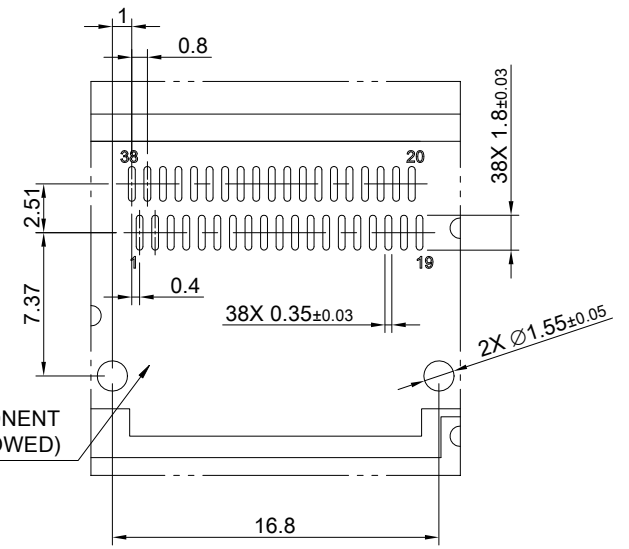

SINGLE SIDE PCB LAYOUT  
TOLERANCE:  $\pm 0.05$   
MINIMUM PCB THICKNESS OF 4.5 MM

THIS PRINT IS  
**PRELIMINARY**  
UNQUALIFIED PRODUCT  
CONTACT PRODUCT ENGINEERING  
BEFORE USING THIS PRINT

<p><b>ALL BEST</b> ALL BEST ELECTRONICS CO., LTD.</p>	TITLE: QSFP56 1X3 Cage Assembly w/ Light Pipe & Heat Sink (NET)		SHEET: 4/4 REV. REF	
	DWG#: R-OR-DZQ3-4CGE3-MK		CHECKED:	
UNIT: mm	SCALE: A4 5:4	FINISH:		APPROVED:
TOLERANCE: Angle: $\pm 1^\circ$ X: $\pm 0.15$ .X: $\pm 0.10$ .XX: $\pm 0.05$		MATERIAL: <b>RoHS Compliant</b>	DATE: 3/14/2024	
THIRD ANGLE PROJECTION		DRAWN: Pohsiung		DATE: