

MATERIAL  
 CAGE: NICKEL SILVER  
 EMI SPRING: STAINLESS STEEL  
 LIGHT PIPE: PC  
 HEAT SINK: ALUMINUM  
 HEAT SINK CLIP: STAINLESS STEEL

FINISH  
 HEAT SINK: ANODE PROCESS

NOTE  
 ▲ DIMENSION APPLIES WITH MODULE INSERTED IN CAGE

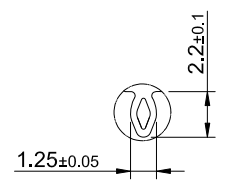

DETAIL A  
 SCALE 4:1

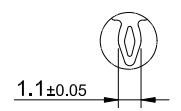

DETAIL B  
 SCALE 4:1



TITLE: SFP28 1X8 Cage Assembly w/ Light Pipe & Heat Sink			
DWG#: R-SH-0091X8-7-T-A1		SHEET: 1/4	REV. A
UNIT: mm	SCALE: A4 2:3	FINISH:	CHECKED: Gary Kang
THIRD ANGLE PROJECTION		MATERIAL: RoHS Compliant	APPROVED: George Yang
TOLERANCE: X.± 0.25 .X± 0.15 .XX± 0.05		DRAWN: Andy	DATE: 05/07/2019

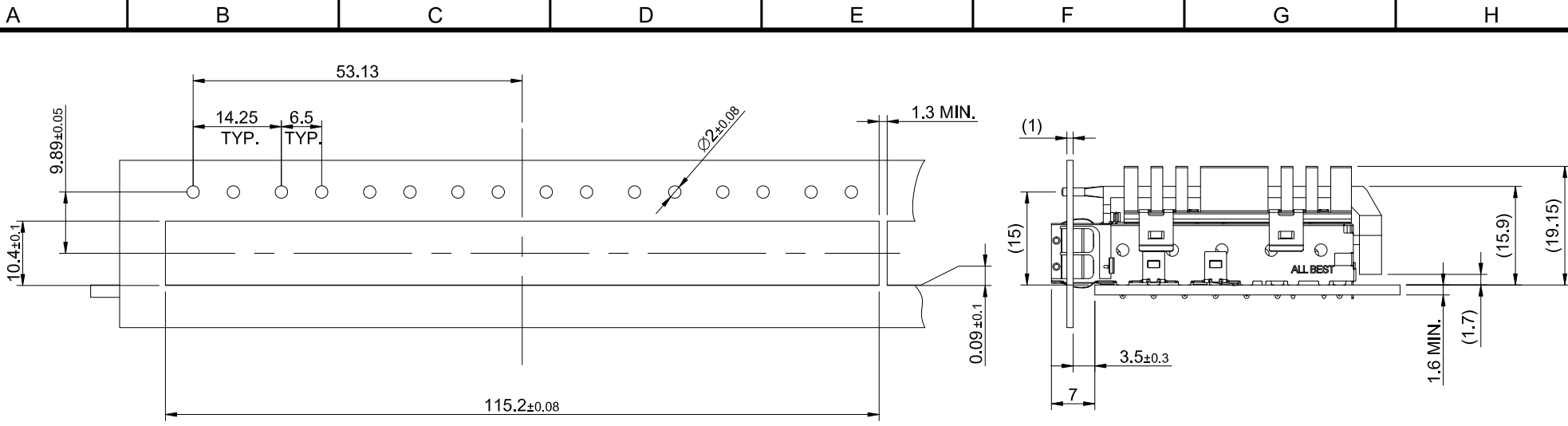

RECOMMENDED BEZEL CUT-OUT  
SINGLE-SIDE APPLICATIONS

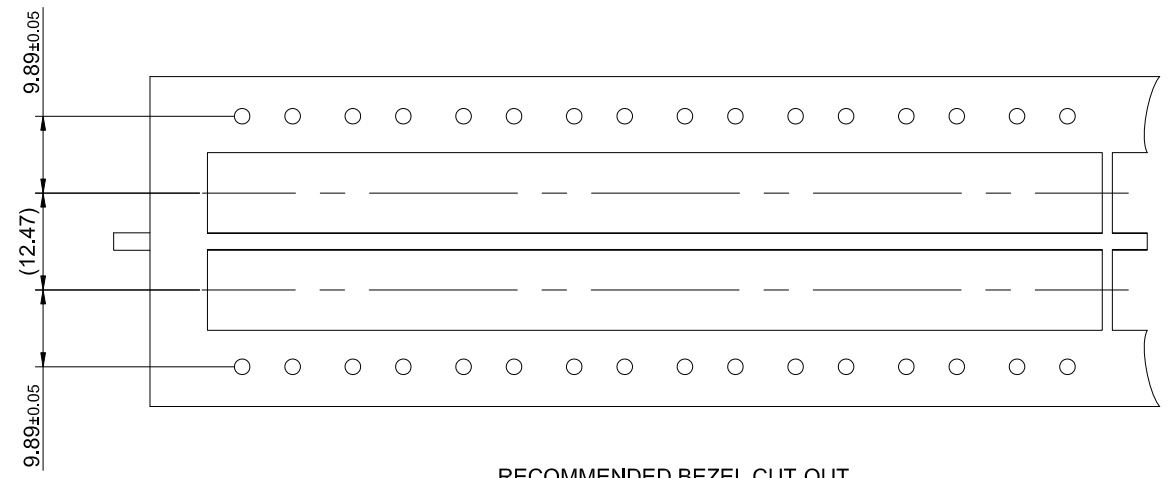

RECOMMENDED BEZEL CUT-OUT  
BELLY TO BELLY APPLICATIONS

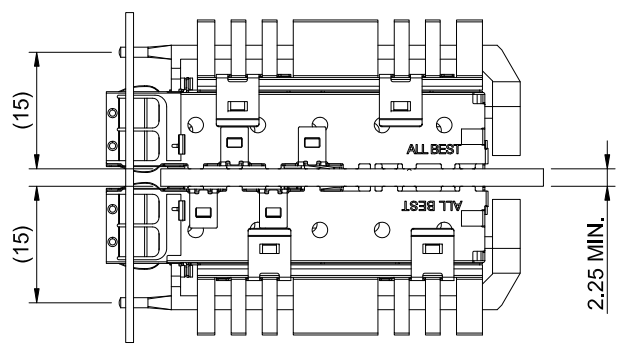

TITLE: SFP28 1X8 Cage Assembly w/ Light Pipe & Heat Sink			
DWG#: R-SH-0091X8-7-T-A1		SHEET: 2/4	REV. A
UNIT: mm	SCALE: A4 1:1	CHECKED: Gary Kang	
TOLERANCE: X± 0.15 .X± 0.10 .XX± 0.05		MATERIAL: RoHS Compliant	APPROVED: George Yang
THIRD ANGLE PROJECTION		DRAWN: Andy	DATE: 05/07/2019

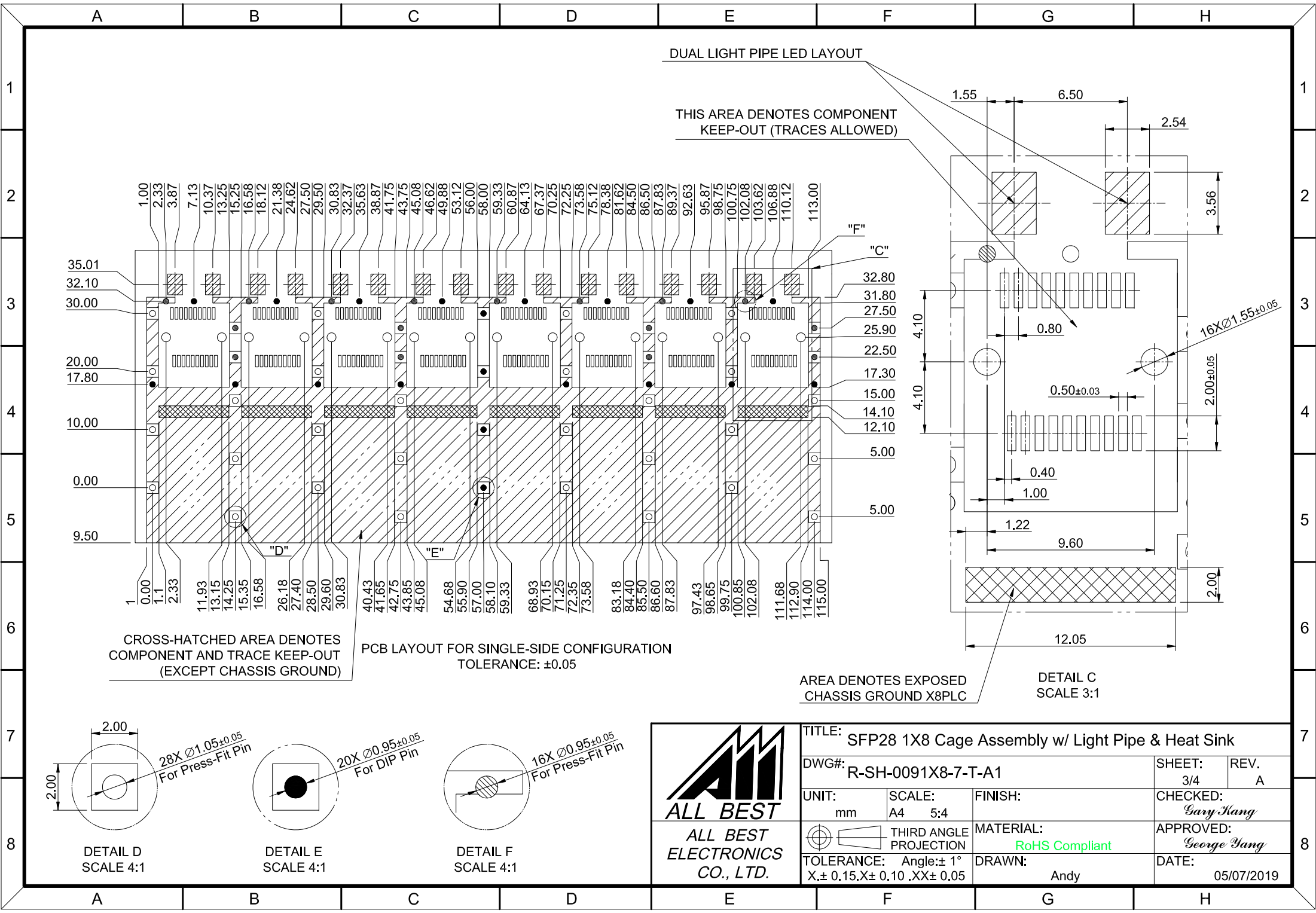

DUAL LIGHT PIPE LED LAYOUT

THIS AREA DENOTES COMPONENT KEEP-OUT (TRACES ALLOWED)

CROSS-HATCHED AREA DENOTES COMPONENT AND TRACE KEEP-OUT (EXCEPT CHASSIS GROUND)

PCB LAYOUT FOR SINGLE-SIDE CONFIGURATION TOLERANCE: ±0.05

AREA DENOTES EXPOSED CHASSIS GROUND X8PLC

DETAIL C SCALE 3:1

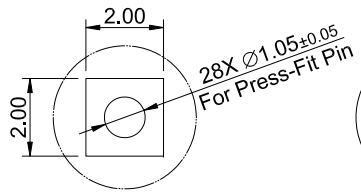

DETAIL D SCALE 4:1

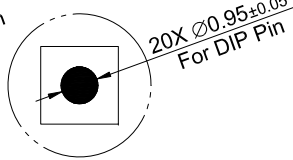

DETAIL E SCALE 4:1

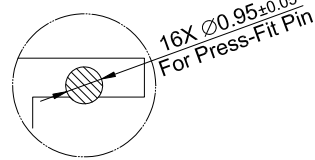

DETAIL F SCALE 4:1

**ALL BEST**  
ALL BEST ELECTRONICS CO., LTD.

TITLE: SFP28 1X8 Cage Assembly w/ Light Pipe & Heat Sink			
DWG#: R-SH-0091X8-7-T-A1		SHEET: 3/4	REV. A
UNIT: mm	SCALE: A4 5:4	FINISH:	CHECKED: Gary Kang
TOLERANCE: Angle: ±1° X ± 0.15, X ± 0.10, .XX ± 0.05		MATERIAL: RoHS Compliant	APPROVED: George Yang
THIRD ANGLE PROJECTION		DRAWN: Andy	DATE: 05/07/2019

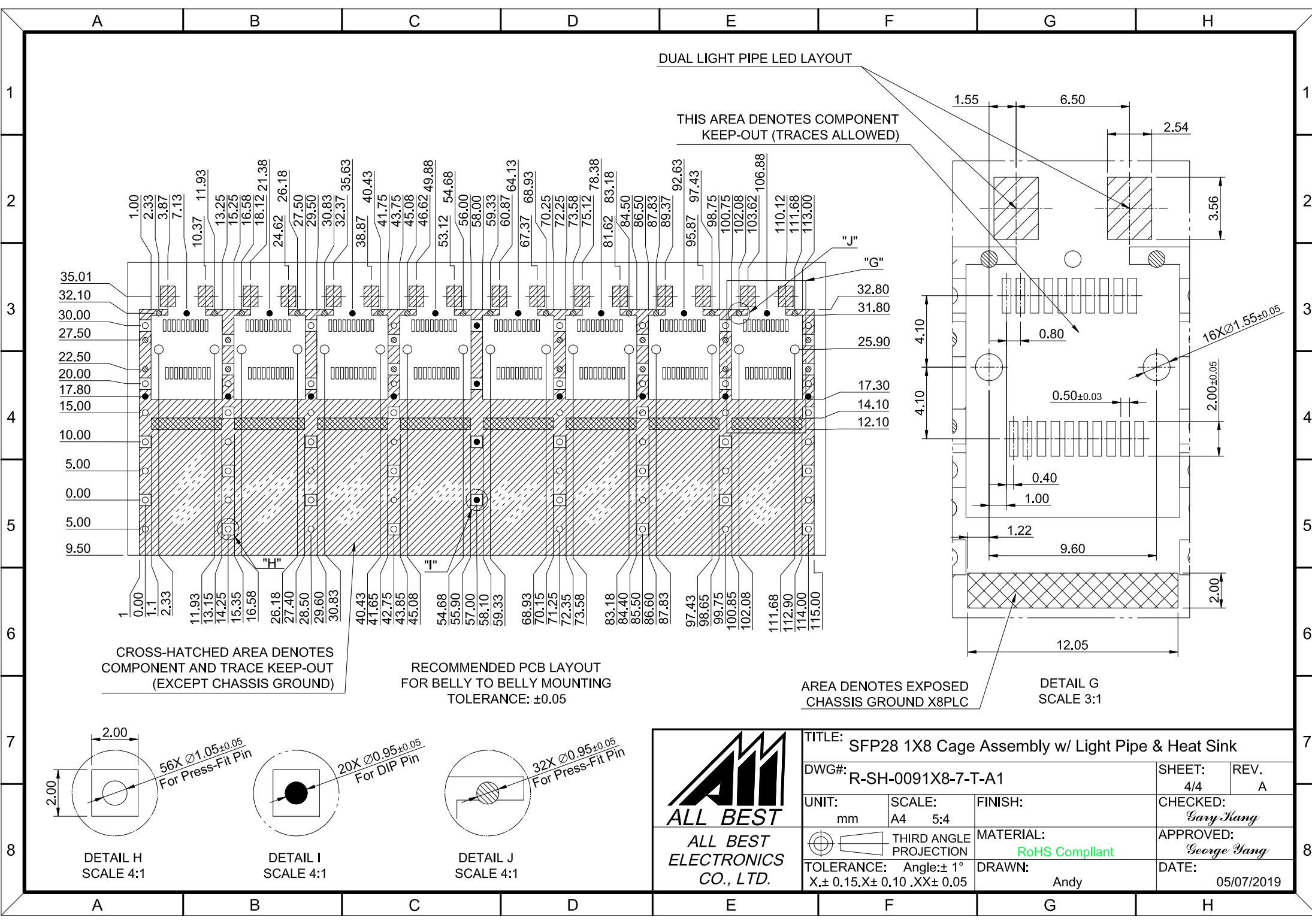

DUAL LIGHT PIPE LED LAYOUT

THIS AREA DENOTES COMPONENT  
KEEP-OUT (TRACES ALLOWED)

CROSS-HATCHED AREA DENOTES  
COMPONENT AND TRACE KEEP-OUT  
(EXCEPT CHASSIS GROUND)

RECOMMENDED PCB LAYOUT  
FOR BELLY TO BELLY MOUNTING  
TOLERANCE: ±0.05

AREA DENOTES EXPOSED  
CHASSIS GROUND X8PLC

DETAIL G  
SCALE 3:1

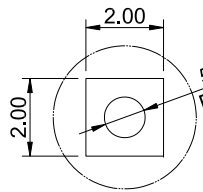

DETAIL H  
SCALE 4:1

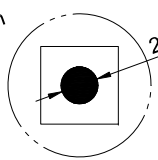

DETAIL I  
SCALE 4:1

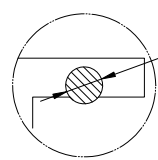

DETAIL J  
SCALE 4:1



ALL BEST  
ELECTRONICS  
CO., LTD.

TITLE: SFP28 1X8 Cage Assembly w/ Light Pipe & Heat Sink			
DWG#: R-SH-0091X8-7-T-A1		SHEET: 4/4	REV. A
UNIT: mm	SCALE: A4 5:4	FINISH:	CHECKED: Gary Kang
THIRD ANGLE PROJECTION		MATERIAL: RoHS Compliant	APPROVED: George Yang
TOLERANCE: Angle: ±1° X ± 0.15, X ± 0.10, .XX ± 0.05		DRAWN: Andy	DATE: 05/07/2019