

DETAIL A  
SCALE 5:1

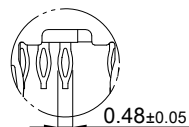

DETAIL B  
SCALE 5:1

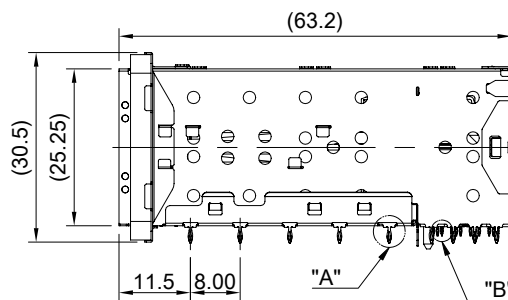
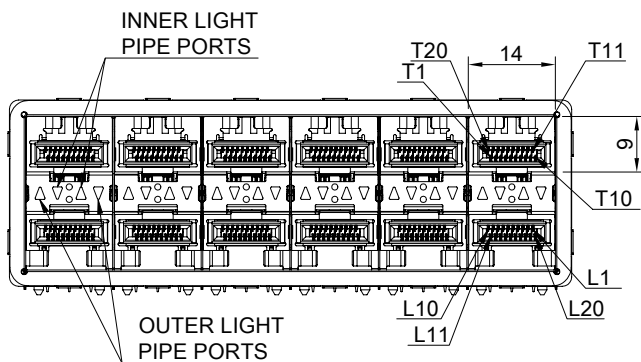
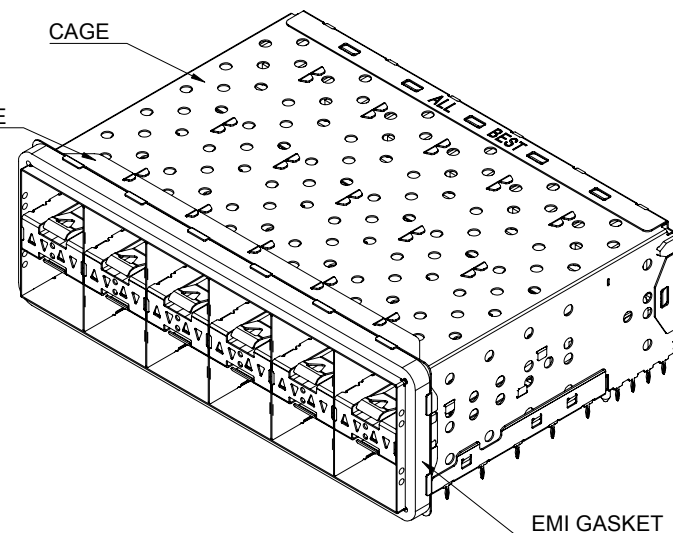

MATERIAL  
CAGE: NICKEL SILVER  
CONNECTOR HOUSING: THERMOPLASTIC, UL 94V-0  
CONNECTOR HOUSING SHIELD: STAINLESS STEEL  
CONTACTS: COPPER ALLOY  
EMI ELASTIC GASKET: CONDUCTIVE ELASTOMER  
EMI GASKET FLANGE: NICKEL SILVER  
LIGHT PIPE: PC (CLEAR)

FINISH  
CONTACT: 15µ" MIN. GOLD ON MATING END;  
30µ" MIN. MATTE TIN ON TERMINATION END;  
ALL UNDERPLATED 50µ" MIN. NICKEL

ELECTRICAL CHARACTERISTICS  
CONTACT CURRENT RATING: 0.5 AMPERE  
DIELECTRIC WITHSTANDING VOLTAGE: 300 VAC  
VOLTAGE RATING: 30 VAC  
CONTACT RESISTANCE: 80 mΩ MAX.

THIS PRINT IS  
PRELIMINARY  
UNQUALIFIED PRODUCT  
CONTACT PRODUCT ENGINEERING  
BEFORE USING THIS PRINT



TITLE: Stacked SFP28 2X6 ASS'Y w/ Light Pipe

DWG#: R-OP-0092X6-PP-F-N3-00-IO2

UNIT: mm

SCALE: A4 4:5

FINISH:

SHEET: 1/2  
REV. REF

THIRD ANGLE PROJECTION

MATERIAL: RoHS Compliant

APPROVED:

TOLERANCE: Angle: ± 1°  
X ± 0.25 .X ± 0.20 .XX ± 0.15

DRAWN: Tony

DATE: 03/26/2024

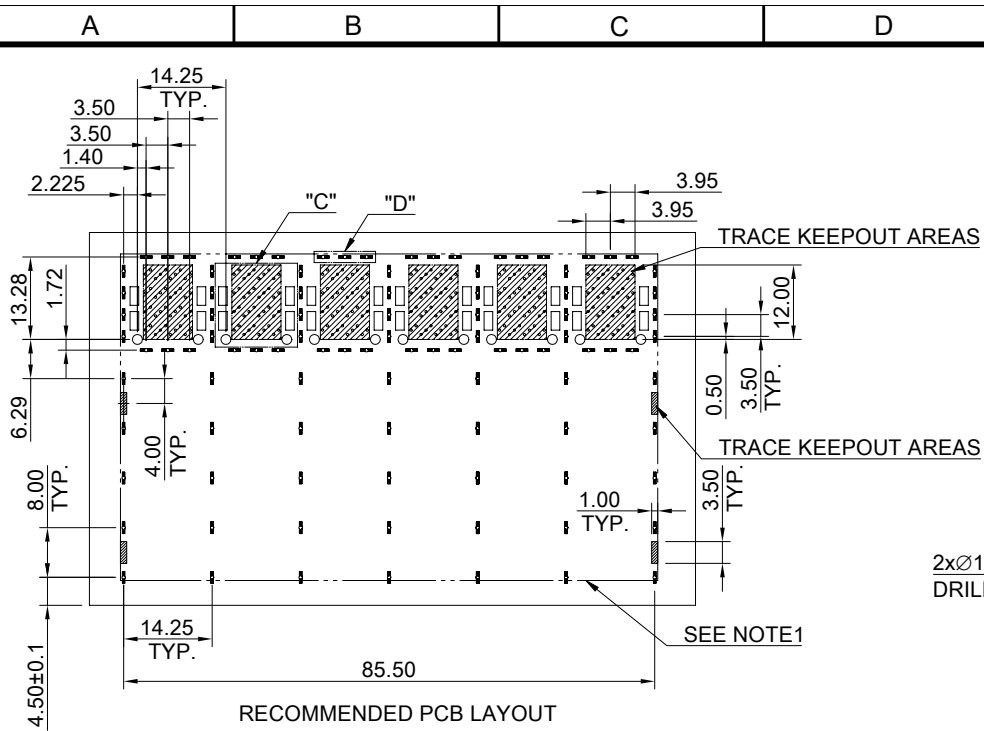

RECOMMENDED PCB LAYOUT  
TOLERANCE: ±0.05  
MINIMUM PCB THICKNESS OF 2MM

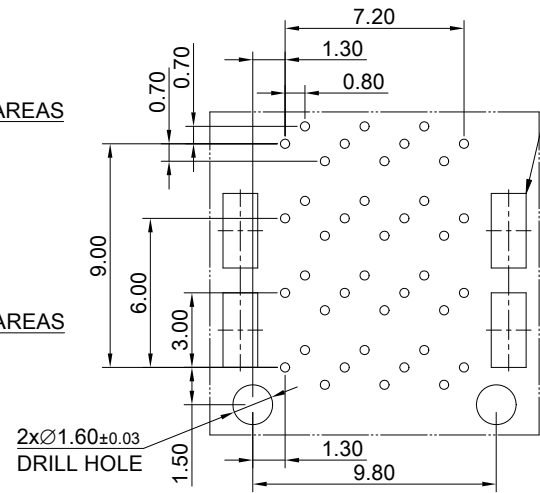

DETAIL C-1  
SCALE 4:1

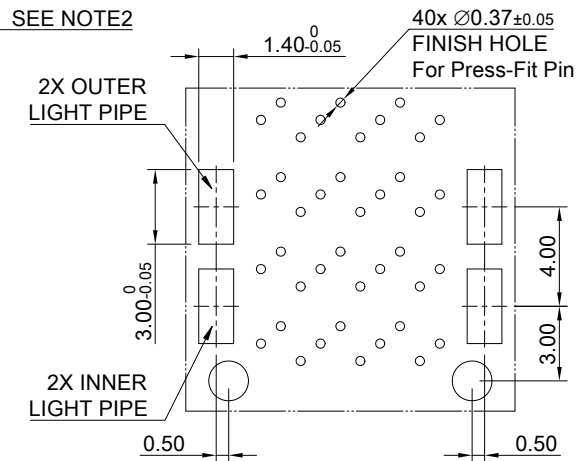

DETAIL C-2  
SCALE 4:1

- NOTE :
- 1.)THE ENTIRE AREA OF THE CONNECTOR FOOTPRINT, INDICATED BY THE DASHED LINE, TO BE CONSIDERED THE KEEPOUT AREA FOR COMPONENTS AND SIGNAL TRACES, TOP SIDE ONLY, TOP SIDE TRACES ALLOWED WITHIN CONNECTOR HOLE PATTERN.
  - 2.)LIGHT PIPE PAD LAYOUT IS FOR 0805 LOW PROFILE LED PACKAGE WITH A HEIGHT OF 0.8mm

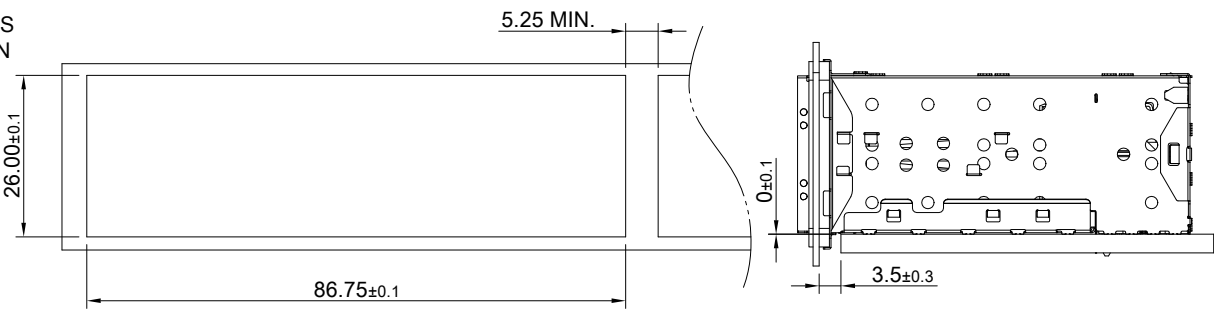

- T19 ○ T16 ○ T13 ○
- T20 ○ T17 ○ T14 ○ T11 ○
- T18 ○ T15 ○ T12 ○
  
- T2 ○ T5 ○ T8 ○
- T1 ○ T4 ○ T7 ○ T10 ○
- T3 ○ T6 ○ T9 ○
  
- L9 ○ L6 ○ L3 ○
- L10 ○ L7 ○ L4 ○ L1 ○
- L8 ○ L5 ○ L2 ○
  
- L12 ○ L15 ○ L18 ○
- L11 ○ L14 ○ L17 ○ L20 ○
- L13 ○ L16 ○ L19 ○

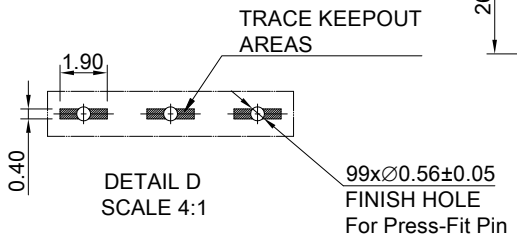

DETAIL D  
SCALE 4:1

THIS PRINT IS  
**PRELIMINARY**  
UNQUALIFIED PRODUCT  
CONTACT PRODUCT ENGINEERING  
BEFORE USING THIS PRINT



TITLE: Stacked SFP28 2X6 ASS'Y w/ Light Pipe			
DWG#: R-OP-0092X6-PP-F-N3-00-IO2		SHEET: 2/2	REV. REF
UNIT: mm	SCALE: A4 4:5	FINISH:	CHECKED:
THIRD ANGLE PROJECTION		MATERIAL: RoHS Compliant	APPROVED:
TOLERANCE: Angle: ± 1° X.± 0.15 .X± 0.10 .XX± 0.05		DRAWN: Tony	DATE: 03/26/2024