

DETAIL A
SCALE 5:1

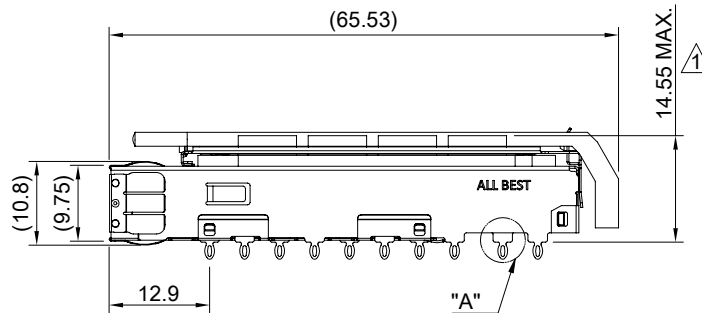
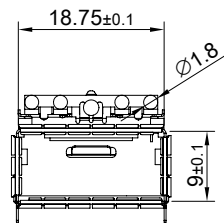
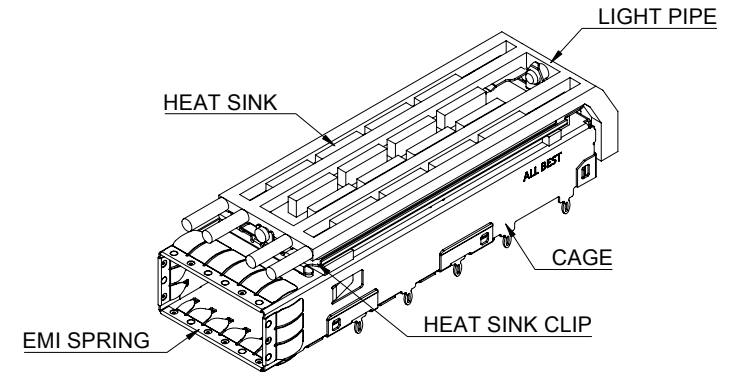

MATERIAL
 CAGE: NICKEL SILVER
 HEAT SINK: ALUMINUM
 HEAT SINK CLIP: STAINLESS STEEL
 EMI SPRING: STAINLESS STEEL
 LIGHT PIPE: PC

FINISH
 HEAT SINK: ANODE PROCESS

NOTE
 ▲ DIMENSION APPLIES WITH MODULE INSERTED IN CAGE

THIS PRINT IS
PRELIMINARY
 UNQUALIFIED PRODUCT
 CONTACT PRODUCT ENGINEERING
 BEFORE USING THIS PRINT



TITLE: QSFP56 1X1 Cage Assembly w/ Light Pipe & Heat Sink			
DWG#: R-OR-DZQ1-4CMEG-MK		SHEET: 1/4	REV. REF
UNIT: mm	SCALE: A4 1:1	FINISH:	CHECKED:
TOLERANCE: Angle: ± 1° X.± 0.25 .X± 0.20 .XX± 0.15		MATERIAL: RoHS Compliant	APPROVED:
THIRD ANGLE PROJECTION		DRAWN: Pohsiung	DATE: 3/14/2024

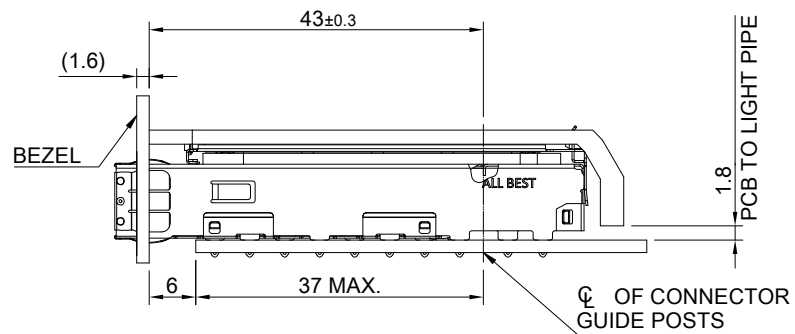
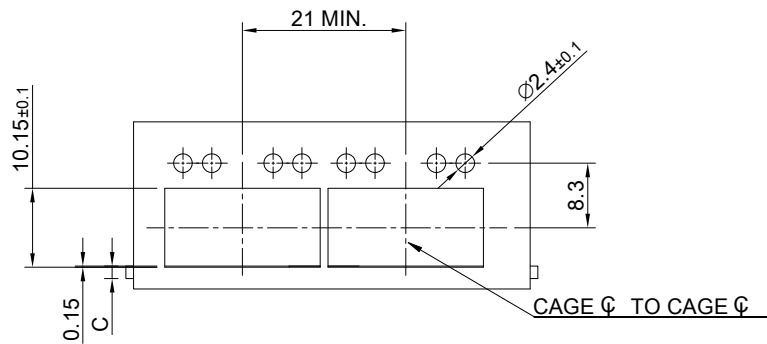

SINGLE-SIDE CONFIGURATION

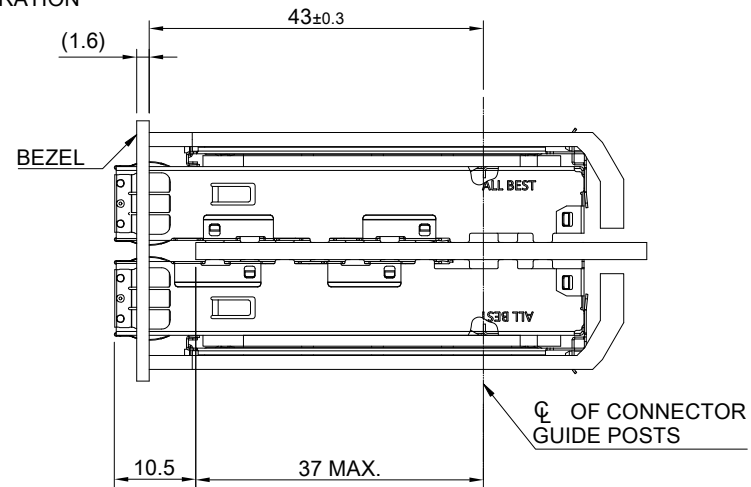
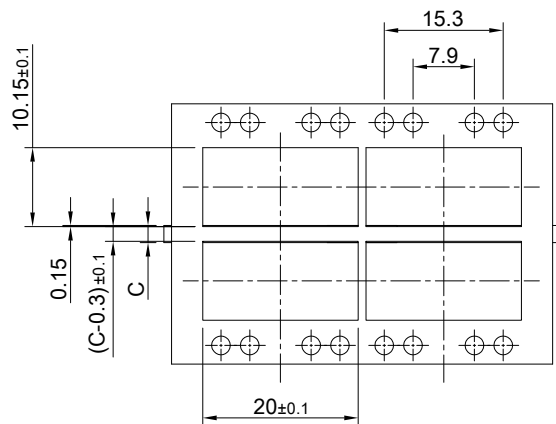

BELLY TO BELLY CONFIGURATION

C = THICKNESS OF PC BOARD
 SINGLE-SIDE = 1.6MM (MIN.)
 BELLY TO BELLY = 2.2MM (MIN.)

THIS PRINT IS
PRELIMINARY
 UNQUALIFIED PRODUCT
 CONTACT PRODUCT ENGINEERING
 BEFORE USING THIS PRINT



TITLE: QSFP56 1X1 Cage Assembly w/ Light Pipe & Heat Sink

DWG#: R-OR-DZQ1-4CMEG-MK

UNIT: mm

SCALE: A4 1:1

FINISH:

SHEET: 2/4
 REV. REF

THIRD ANGLE PROJECTION

MATERIAL: RoHS Compliant

APPROVED:

TOLERANCE: Angle: ± 1°
 X.± 0.15 .X± 0.10 .XX± 0.05

DRAWN: Pohsiung

DATE: 3/14/2024

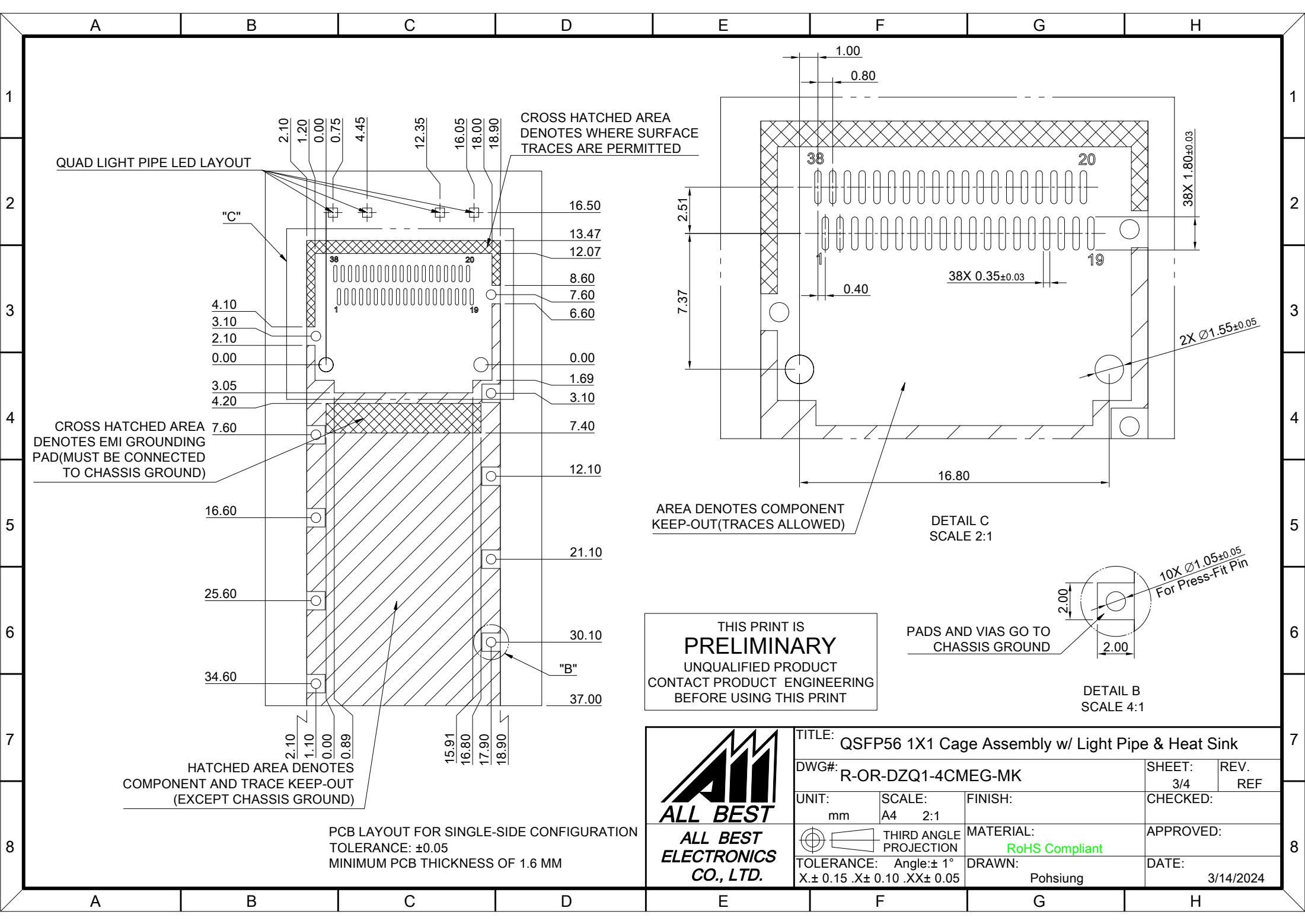

QUAD LIGHT PIPE LED LAYOUT

CROSS HATCHED AREA DENOTES WHERE SURFACE TRACES ARE PERMITTED

CROSS HATCHED AREA DENOTES EMI GROUNDING PAD (MUST BE CONNECTED TO CHASSIS GROUND)

HATCHED AREA DENOTES COMPONENT AND TRACE KEEP-OUT (EXCEPT CHASSIS GROUND)

PCB LAYOUT FOR SINGLE-SIDE CONFIGURATION
TOLERANCE: ±0.05
MINIMUM PCB THICKNESS OF 1.6 MM

AREA DENOTES COMPONENT KEEP-OUT (TRACES ALLOWED)

DETAIL C
SCALE 2:1

PADS AND VIAS GO TO CHASSIS GROUND

DETAIL B
SCALE 4:1

THIS PRINT IS
PRELIMINARY
UNQUALIFIED PRODUCT
CONTACT PRODUCT ENGINEERING
BEFORE USING THIS PRINT



TITLE: QSFP56 1X1 Cage Assembly w/ Light Pipe & Heat Sink			
DWG#: R-OR-DZQ1-4CMEG-MK		SHEET: 3/4	REV. REF
UNIT: mm	SCALE: A4 2:1	CHECKED:	
THIRD ANGLE PROJECTION		APPROVED:	
TOLERANCE: Angle: ± 1° X ± 0.15 .X ± 0.10 .XX ± 0.05		MATERIAL: RoHS Compliant	DATE: 3/14/2024
		DRAWN: Pohsiung	

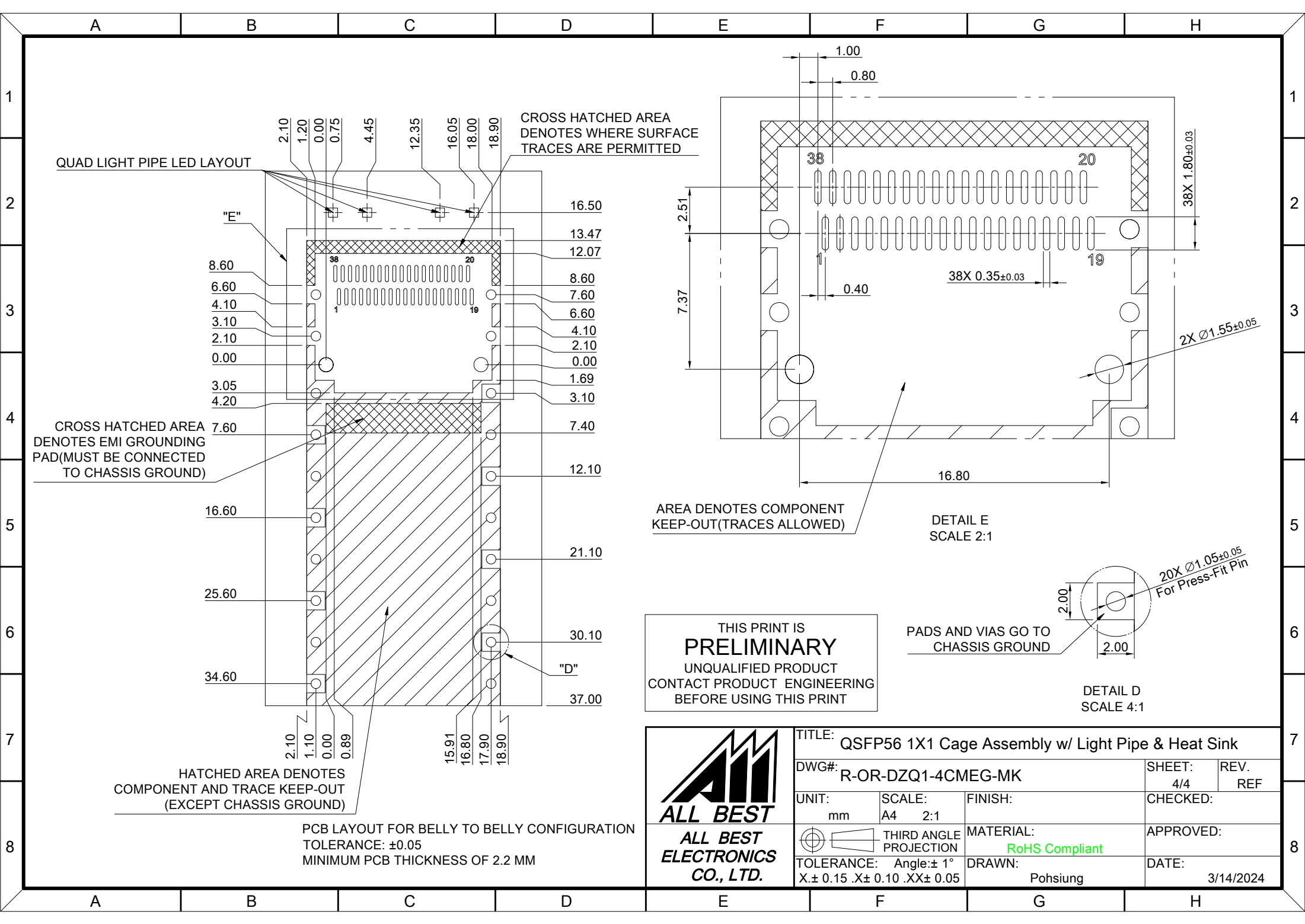

THIS PRINT IS
PRELIMINARY
UNQUALIFIED PRODUCT
CONTACT PRODUCT ENGINEERING
BEFORE USING THIS PRINT

 ALL BEST ALL BEST ELECTRONICS CO., LTD.	TITLE: QSFP56 1X1 Cage Assembly w/ Light Pipe & Heat Sink			SHEET: 4/4		REV. REF	
	DWG#: R-OR-DZQ1-4CMEG-MK			CHECKED:		APPROVED:	
	UNIT: mm	SCALE: A4 2:1	FINISH:		MATERIAL: RoHS Compliant		DATE: 3/14/2024
	TOLERANCE: X±0.15 .X±0.10 .XX±0.05		THIRD ANGLE PROJECTION	DRAWN: Pohsiung			