

A B C D E F G H

1
2
3
4
5
6
7
8

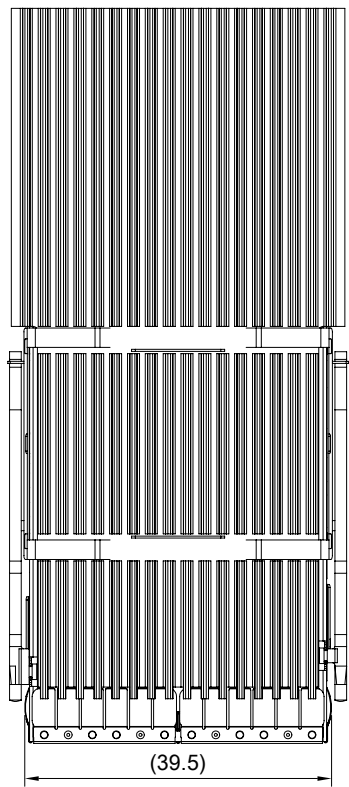

(39.5)

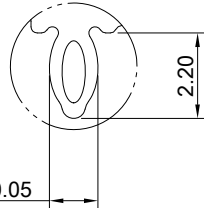

DETAIL A
SCALE 5:1

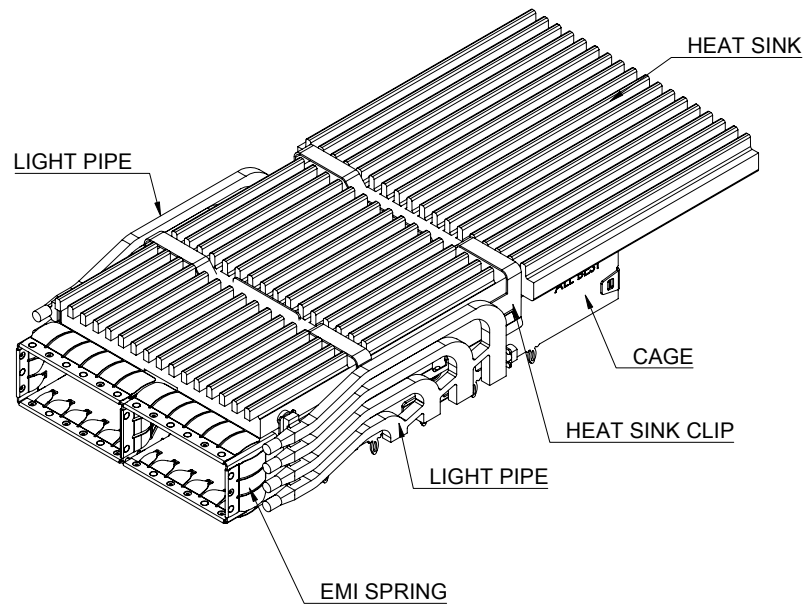

MATERIAL
 CAGE: NICKEL SILVER
 HEAT SINK: ALUMINUM
 HEAT SINK CLIP: STAINLESS STEEL
 EMI SPRING: STAINLESS STEEL
 LIGHT PIPE: PC

FINISH
 HEAT SINK: ANODE PROCESS

NOTE
 ▲ DIMENSION APPLIES WITH MODULE INSERTED IN CAGE

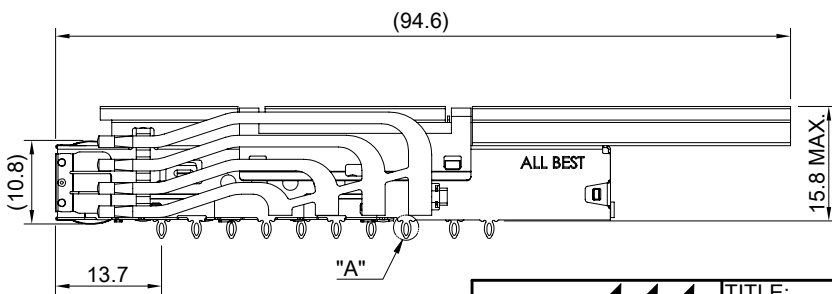
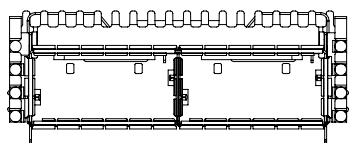

THIS PRINT IS
PRELIMINARY
 UNQUALIFIED PRODUCT
 CONTACT PRODUCT ENGINEERING
 BEFORE USING THIS PRINT



TITLE: QSFP-DD 1X2 Cage w/ Heat Sink & Light Pipe			
DWG#: R-OR-QD2-4CME6-MKLR4		SHEET: 1/4	REV. REF.
UNIT: mm	SCALE: A4 1:1	CHECKED:	
THIRD ANGLE PROJECTION		APPROVED:	
TOLERANCE: Angle: ± 1°		MATERIAL: RoHS Compliant	DATE: 03/22/2024
X ± 0.25 .X ± 0.20 .XX ± 0.15		DRAWN: Jason Zhao	

A B C D E F G H

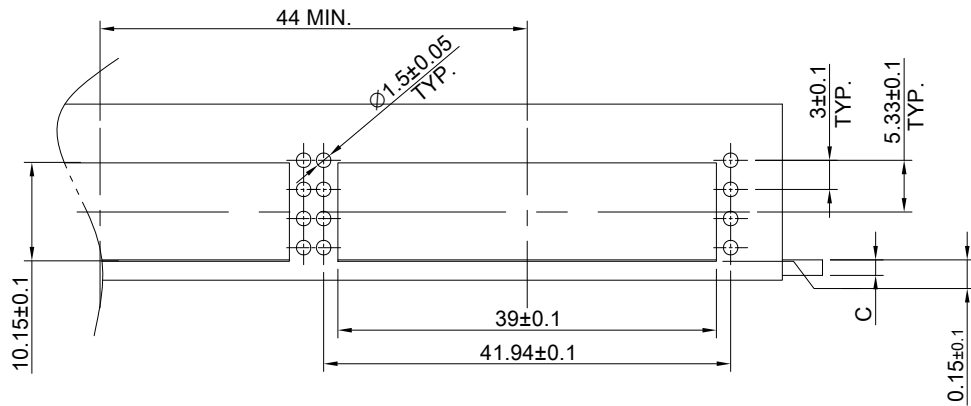

SINGLE-SIDE CONFIGURATION

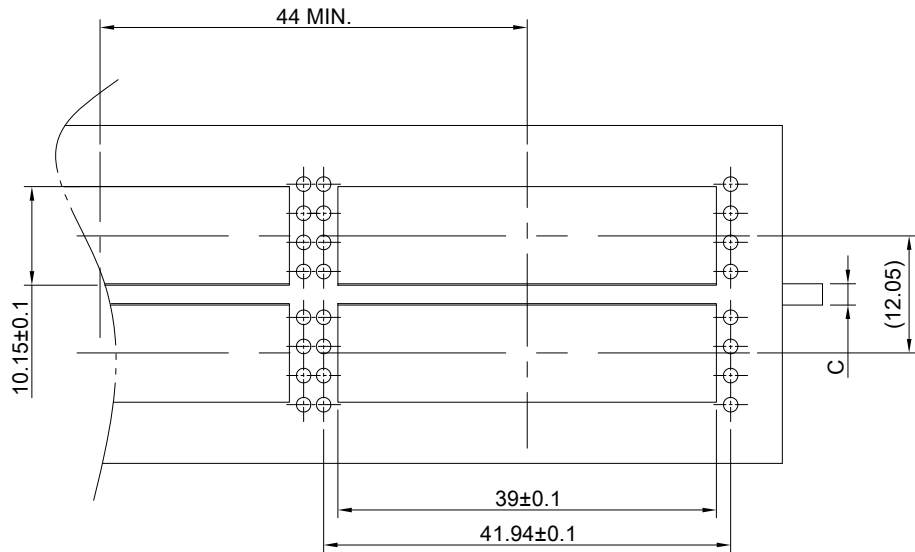

BELLY TO BELLY CONFIGURATION

C = THICKNESS OF PC BOARD
 SINGLE-SIDE = 1.6MM (MIN.)
 BELLY TO BELLY = 2.2MM (MIN.)

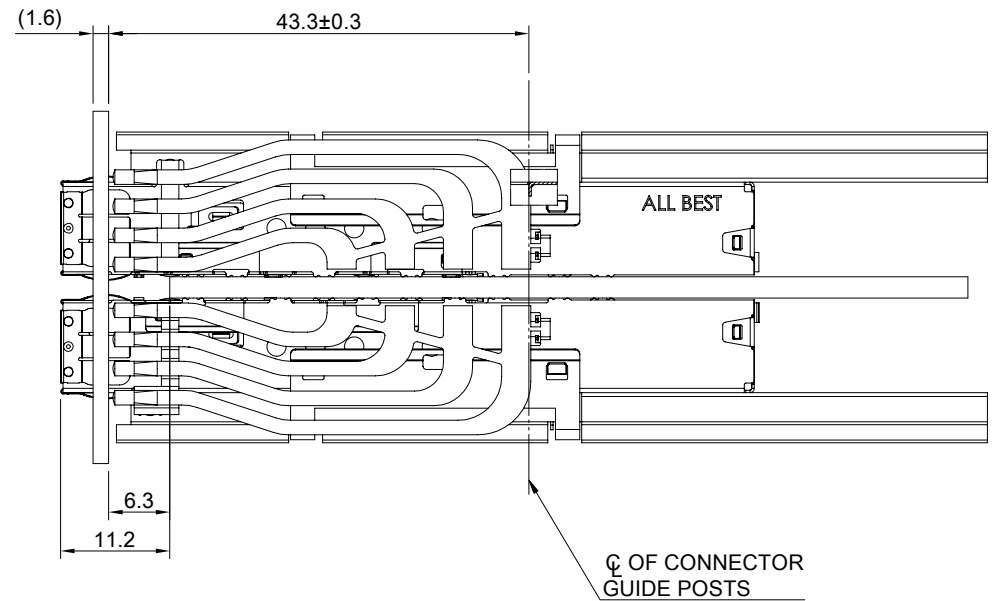
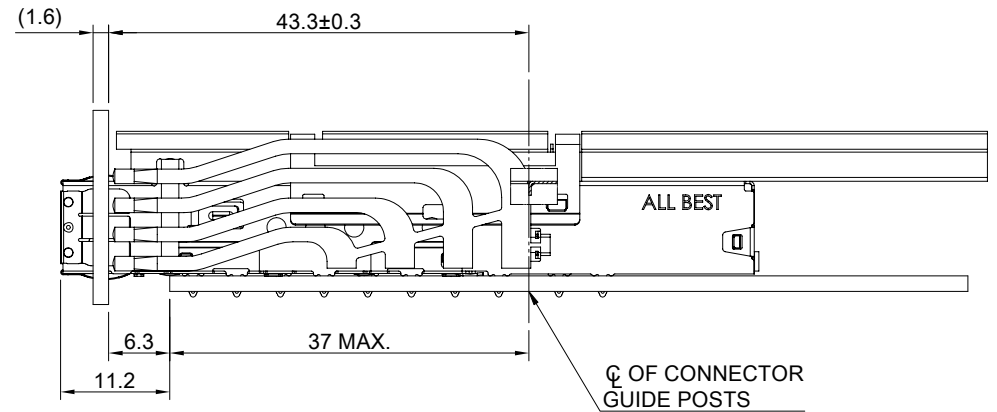

THIS PRINT IS
PRELIMINARY
 UNQUALIFIED PRODUCT
 CONTACT PRODUCT ENGINEERING
 BEFORE USING THIS PRINT



TITLE: QSFP-DD 1X2 Cage w/ Heat Sink & Light Pipe			
DWG#: R-OR-QD2-4CME6-MKLR4		SHEET: 2/4	REV. REF.
UNIT: mm	SCALE: A4 5:4	CHECKED:	
THIRD ANGLE PROJECTION		APPROVED:	
TOLERANCE: Angle: ± 1° X ± 0.15 .X ± 0.10 .XX ± 0.05		MATERIAL: RoHS Compliant	DATE: 03/22/2024
		DRAWN: Jason Zhao	

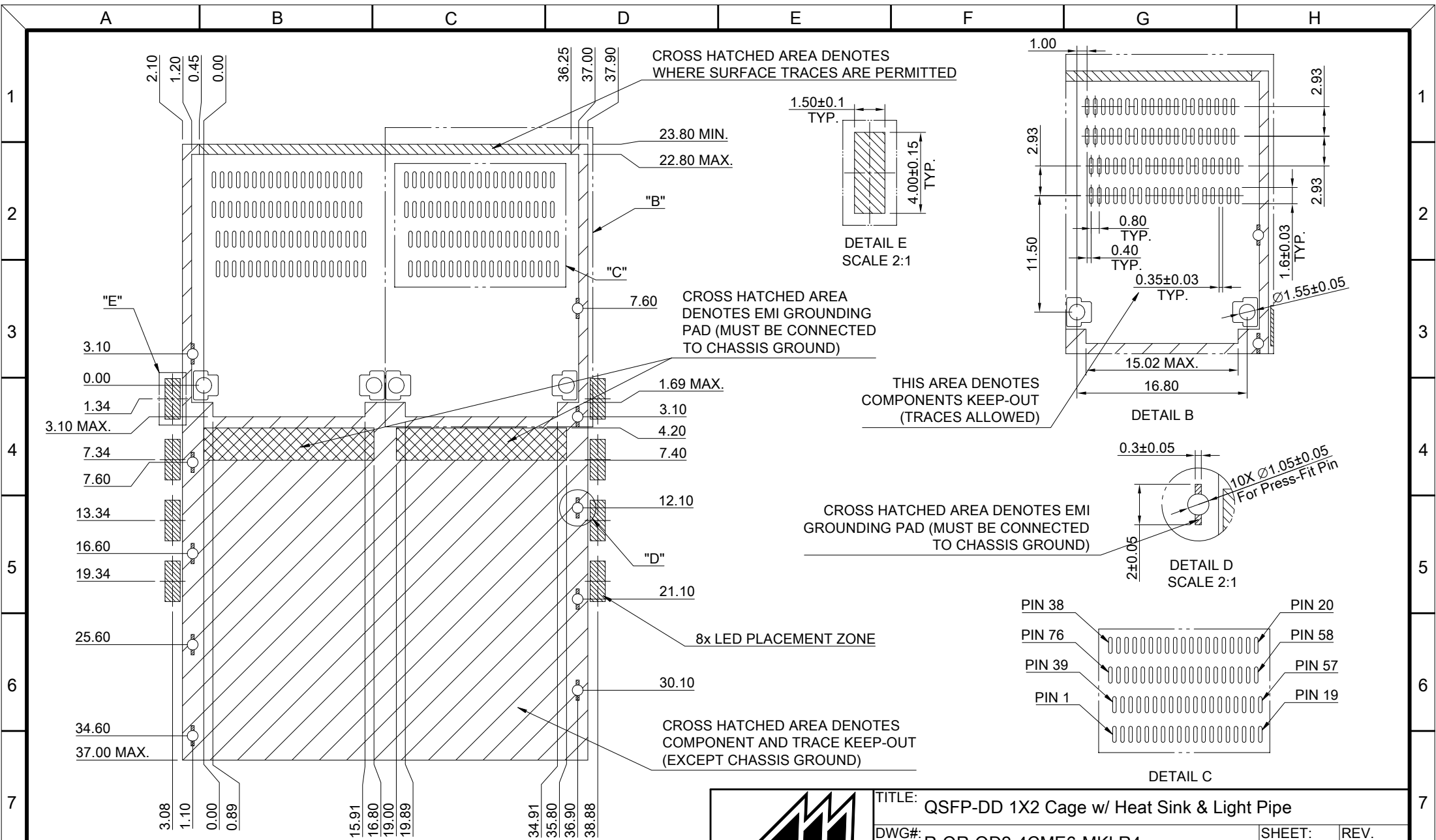

THIS PRINT IS
PRELIMINARY
UNQUALIFIED PRODUCT
CONTACT PRODUCT ENGINEERING
BEFORE USING THIS PRINT

PCB LAYOUT FOR SINGLE-SIDE CONFIGURATION
TOLERANCE: ±0.05
MINIMUM PCB THICKNESS OF 1.6 MM



TITLE: QSFP-DD 1X2 Cage w/ Heat Sink & Light Pipe			
DWG#: R-OR-QD2-4CME6-MKLR4		SHEET: 3/4	REV. REF.
UNIT: mm	SCALE: A4 2:1	FINISH:	CHECKED:
THIRD ANGLE PROJECTION		MATERIAL: RoHS Compliant	APPROVED:
TOLERANCE: X±0.15 .X±0.10 .XX±0.05		DRAWN: Jason Zhao	DATE: 03/22/2024

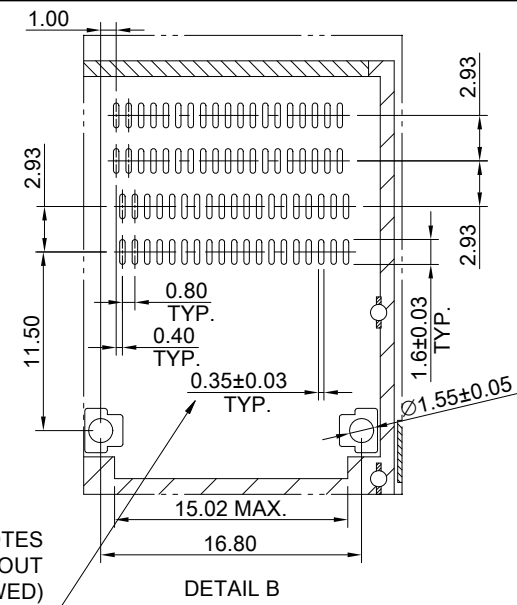
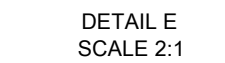
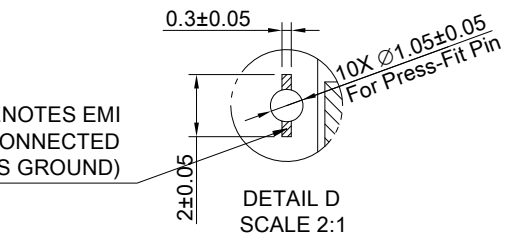
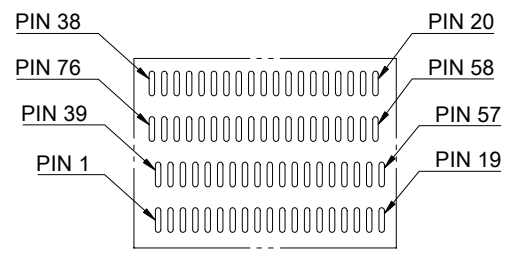

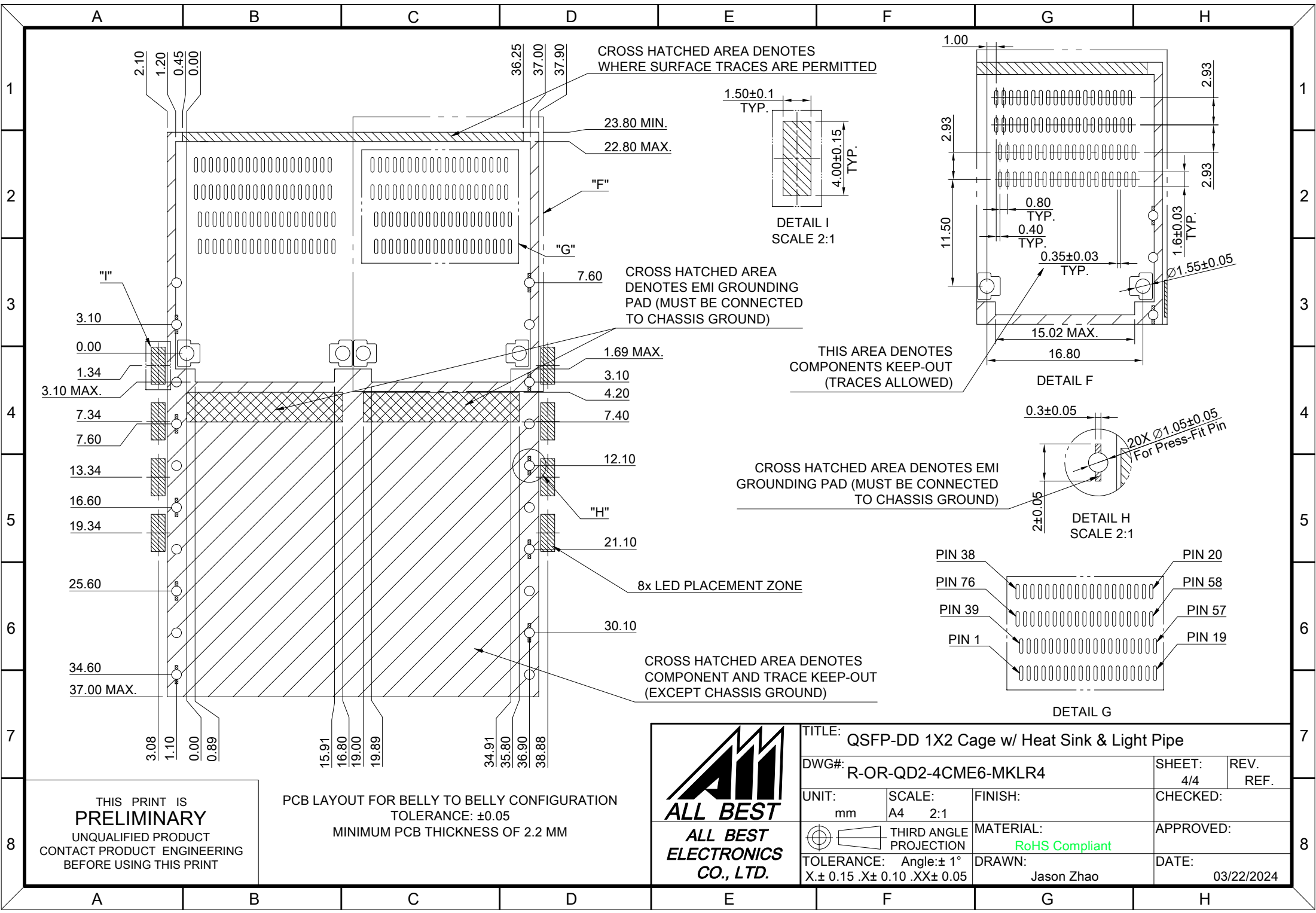

THIS PRINT IS
PRELIMINARY
UNQUALIFIED PRODUCT
CONTACT PRODUCT ENGINEERING
BEFORE USING THIS PRINT

PCB LAYOUT FOR BELLY TO BELLY CONFIGURATION
TOLERANCE: ±0.05
MINIMUM PCB THICKNESS OF 2.2 MM



TITLE: QSFP-DD 1X2 Cage w/ Heat Sink & Light Pipe			
DWG#: R-OR-QD2-4CME6-MKLR4		SHEET: 4/4	REV. REF.
UNIT: mm	SCALE: A4 2:1	FINISH:	CHECKED:
THIRD ANGLE PROJECTION		MATERIAL: RoHS Compliant	APPROVED:
TOLERANCE: Angle: ±1° X ± 0.15 .X ± 0.10 .XX ± 0.05		DRAWN: Jason Zhao	DATE: 03/22/2024

