

(20.52)

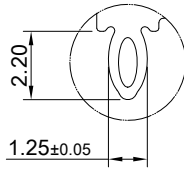

DETAIL A
SCALE 4:1

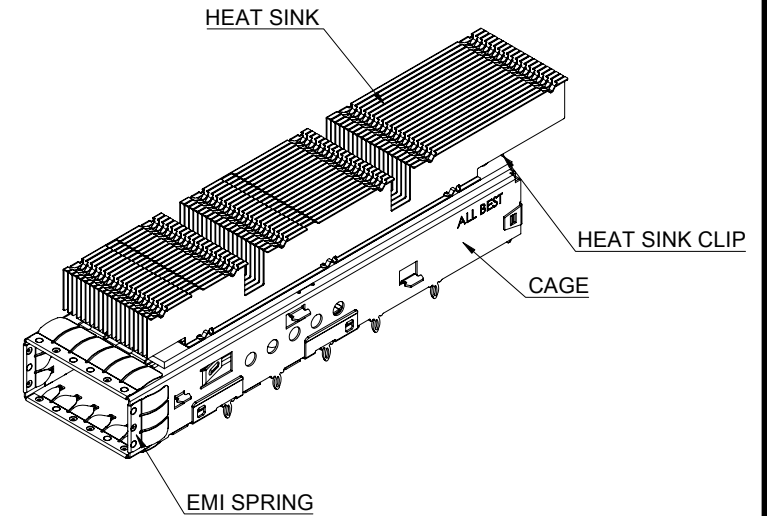

MATERIAL
 CAGE: NICKEL SILVER
 EMI SPRING: STAINLESS STEEL
 HEAT SINK: COPPER ALLOY
 HEAT SINK CLIP: STAINLESS STEEL

FINISH
 HEAT SINK: NICKEL OVER COPPER

NOTE
 ▲ DIMENSION APPLIES WITH MODULE INSERTED IN CAGE

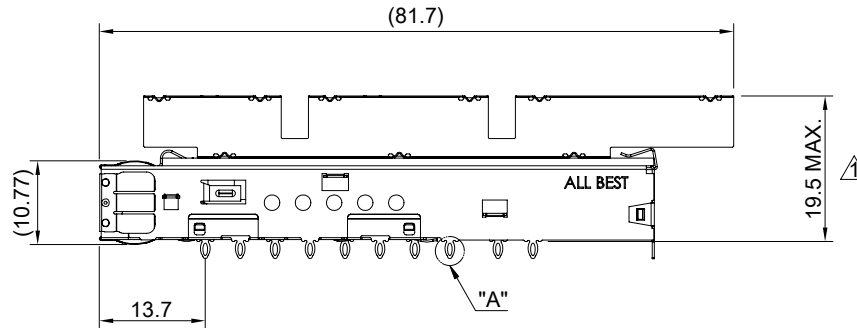
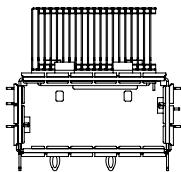

THIS PRINT IS
PRELIMINARY
 UNQUALIFIED PRODUCT
 CONTACT PRODUCT ENGINEERING
 BEFORE USING THIS PRINT



TITLE: QSFP-DD 800 1X1 Cage Assembly w/ Heat Sink			
DWG#: H-OR-DQD1-4CMFA3-TK		SHEET: 1/4	REV. REF.
UNIT: mm	SCALE: A4 1:1	CHECKED:	
TOLERANCE: Angle: ± 1° X.± 0.25 .X± 0.20 .XX± 0.15		MATERIAL: RoHS, HF Compliant	APPROVED:
THIRD ANGLE PROJECTION		DRAWN: Jason Zhao	DATE: 03/22/2024

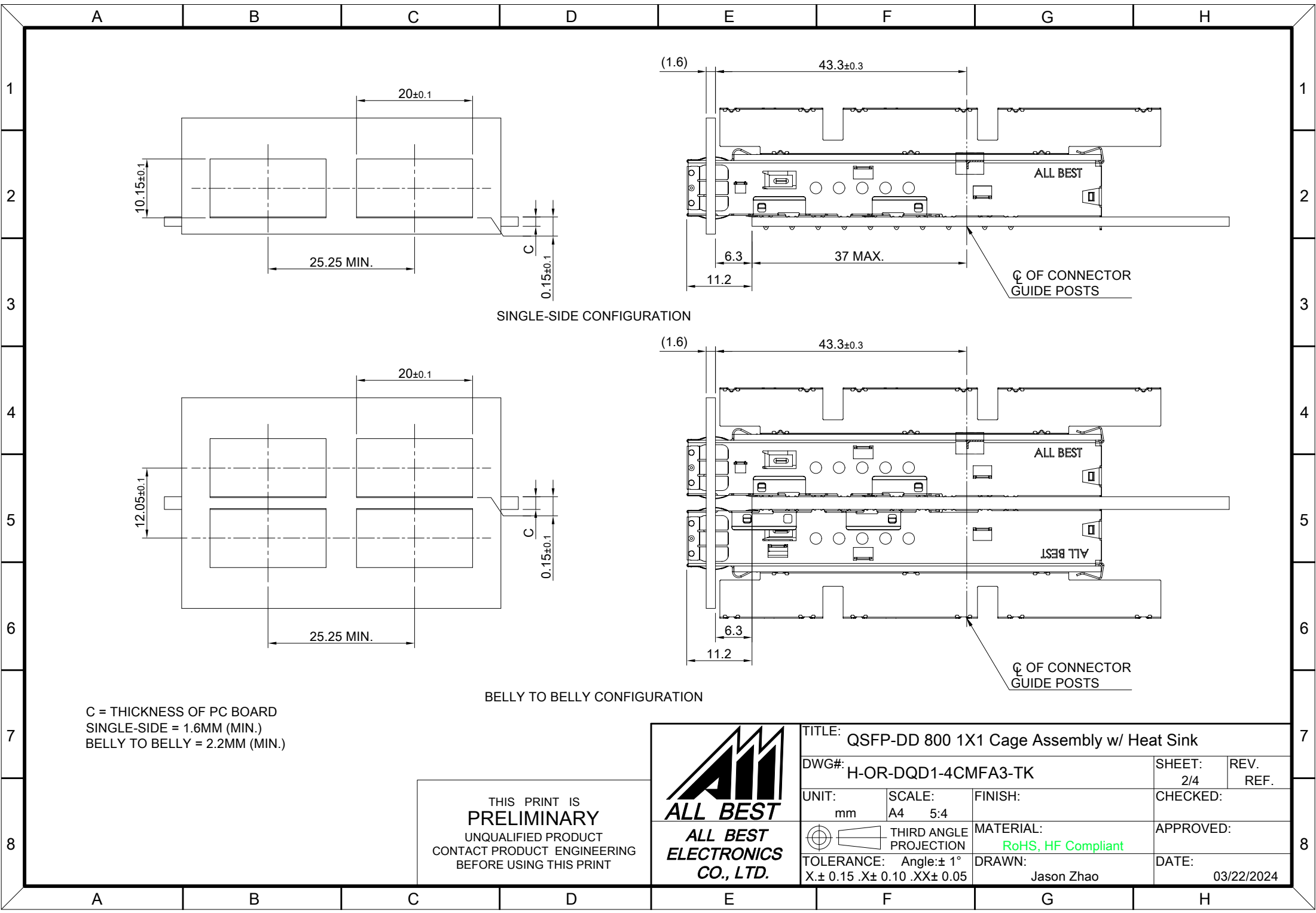

SINGLE-SIDE CONFIGURATION

BELLY TO BELLY CONFIGURATION

C = THICKNESS OF PC BOARD
 SINGLE-SIDE = 1.6MM (MIN.)
 BELLY TO BELLY = 2.2MM (MIN.)

THIS PRINT IS
PRELIMINARY
 UNQUALIFIED PRODUCT
 CONTACT PRODUCT ENGINEERING
 BEFORE USING THIS PRINT



TITLE: QSFP-DD 800 1X1 Cage Assembly w/ Heat Sink			
DWG#: H-OR-DQD1-4CMFA3-TK		SHEET: 2/4	REV. REF.
UNIT: mm	SCALE: A4 5:4	FINISH:	CHECKED:
THIRD ANGLE PROJECTION		MATERIAL: RoHS, HF Compliant	APPROVED:
TOLERANCE: Angle: ± 1° X ± 0.15 .X ± 0.10 .XX ± 0.05		DRAWN: Jason Zhao	DATE: 03/22/2024

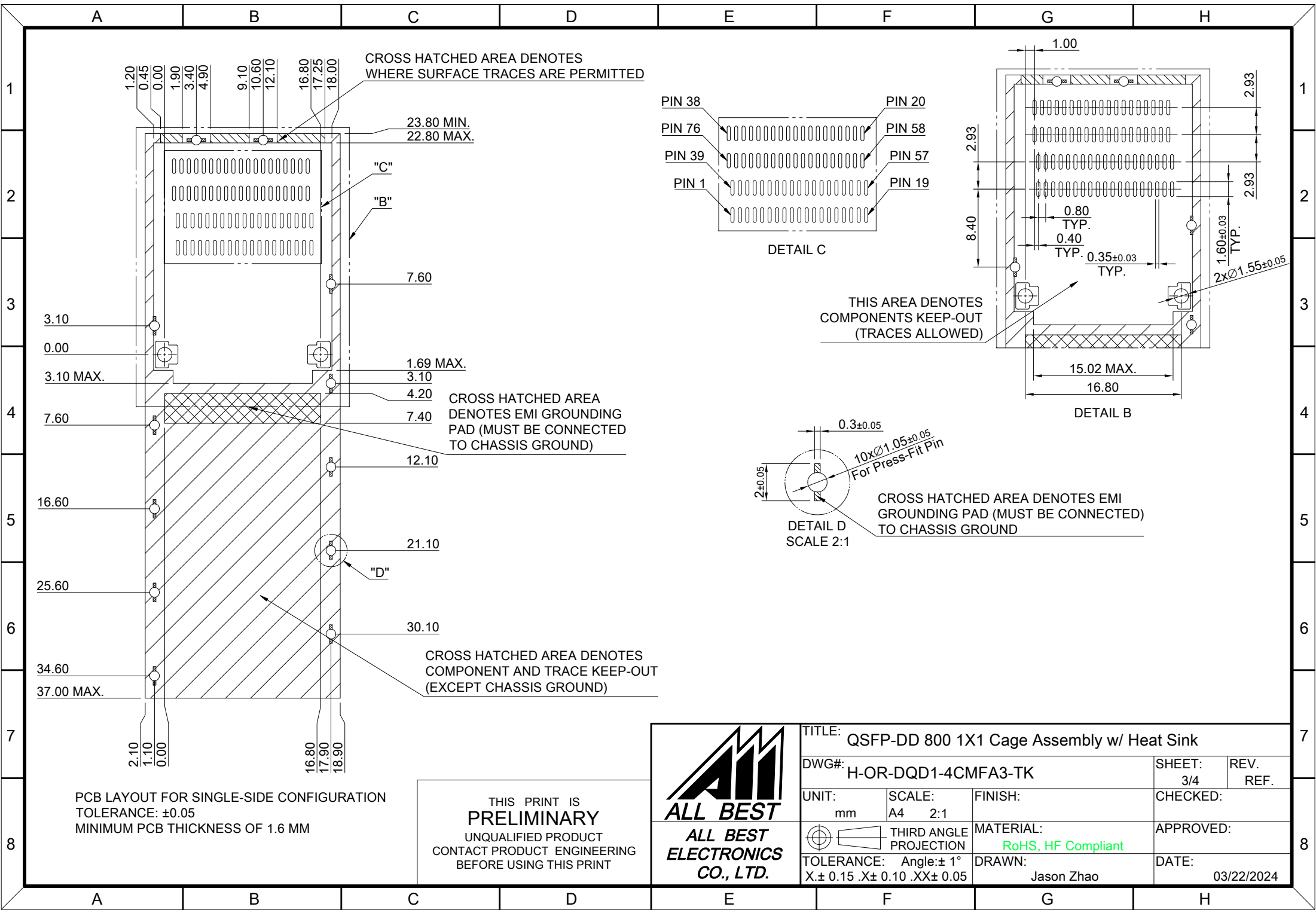

TITLE: QSFP-DD 800 1X1 Cage Assembly w/ Heat Sink			
DWG#: H-OR-DQD1-4CMFA3-TK		SHEET: 3/4	REV. REF.
UNIT: mm	SCALE: A4 2:1	CHECKED:	
THIRD ANGLE PROJECTION		MATERIAL: RoHS, HF Compliant	APPROVED:
TOLERANCE: Angle: $\pm 1^\circ$ X: ± 0.15 .X: ± 0.10 .XX: ± 0.05		DRAWN: Jason Zhao	DATE: 03/22/2024

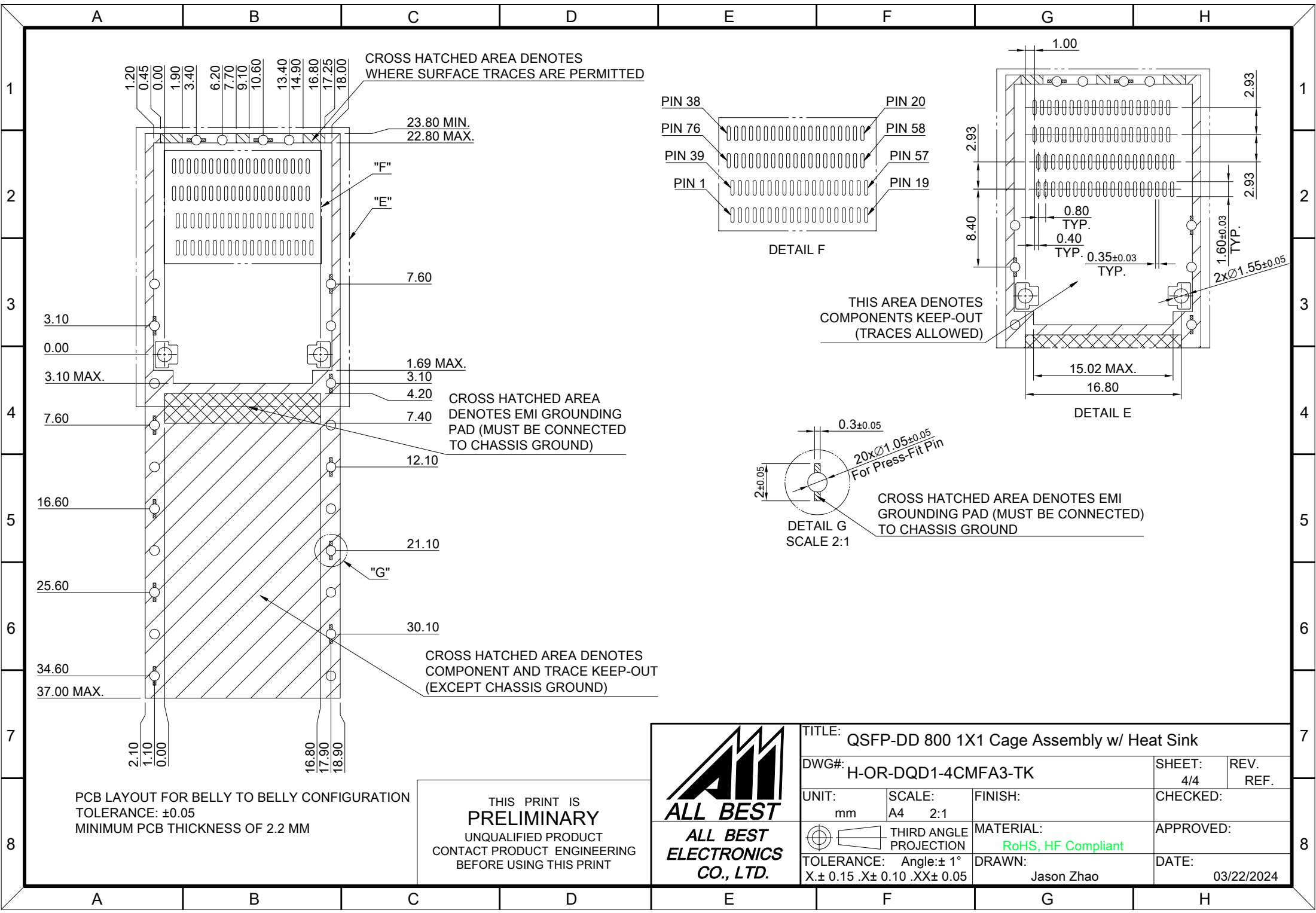

PCB LAYOUT FOR BELLY TO BELLY CONFIGURATION
 TOLERANCE: ±0.05
 MINIMUM PCB THICKNESS OF 2.2 MM

THIS PRINT IS
PRELIMINARY
 UNQUALIFIED PRODUCT
 CONTACT PRODUCT ENGINEERING
 BEFORE USING THIS PRINT



TITLE: QSFP-DD 800 1X1 Cage Assembly w/ Heat Sink			
DWG#: H-OR-DQD1-4CMFA3-TK		SHEET: 4/4	REV. REF.
UNIT: mm	SCALE: A4 2:1	FINISH:	CHECKED:
THIRD ANGLE PROJECTION		MATERIAL: RoHS, HF Compliant	APPROVED:
TOLERANCE: X±0.15 .X±0.10 .XX±0.05		DRAWN: Jason Zhao	DATE: 03/22/2024