

DETAIL A
SCALE 4:1

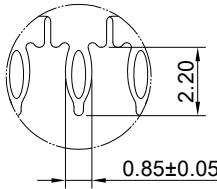

DETAIL B
SCALE 4:1

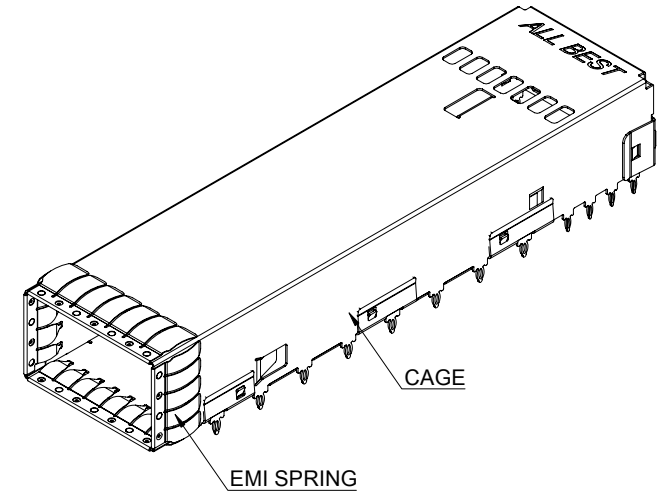
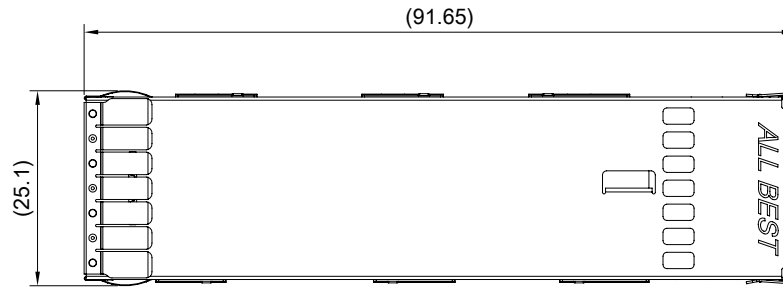

MATERIAL
CAGE: NICKEL SILVER
EMI SPRING: STAINLESS STEEL

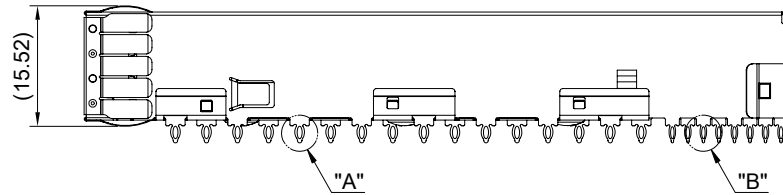
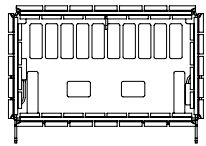

THIS PRINT IS
PRELIMINARY
UNQUALIFIED PRODUCT
CONTACT PRODUCT ENGINEERING
BEFORE USING THIS PRINT



TITLE: OSFP 1600 1X1 Cage Assembly			
DWG#: H-OR-QOS1-4CMX1		SHEET: 1/4	REV. REF.
UNIT: mm	SCALE: A4 1:1	FINISH:	CHECKED:
TOLERANCE: Angle: ± 1° X.± 0.25 .X± 0.20 .XX± 0.15		MATERIAL: RoHS, HF Compliant	APPROVED:
THIRD ANGLE PROJECTION		DRAWN: Jason Zhao	DATE: 03/25/2024

A B C D E F G H

1
2
3
4
5
6
7
8

1
2
3
4
5
6
7
8

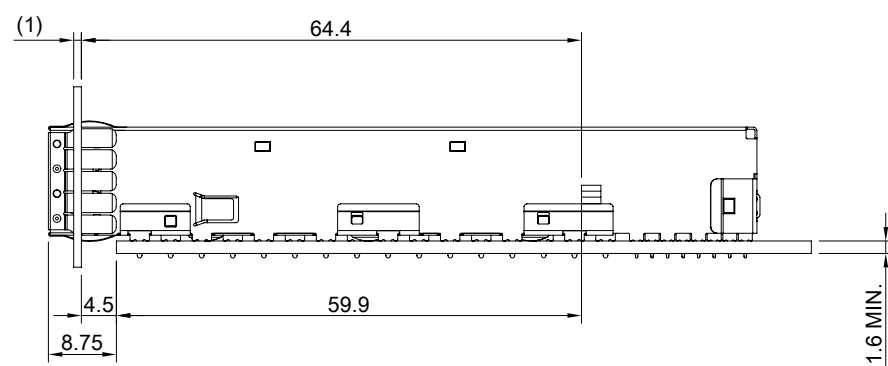
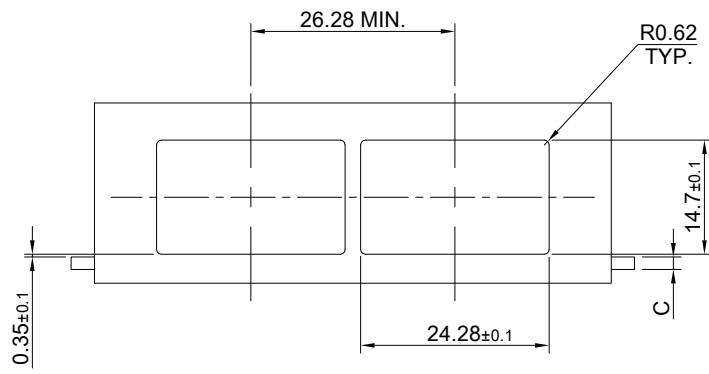

SINGLE-SIDE CONFIGURATION

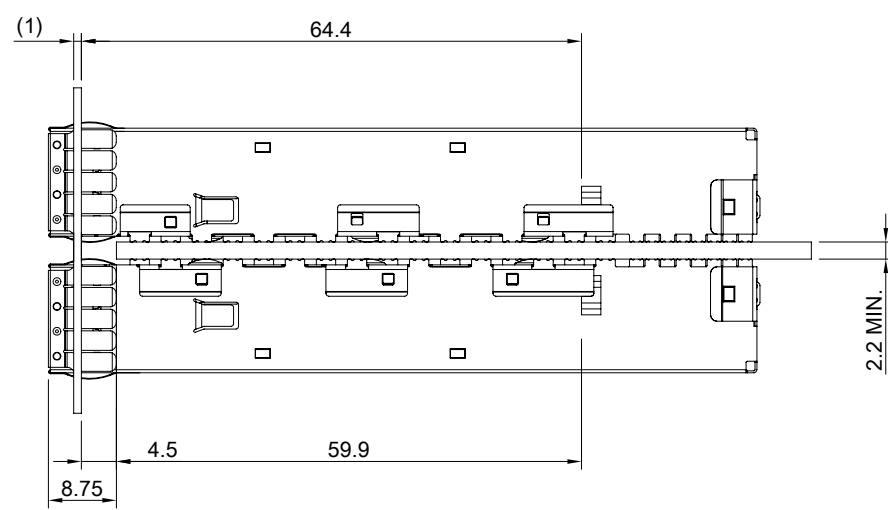
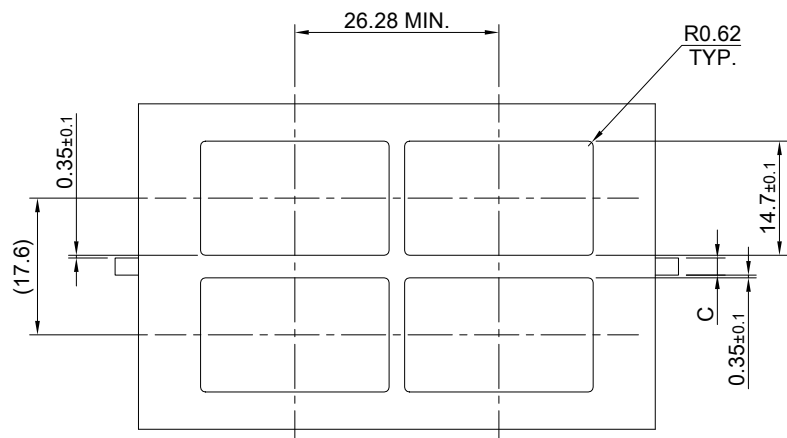

BELLY TO BELLY CONFIGURATION

C = THICKNESS OF PC BOARD
 SINGLE-SIDE = 1.6 MM (MIN.)
 BELLY TO BELLY = 2.2MM (MIN.)

THIS PRINT IS
PRELIMINARY
 UNQUALIFIED PRODUCT
 CONTACT PRODUCT ENGINEERING
 BEFORE USING THIS PRINT



TITLE: OSFP 1600 1X1 Cage Assembly			
DWG#: H-OR-QOS1-4CMX1		SHEET: 2/4	REV. REF.
UNIT: mm	SCALE: A4 1:1	CHECKED:	
TOLERANCE: X±0.15 .X±0.10 .XX±0.05		MATERIAL: RoHS, HF Compliant	APPROVED:
THIRD ANGLE PROJECTION		DRAWN: Jason Zhao	DATE: 03/25/2024

A B C D E F G H

OPTIONAL SOLDER RING FOR SMT
BELLY TO BELLY APPLICATION
COMPONENT KEEP-OUT AND SURFACE TRACE
KEEP-OUT (2 PLACES)

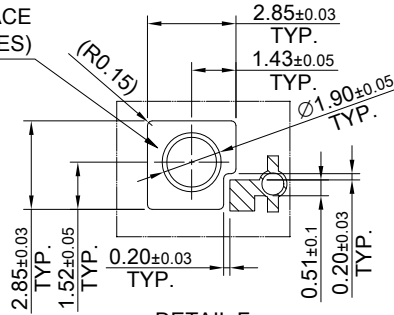

DETAIL F
SCALE 4:1

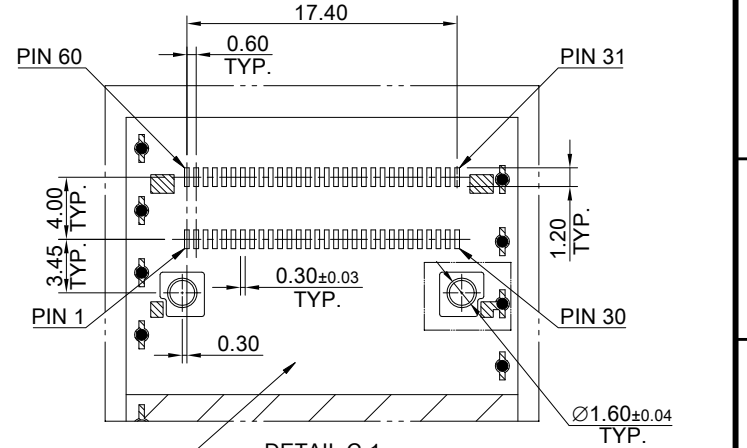

DETAIL C-1
SCALE 2:1

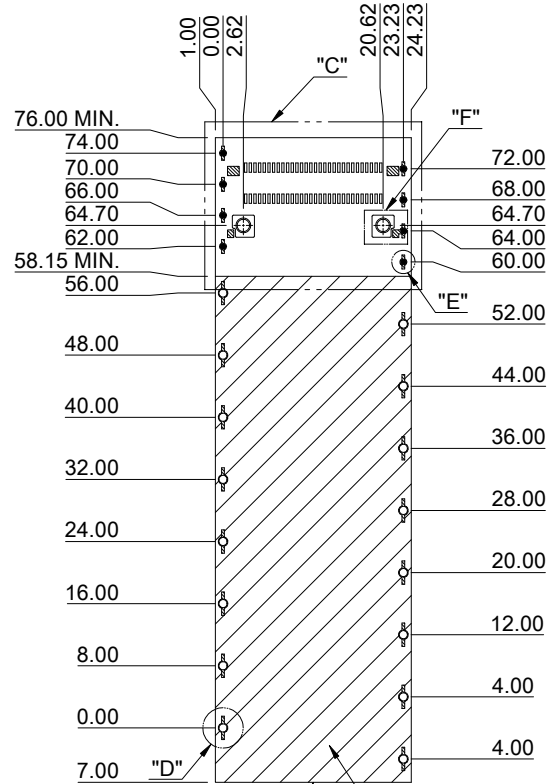

EDGE OF THE HOST PCB

CROSS HATCHED AREA DENOTES
COMPONENT AND TRACE KEEP-OUT
(EXCEPT CHASSIS GROUND)

RECOMMENDED PCB LAYOUT
TOLERANCE: ± 0.05

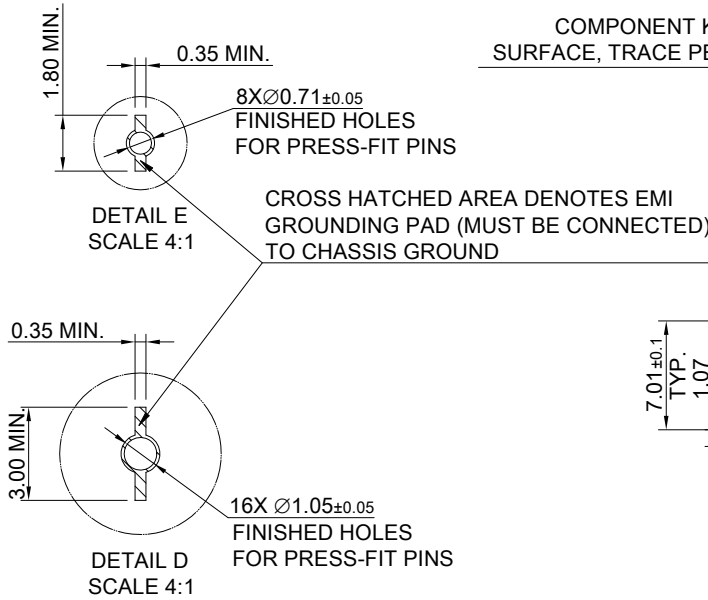

DETAIL E
SCALE 4:1

DETAIL D
SCALE 4:1

CROSS HATCHED AREA DENOTES EMI
GROUNDING PAD (MUST BE CONNECTED)
TO CHASSIS GROUND

KEEP-OUT ZONE IN HATCHED AREAS (4 PLACES)
NO TRACE OR INK MARKING ALLOWED

COMPONENT KEEP-OUT
SURFACE, TRACE PERMITTED

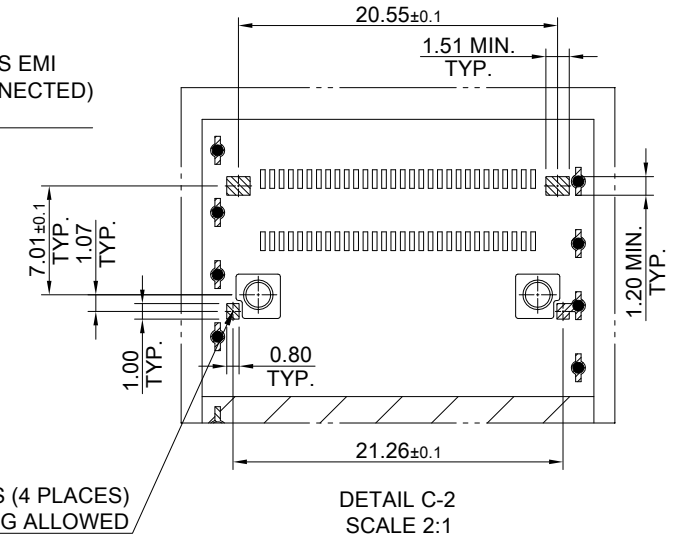

DETAIL C-2
SCALE 2:1

THIS PRINT IS
PRELIMINARY
UNQUALIFIED PRODUCT
CONTACT PRODUCT ENGINEERING
BEFORE USING THIS PRINT



TITLE: OSFP 1600 1X1 Cage Assembly

DWG#: H-OR-QOS1-4CMX1

UNIT: mm SCALE: A4 1:1

THIRD ANGLE PROJECTION

TOLERANCE: Angle: $\pm 1^\circ$
X: ± 0.15 .X: ± 0.10 .XX: ± 0.05

FINISH:

MATERIAL: RoHS, HF Compliant

DRAWN: Jason Zhao

SHEET: 3/4 REV. REF.

CHECKED:

APPROVED:

DATE: 03/25/2024

OPTIONAL SOLDER RING FOR SMT
BELLY TO BELLY APPLICATION
COMPONENT KEEP-OUT AND SURFACE TRACE
KEEP-OUT (2 PLACES)

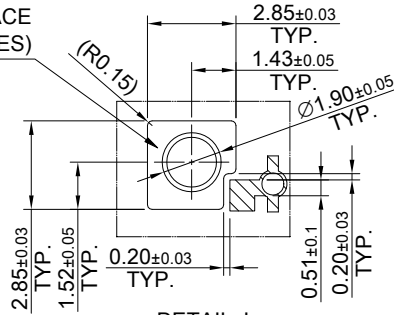

DETAIL J
SCALE 4:1

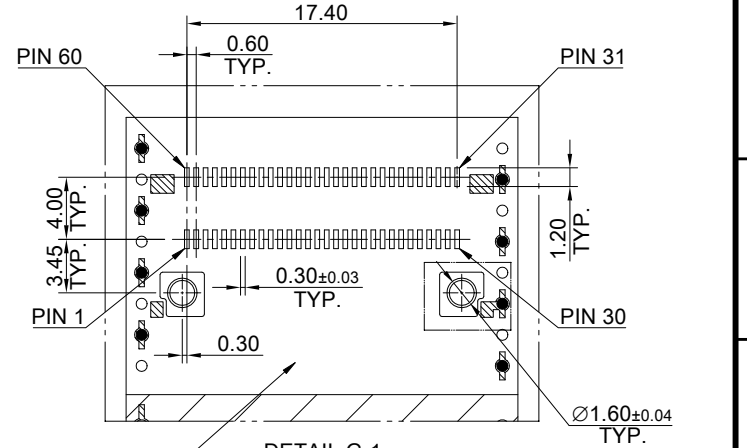

DETAIL G-1
SCALE 2:1

NON-PLATED HOLE

COMPONENT KEEP-OUT
SURFACE, TRACE PERMITTED

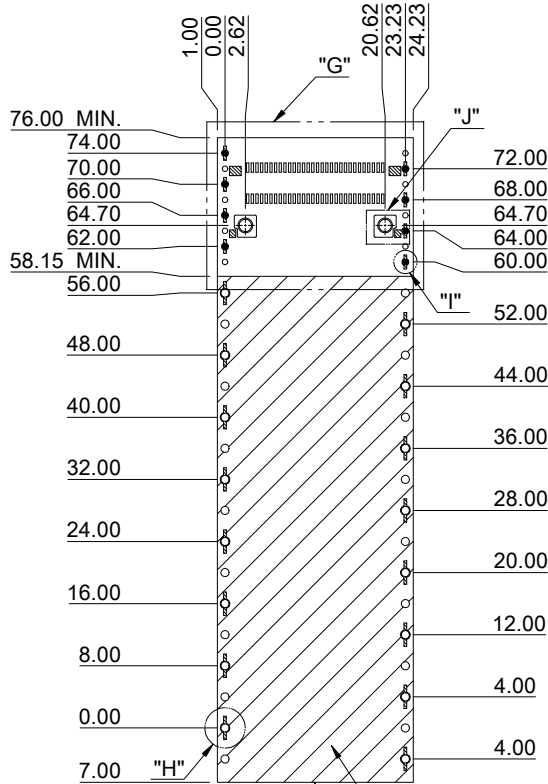

EDGE OF THE HOST PCB

CROSS HATCHED AREA DENOTES
COMPONENT AND TRACE KEEP-OUT
(EXCEPT CHASSIS GROUND)

RECOMMENDED PCB LAYOUT
TOLERANCE: ± 0.05

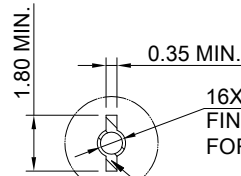

DETAIL I
SCALE 4:1

CROSS HATCHED AREA DENOTES EMI
GROUNDING PAD (MUST BE CONNECTED)
TO CHASSIS GROUND

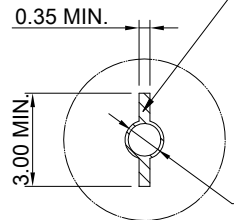

DETAIL H
SCALE 4:1

KEEP-OUT ZONE IN HATCHED AREAS (4 PLACES)
NO TRACE OR INK MARKING ALLOWED

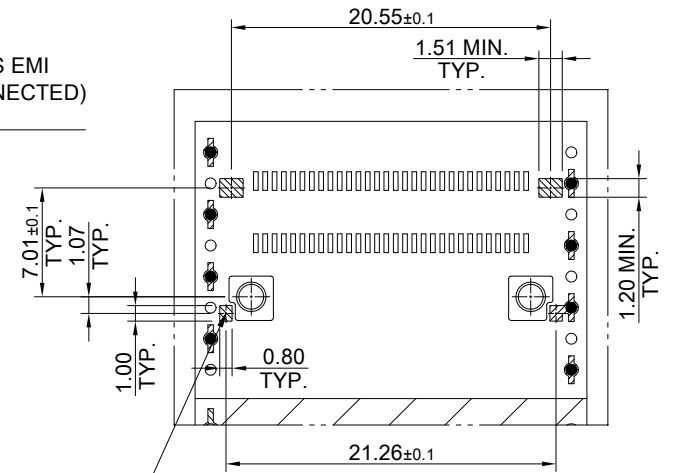

DETAIL G-2
SCALE 2:1

THIS PRINT IS
PRELIMINARY
UNQUALIFIED PRODUCT
CONTACT PRODUCT ENGINEERING
BEFORE USING THIS PRINT



TITLE: OSFP 1600 1X1 Cage Assembly

DWG#: H-OR-QOS1-4CMX1

SHEET: 4/4
REV. REF.

UNIT: mm
SCALE: A4 1:1

FINISH: CHECKED:

THIRD ANGLE PROJECTION

MATERIAL: RoHS, HF Compliant
APPROVED:

TOLERANCE: Angle: $\pm 1^\circ$
X: ± 0.15 .X: ± 0.10 .XX: ± 0.05

DRAWN: Jason Zhao
DATE: 03/25/2024