

DETAIL A  
SCALE 4:1

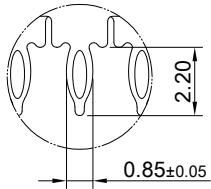

DETAIL B  
SCALE 4:1

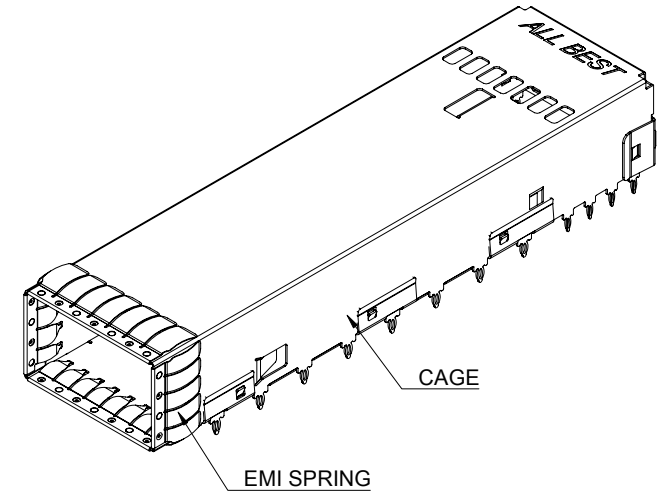
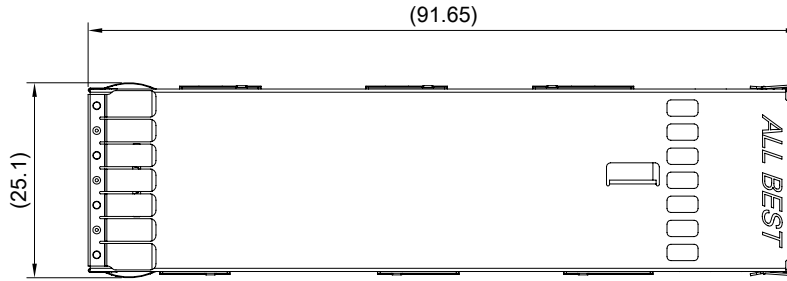

MATERIAL  
CAGE: NICKEL SILVER  
EMI SPRING: STAINLESS STEEL

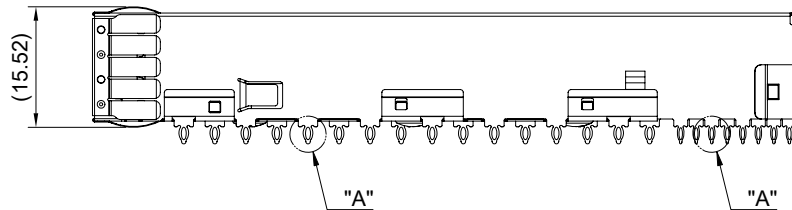
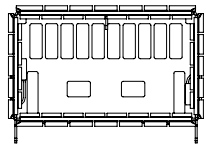

THIS PRINT IS  
**PRELIMINARY**  
UNQUALIFIED PRODUCT  
CONTACT PRODUCT ENGINEERING  
BEFORE USING THIS PRINT



TITLE: OSFP 800 1X1 Cage Assembly			
DWG#: H-OR-DOS1-4CMX1		SHEET: 1/4	REV. REF.
UNIT: mm	SCALE: A4 1:1	FINISH:	CHECKED:
TOLERANCE: Angle: ± 1° X.± 0.25 .X± 0.20 .XX± 0.15		MATERIAL: RoHS, HF Compliant	APPROVED:
THIRD ANGLE PROJECTION		DRAWN: Jason Zhao	DATE: 03/21/2024

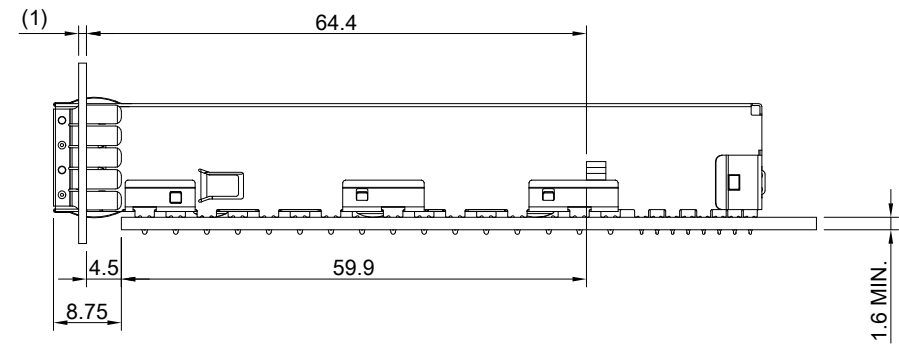
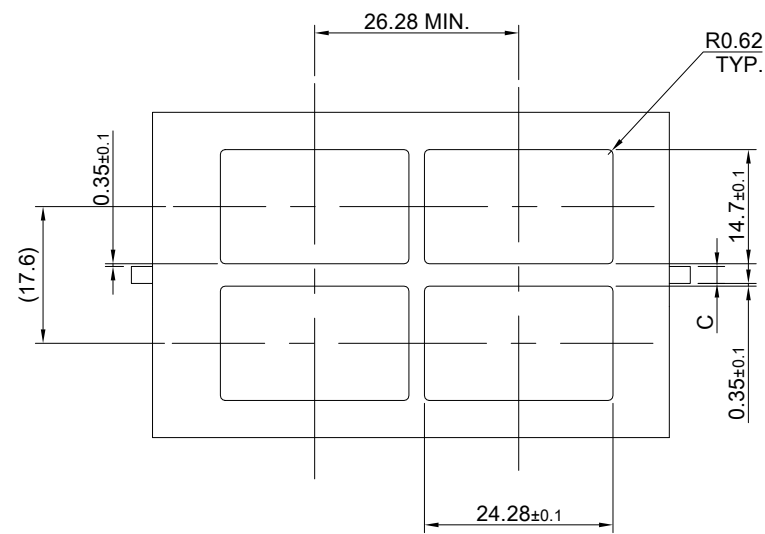
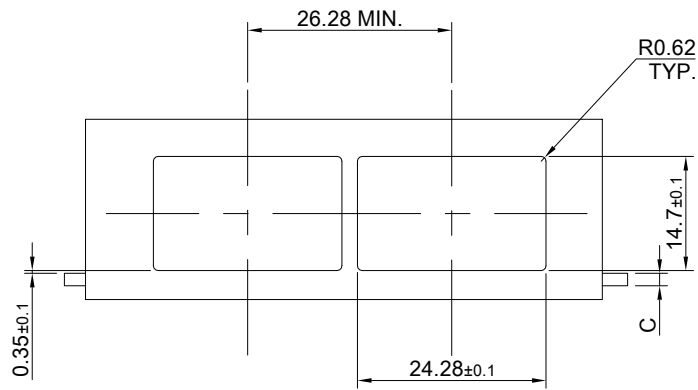

SINGLE-SIDE CONFIGURATION

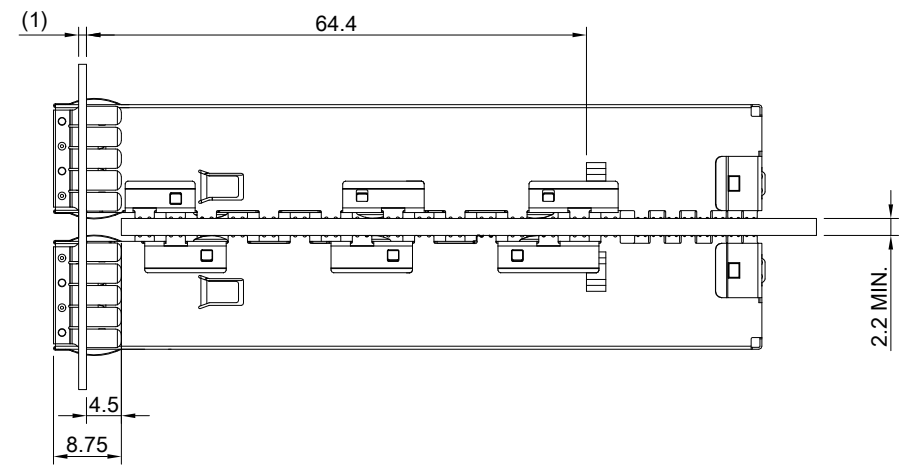

BELLY TO BELLY CONFIGURATION

C = THICKNESS OF PC BOARD  
 SINGLE-SIDE = 1.6 MM (MIN.)  
 BELLY TO BELLY = 2.2MM (MIN.)

THIS PRINT IS  
**PRELIMINARY**  
 UNQUALIFIED PRODUCT  
 CONTACT PRODUCT ENGINEERING  
 BEFORE USING THIS PRINT



TITLE: OSFP 800 1X1 Cage Assembly			
DWG#: H-OR-DOS1-4CMX1		SHEET: 2/4	REV. REF.
UNIT: mm	SCALE: A4 1:1	CHECKED:	
TOLERANCE: Angle: ± 1° X ± 0.15 .X ± 0.10 .XX ± 0.05		MATERIAL: RoHS, HF Compliant	APPROVED:
THIRD ANGLE PROJECTION		DRAWN: Jason Zhao	DATE: 03/21/2024

OPTIONAL SOLDER RING FOR SMT BELLY TO BELLY APPLICATION  
COMPONENT KEEP-OUT AND SURFACE TRACE KEEP-OUT (2 PLACES)

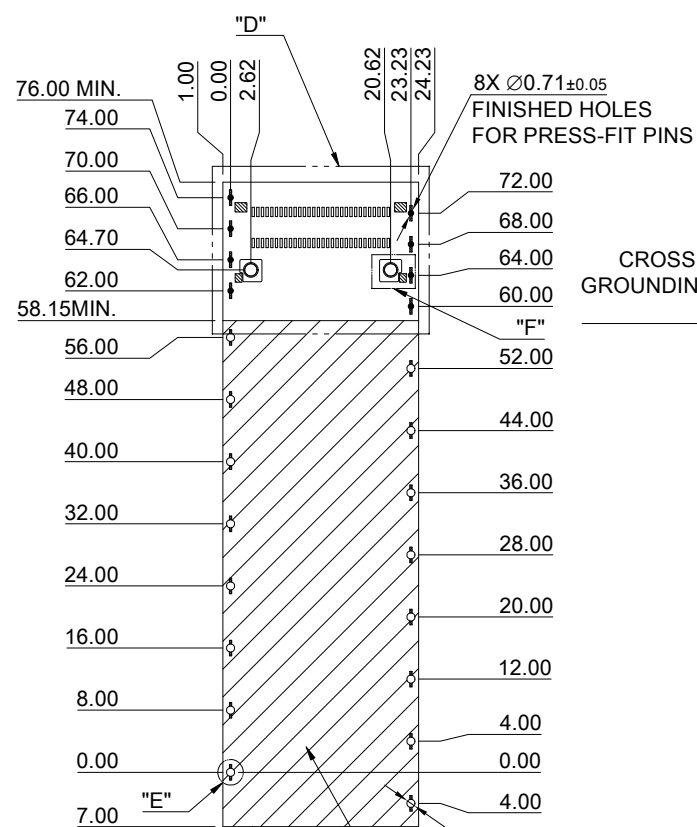
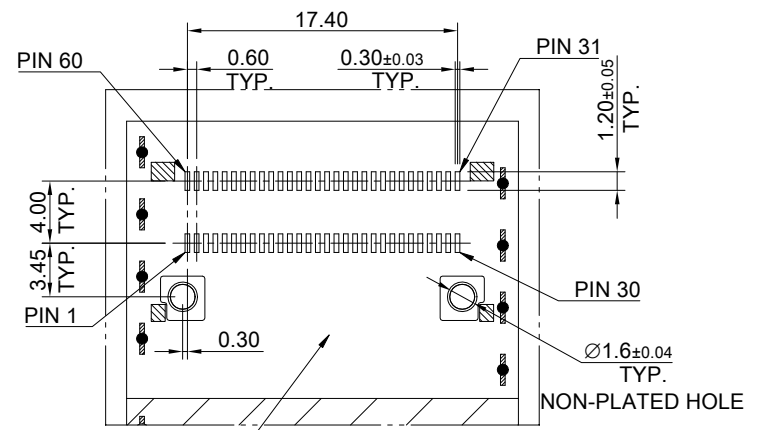
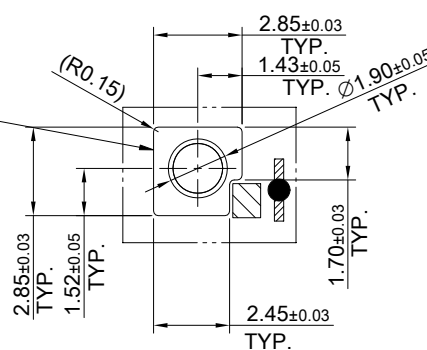

CROSS HATCHED AREA DENOTES EMI GROUNDING PAD (MUST BE CONNECTED) TO CHASSIS GROUND

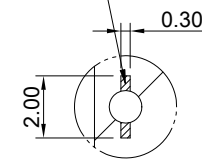

KEEP-OUT ZONE IN HATCHED AREAS (4 PLACES)  
NO TRACE OR INK MARKING ALLOWED

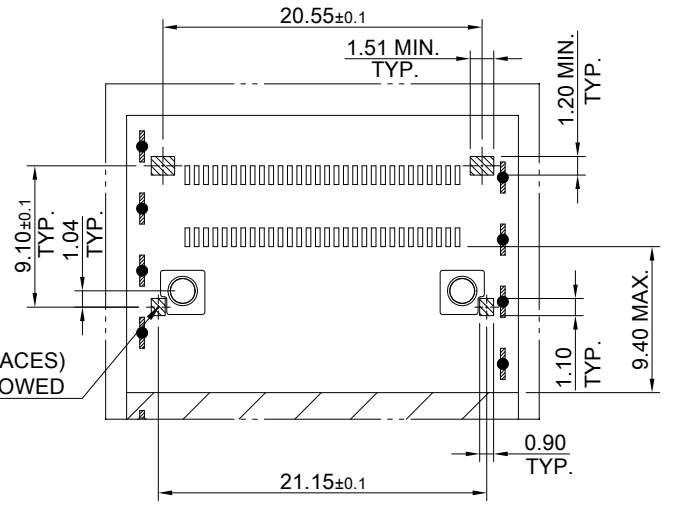

CROSS HATCHED AREA DENOTES COMPONENT AND TRACE KEEP-OUT (EXCEPT CHASSIS GROUND)

RECOMMENDED PCB LAYOUT  
TOLERANCE: ±0.05

THIS PRINT IS  
**PRELIMINARY**  
UNQUALIFIED PRODUCT  
CONTACT PRODUCT ENGINEERING  
BEFORE USING THIS PRINT



TITLE: OSFP 800 1X1 Cage Assembly			
DWG#: H-OR-DOS1-4CMX1		SHEET: 3/4	REV. REF.
UNIT: mm	SCALE: A4 1:1	CHECKED:	
THIRD ANGLE PROJECTION		APPROVED:	
TOLERANCE: Angle: ±1°		MATERIAL: RoHS, HF Compliant	DATE: 03/21/2024
X.± 0.15 .X± 0.10 .XX± 0.05		DRAWN: Jason Zhao	

OPTIONAL SOLDER RING FOR SMT BELLY TO BELLY APPLICATION  
COMPONENT KEEP-OUT AND SURFACE TRACE KEEP-OUT (2 PLACES)

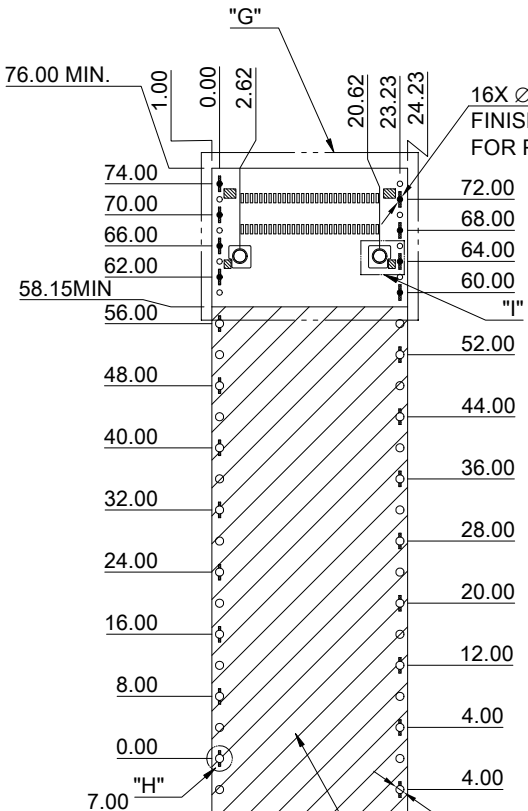
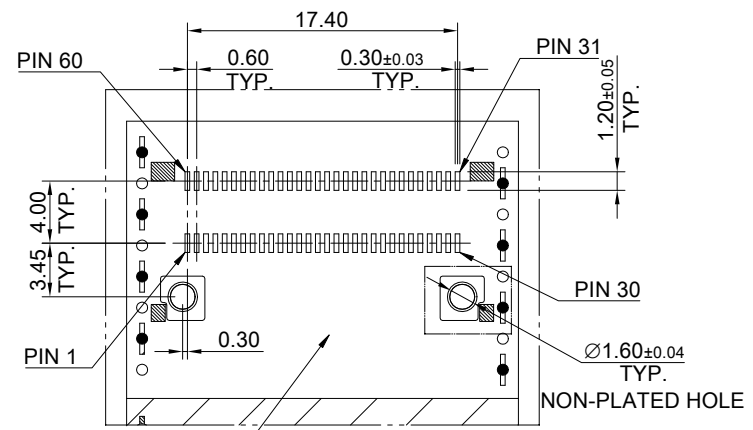
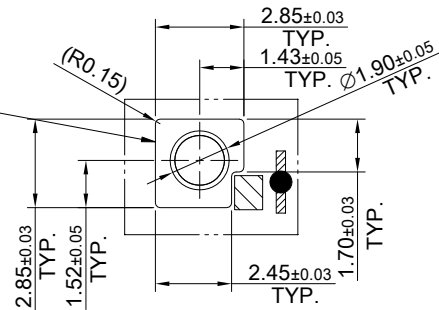

16X  $\varnothing 0.71 \pm 0.05$  FINISHED HOLES FOR PRESS-FIT PINS

CROSS HATCHED AREA DENOTES EMI GROUNDING PAD (MUST BE CONNECTED TO CHASSIS GROUND)

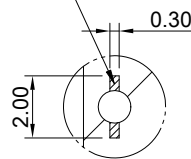

KEEP-OUT ZONE IN HATCHED AREAS (4 PLACES) NO TRACE OR INK MARKING ALLOWED

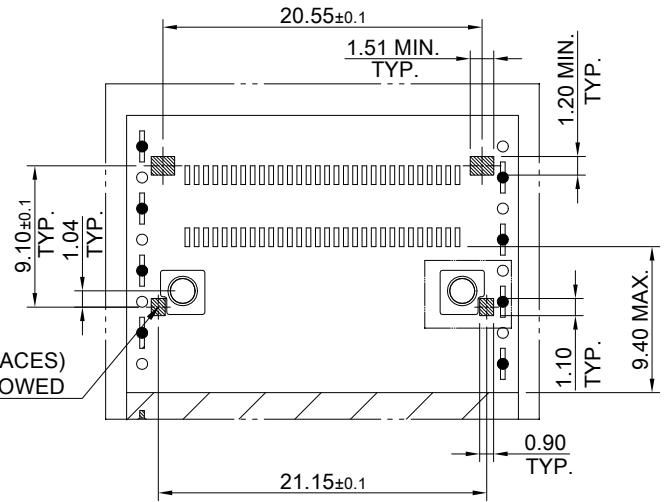

32X  $\varnothing 1.05 \pm 0.05$  FINISHED HOLES FOR PRESS-FIT PINS

CROSS HATCHED AREA DENOTES COMPONENT AND TRACE KEEP-OUT (EXCEPT CHASSIS GROUND)

RECOMMENDED PCB LAYOUT TOLERANCE:  $\pm 0.05$

THIS PRINT IS PRELIMINARY  
UNQUALIFIED PRODUCT  
CONTACT PRODUCT ENGINEERING  
BEFORE USING THIS PRINT



TITLE: OSFP 800 1X1 Cage Assembly			
DWG#: H-OR-DOS1-4CMX1		SHEET: 4/4	REV. REF.
UNIT: mm	SCALE: A4 1:1	CHECKED:	
THIRD ANGLE PROJECTION		APPROVED:	
TOLERANCE: Angle: $\pm 1^\circ$		MATERIAL: RoHS, HF Compliant	DATE: 03/21/2024
X. $\pm 0.15$ .X $\pm 0.10$ .XX $\pm 0.05$		DRAWN: Jason Zhao	