

MATERIAL  
 CONTACTS: COPPER ALLOY  
 INSULATOR: LCP THERMOPLASTIC 94V-0  
 WELD TAB: COPPER ALLOY

FINISH  
 CONTACTS: 5µ" MIN. GOLD ON MATING END;  
 MATTE TIN ON SOLDER  
 ALL UNDERPLATED NICKEL  
 WELD TAB: MATTE TIN

ELECTRICAL  
 CONTACT CURRENT RATING: 2 AMPERE  
 VOLTAGE RATING: 275VAC  
 MAX CYCLES: 25

ENVIRONMENT  
 OPERATION TEMPERATURE: -55°C TO 125°C  
 SMT TEMPERATURE: 260°C

THIS PRINT IS  
**PRELIMINARY**  
 UNQUALIFIED PRODUCT  
 CONTACT PRODUCT ENGINEERING  
 BEFORE USING THIS PRINT



TITLE: COM-HPC 400pin Male Connector w/ Weld Tab

DWG#: R-CM-HPC400-8AW2

UNIT: mm

SCALE: A4 5:4

FINISH:

SHEET: 1/3  
 REV. REF2

THIRD ANGLE PROJECTION

MATERIAL: **RoHS Compliant**

APPROVED:

TOLERANCE: Angle: ± 1°  
 X: ± 0.25 .X: ± 0.20 .XX: ± 0.15

DRAWN: Ting

DATE: 03/22/2024

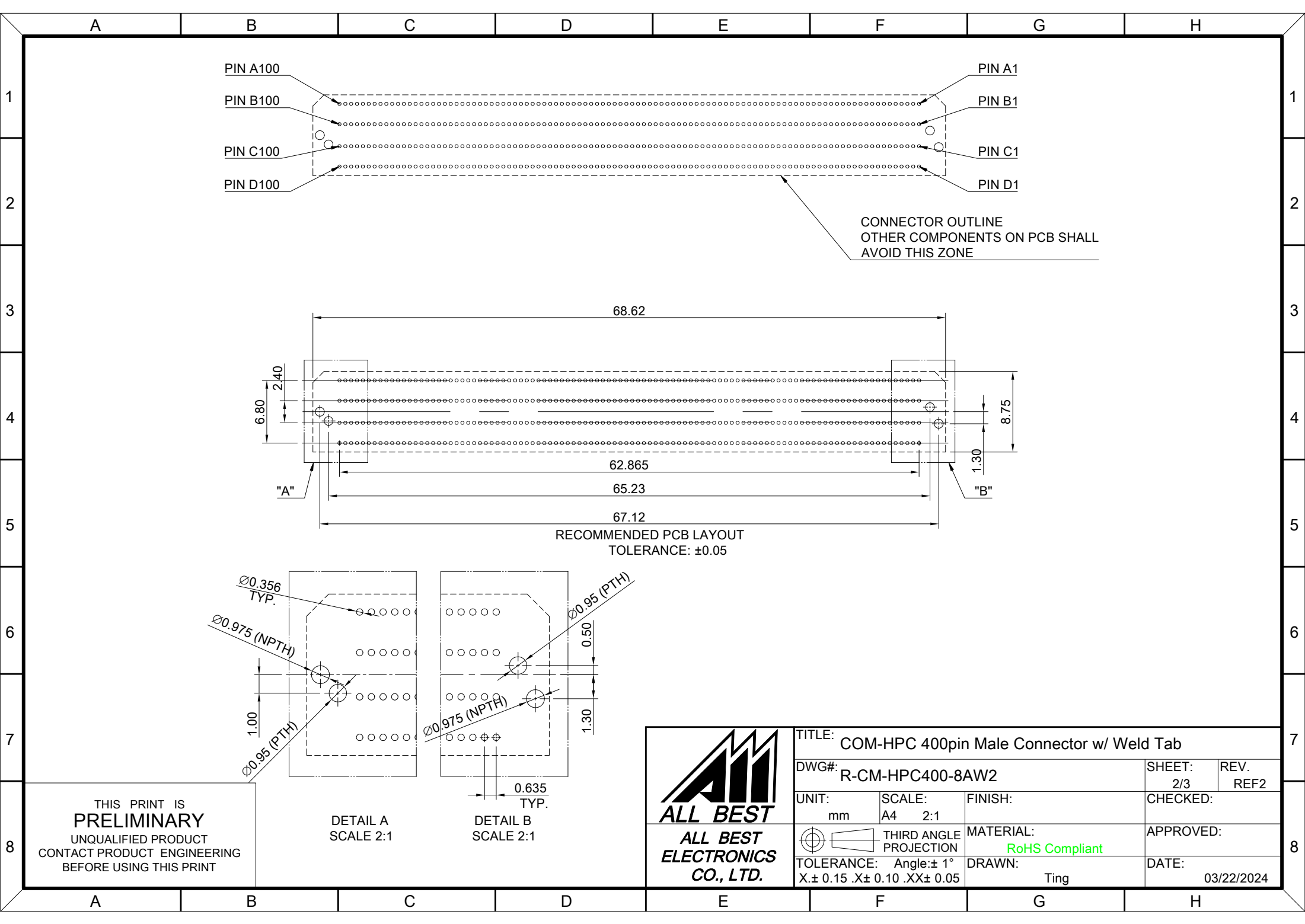

THIS PRINT IS  
**PRELIMINARY**  
 UNQUALIFIED PRODUCT  
 CONTACT PRODUCT ENGINEERING  
 BEFORE USING THIS PRINT



TITLE: COM-HPC 40pin Male Connector w/ Weld Tab			
DWG#: R-CM-HPC400-8AW2		SHEET: 2/3	REV. REF2
UNIT: mm	SCALE: A4 2:1	FINISH:	CHECKED:
TOLERANCE: $X \pm 0.15$ .X $\pm 0.10$ .XX $\pm 0.05$		MATERIAL: RoHS Compliant	APPROVED:
THIRD ANGLE PROJECTION		DRAWN: Ting	DATE: 03/22/2024

FEMALE: R-CF-HPC400-8AW1

MALE: SEE TYPE

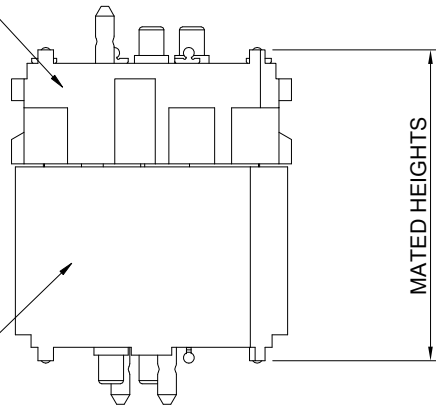

TYPE	MATED HEIGHTS
R-CM-HPC400-8AW1	5mm
R-CM-HPC400-8AW2	10mm

NOTE: Processing conditions will affect mated height.

PROCESSING VIEW  
 DIMENSION INDICATES CONNECTOR/FIXTURE HEIGHT ON PCB  
 TO GUARANTEE ENOUGH REFLOW OVEN WORKING SPACE.  
 DIMENSION, PCB THICKNESS, AND THE HEIGHT OF THE COMPONENTS  
 ON THE OTHER SIDE OF THE BOARD NEED TO BE CONSIDERED.

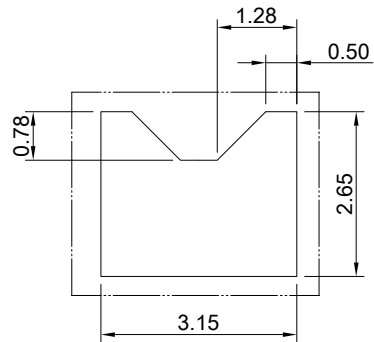

DETAIL C  
 SCALE 2:1



RECOMMENDED STENCIL LAYOUT  
 ALL DIMENSIONS SYMMETRIC ABOUT CENTERLINE  
 STENCIL TO BE 0.125mm THICK

THIS PRINT IS  
**PRELIMINARY**  
 UNQUALIFIED PRODUCT  
 CONTACT PRODUCT ENGINEERING  
 BEFORE USING THIS PRINT



TITLE: COM-HPC 400pin Male Connector w/ Weld Tab

DWG#: R-CM-HPC400-8AW2

SHEET: 3/3  
 REV. REF2

UNIT: mm  
 SCALE: A4 4:1

FINISH: CHECKED:

THIRD ANGLE PROJECTION

MATERIAL: RoHS Compliant

APPROVED:

TOLERANCE: Angle: ± 1°  
 X: ± 0.15 .X: ± 0.10 .XX: ± 0.05

DRAWN: Ting

DATE: 03/22/2024