

MATERIAL
 CAGE: NICKEL SILVER
 CONNECTOR: LCP 94V-0
 COPPER ALLOY
 EMI SPRING: STAINLESS STEEL
 LIGHT PIPE: PC (CLEAR)

FINISH
 CONTACT: 15µ" MIN. GOLD ON MATING END;
 30µ" MIN. MATTE TIN ON TERMINATION END;
 ALL UNDERPLATED 50µ" MIN. NICKEL

ELECTRICAL CHARACTERISTICS
 CONTACT CURRENT RATING: 0.5 AMPERE
 VOLTAGE RATING: 30 VAC
 CONTACT RESISTANCE: 80 mΩ MAX.
 DIELECTRIC WITHSTANDING VOLTAGE: 300VAC

THIS PRINT IS
PRELIMINARY
 UNQUALIFIED PRODUCT
 CONTACT PRODUCT ENGINEERING
 BEFORE USING THIS PRINT

<p>ALL BEST ELECTRONICS CO., LTD.</p>	TITLE: Stacked SFP+ 2X8 ASS'Y w/ Internal Thermal Solution & Light Pipe		SHEET: 1/3		REV. REF	
	DWG#: R-OP-008320-7P-F-N2-58		CHECKED:		APPROVED:	
	UNIT: mm	SCALE: A4 2:3	FINISH:		DATE: 03/28/2024	
	TOLERANCE: Angle: ± 1° X.± 0.25 .X± 0.20 .XX± 0.15		THIRD ANGLE PROJECTION	MATERIAL: RoHS Compliant		DRAWN: Laura

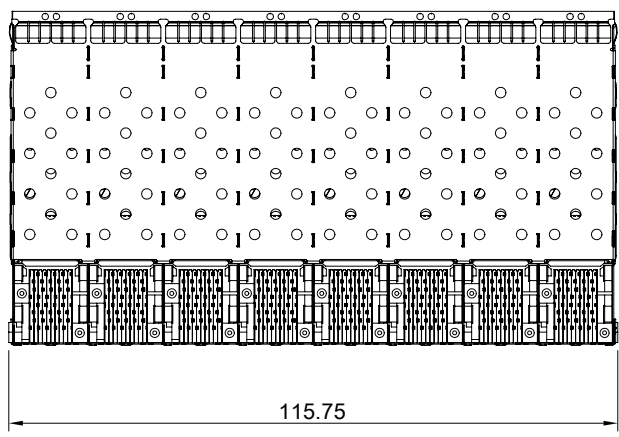
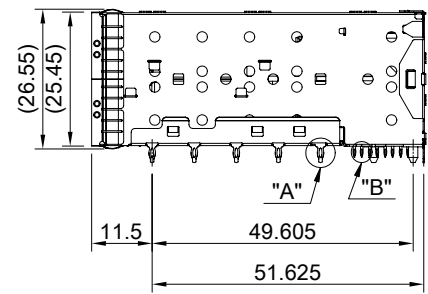
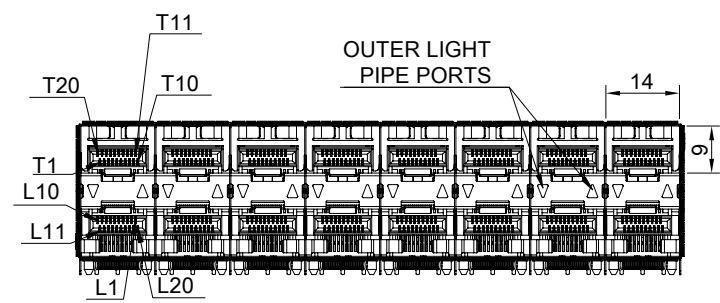
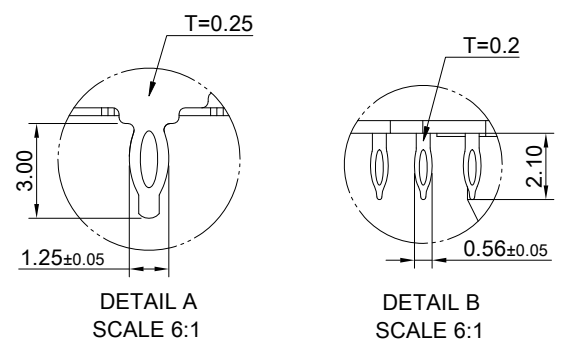
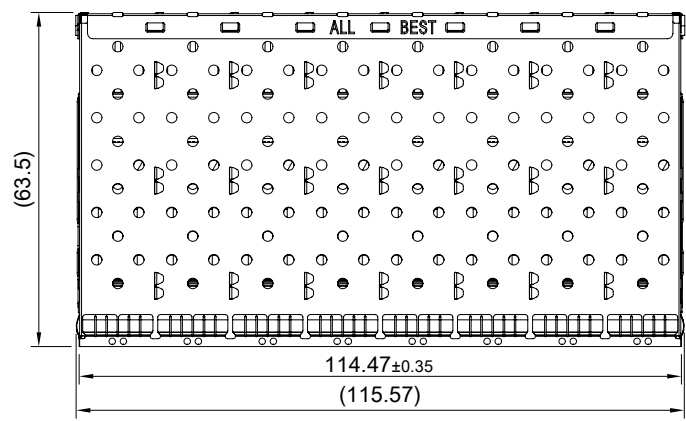

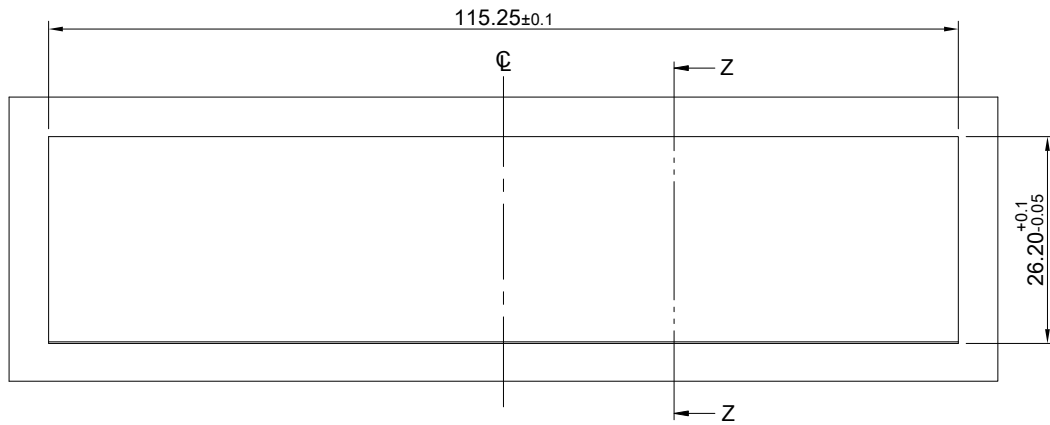

RECOMMENDED BEZEL CUT-OUT SPACING DETAIL
BEZEL THICKNESS 0.8-2.6MM

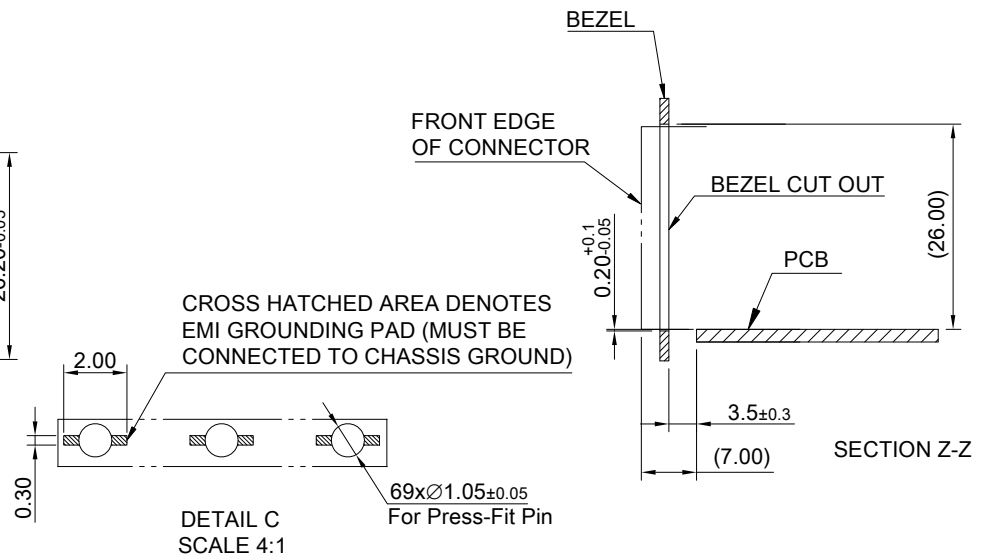

DETAIL C
SCALE 4:1

SECTION Z-Z

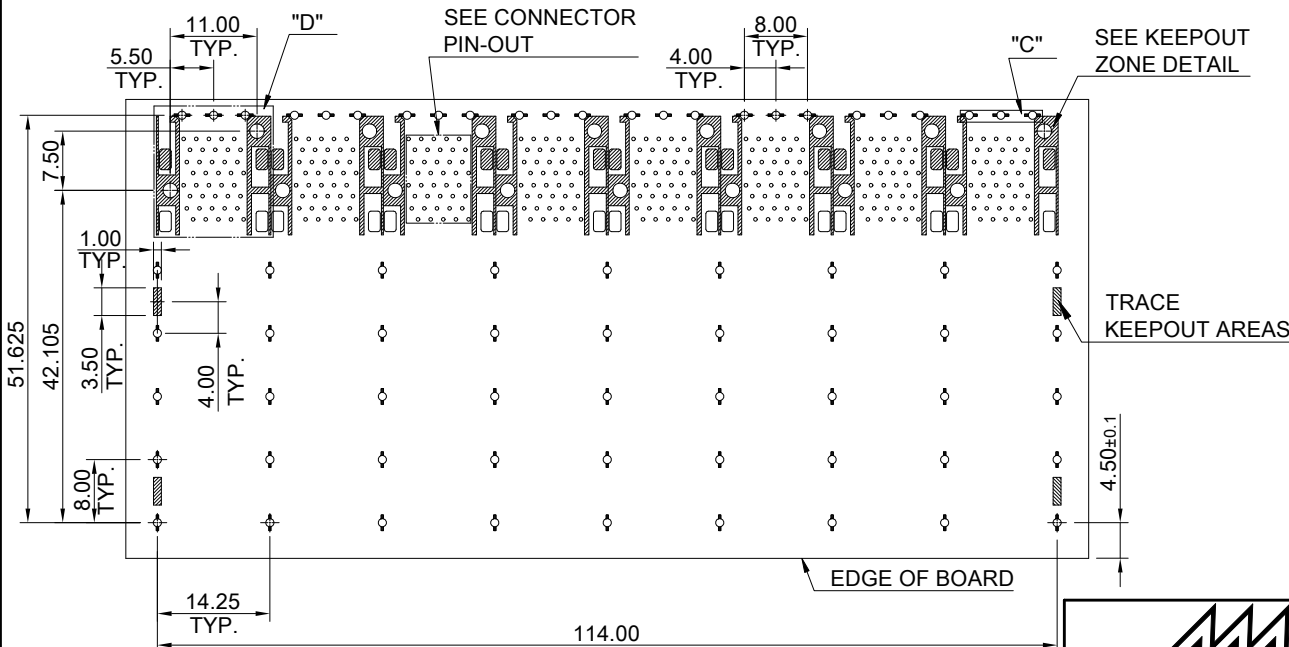

RECOMMENDED PCB LAYOUT-COMPONENT SIDE
TOLERANCE: ± 0.05
RECOMMENDED PCB THICKNESS- 1.57 MM
THE ENTIRE AREA OF THE KEEP-OUT AREA FOR
COMPONENTS
(OTHER THAN LIGHT PIPE LED'S)
THIS AREA IS INDICATED BY THE DASHED LINE

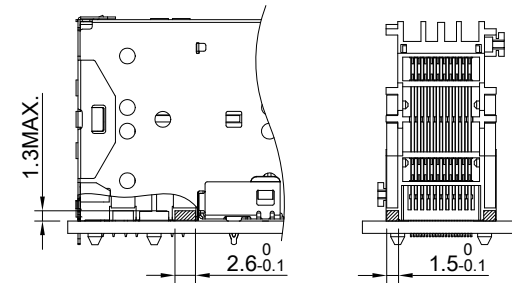

LED CLEARANCE REQUIREMENTS

THIS PRINT IS
PRELIMINARY
UNQUALIFIED PRODUCT
CONTACT PRODUCT ENGINEERING
BEFORE USING THIS PRINT

	TITLE: Stacked SFP+ 2X8 ASS'Y w/ Internal Thermal Solution & Light Pipe			SHEET: 2/3		REV. REF
	DWG#: R-OP-008320-7P-F-N2-58			CHECKED:		
UNIT: mm	SCALE: A4 1:1	FINISH:		APPROVED:		
THIRD ANGLE PROJECTION		MATERIAL: RoHS Compliant		DATE: 03/28/2024		
TOLERANCE: Angle: $\pm 1^\circ$		DRAWN: Laura				
X ± 0.15 .X ± 0.10 .XX ± 0.05						

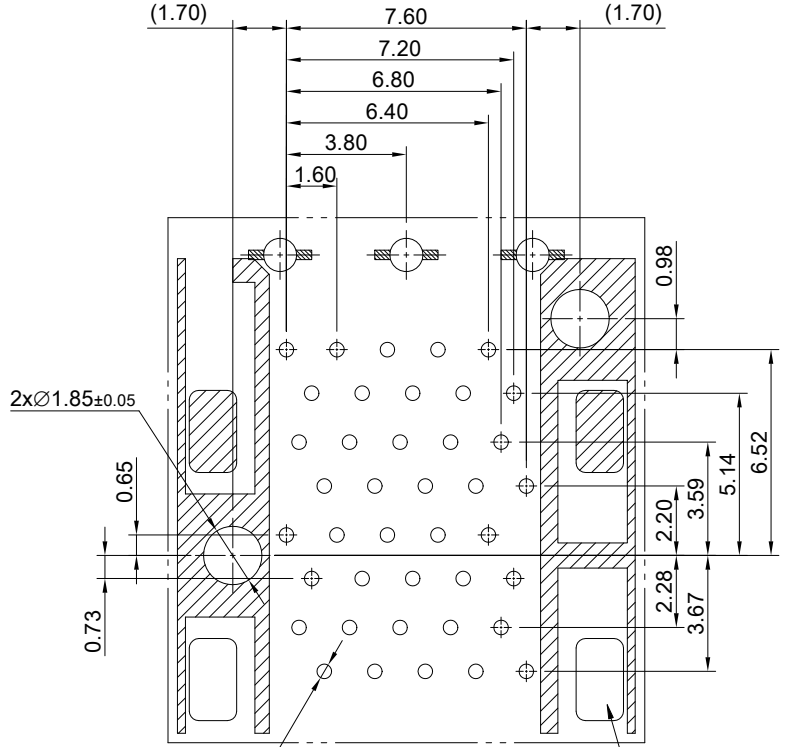
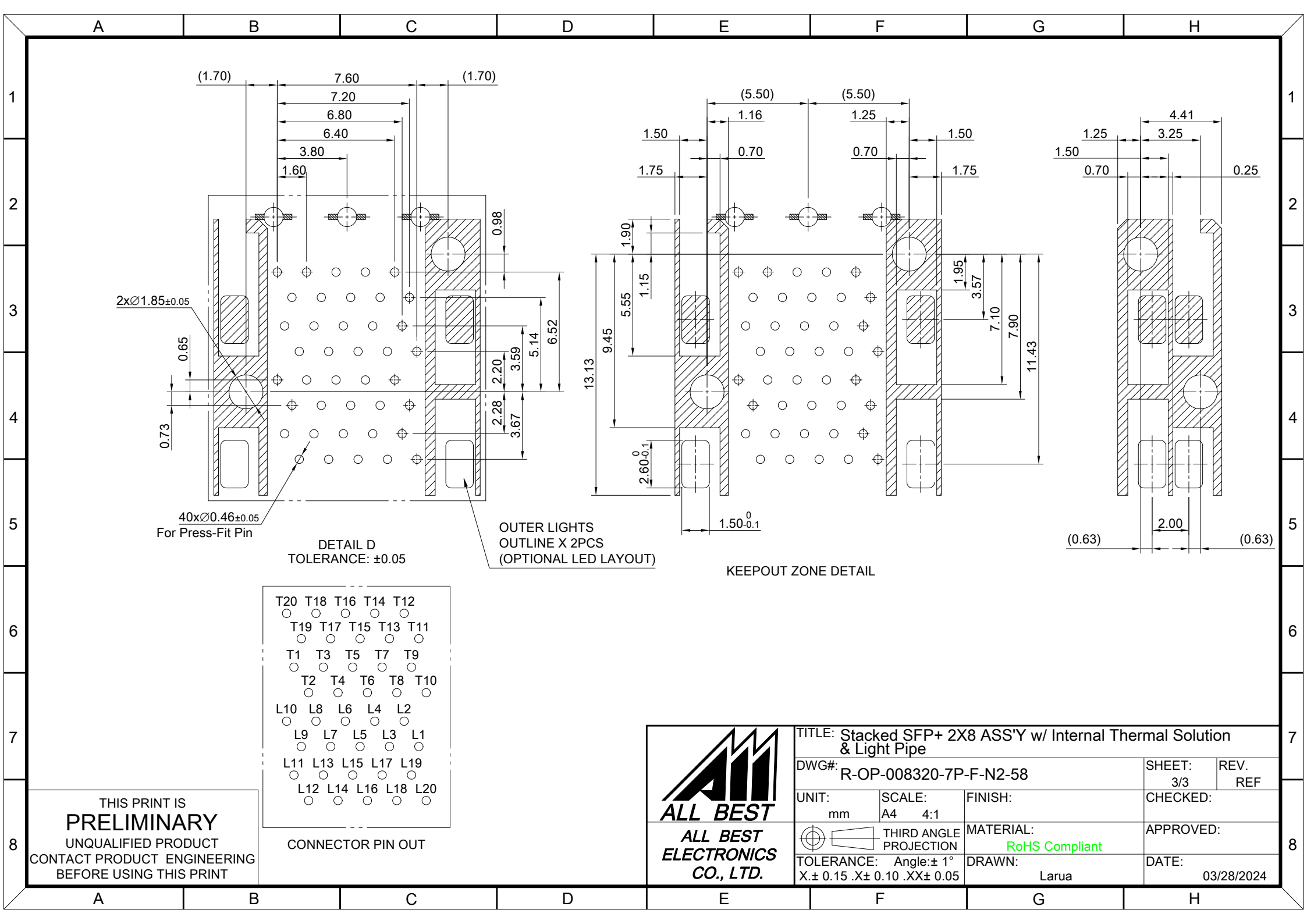

40xØ0.46±0.05
For Press-Fit Pin

DETAIL D
TOLERANCE: ±0.05

OUTER LIGHTS
OUTLINE X 2PCS
(OPTIONAL LED LAYOUT)

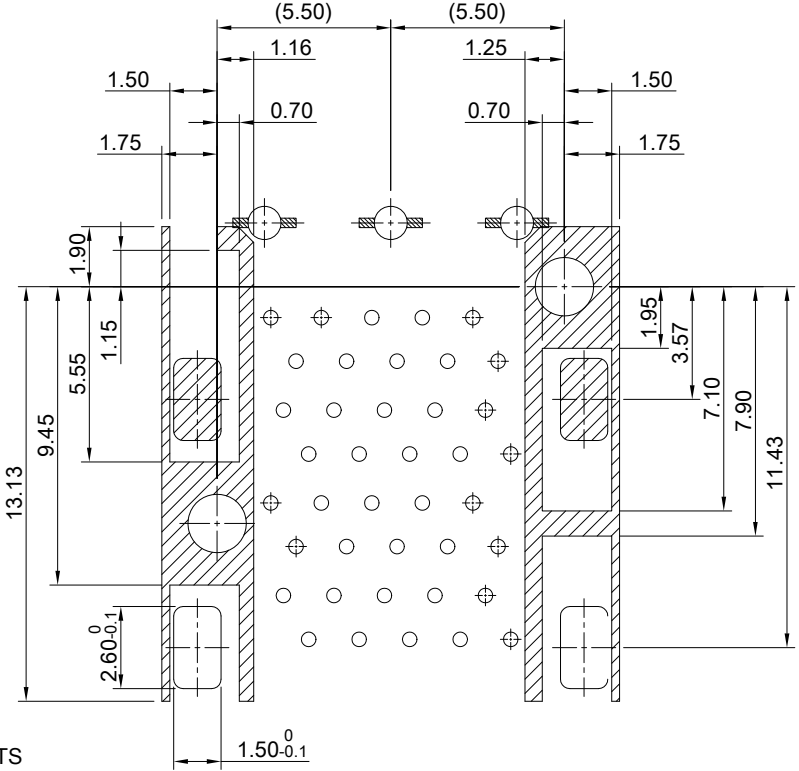

KEEPOUT ZONE DETAIL

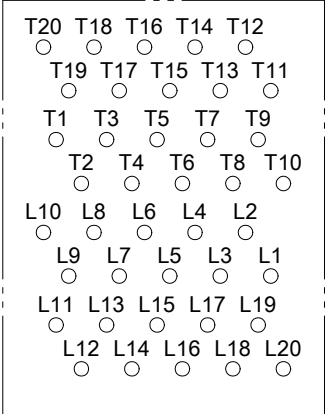
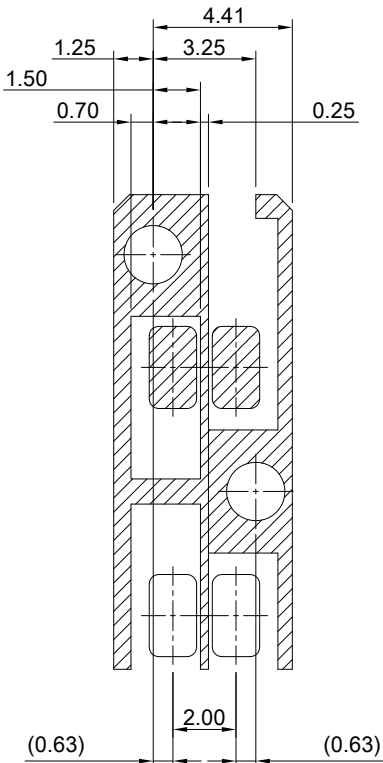

CONNECTOR PIN OUT

THIS PRINT IS
PRELIMINARY
UNQUALIFIED PRODUCT
CONTACT PRODUCT ENGINEERING
BEFORE USING THIS PRINT



TITLE: Stacked SFP+ 2X8 ASS'Y w/ Internal Thermal Solution & Light Pipe			
DWG#: R-OP-008320-7P-F-N2-58		SHEET: 3/3	REV. REF
UNIT: mm	SCALE: A4 4:1	FINISH:	CHECKED:
TOLERANCE: Angle: ± 1° X.± 0.15 .X± 0.10 .XX± 0.05		MATERIAL: RoHS Compliant	APPROVED:
THIRD ANGLE PROJECTION		DRAWN: Larua	DATE: 03/28/2024