

DETAIL A  
SCALE 4:1

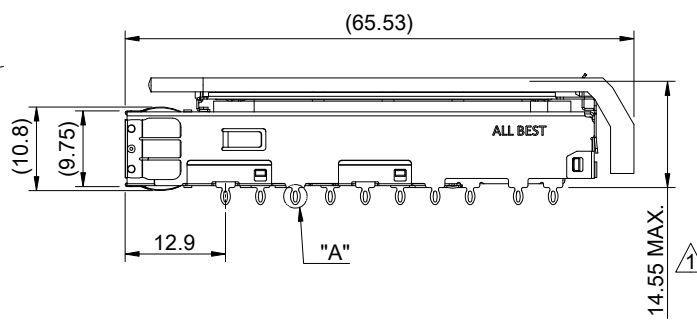
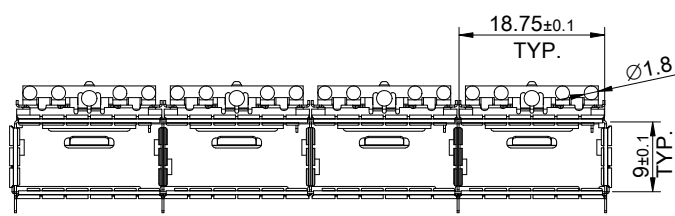
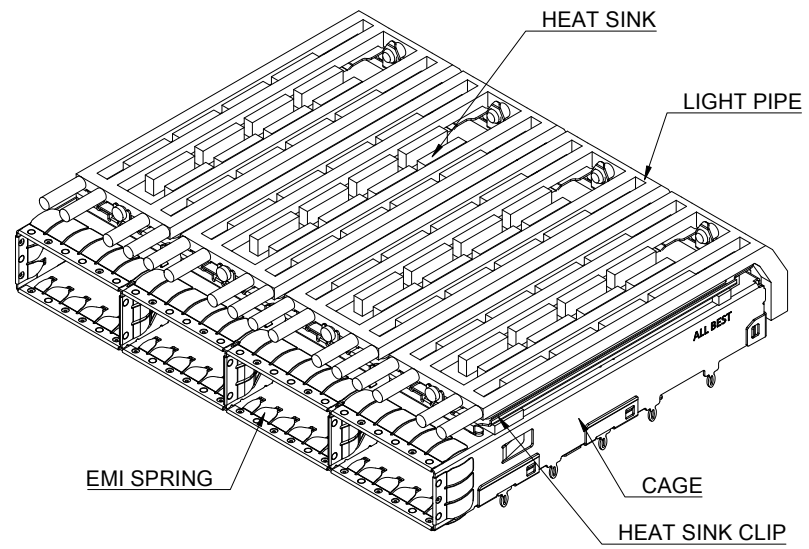

MATERIAL  
 CAGE: NICKEL SILVER  
 HEAT SINK: ALUMINUM  
 HEAT SINK CLIP: STAINLESS STEEL  
 EMI SPRING: STAINLESS STEEL  
 LIGHT PIPE: PC

FINISH  
 HEAT SINK: ANODE PROCESS

NOTE  
 ▲ DIMENSION APPLIES WITH MODULE INSERTED IN CAGE

THIS PRINT IS  
**PRELIMINARY**  
 UNQUALIFIED PRODUCT  
 CONTACT PRODUCT ENGINEERING  
 BEFORE USING THIS PRINT



TITLE: QSFP28 1X4 Cage w/ Heat Sink (PCI) & Light Pipe			
DWG#: R-OR-ZQ4-4CMEG-MK		SHEET: 1/4	REV. REF
UNIT: mm	SCALE: A4 1:1	CHECKED:	
THIRD ANGLE PROJECTION		APPROVED:	
TOLERANCE: Angle: ± 1°		MATERIAL: RoHS Compliant	DATE: 03/25/2024
X± 0.25 .X± 0.20 .XX± 0.15		DRAWN: Gary	

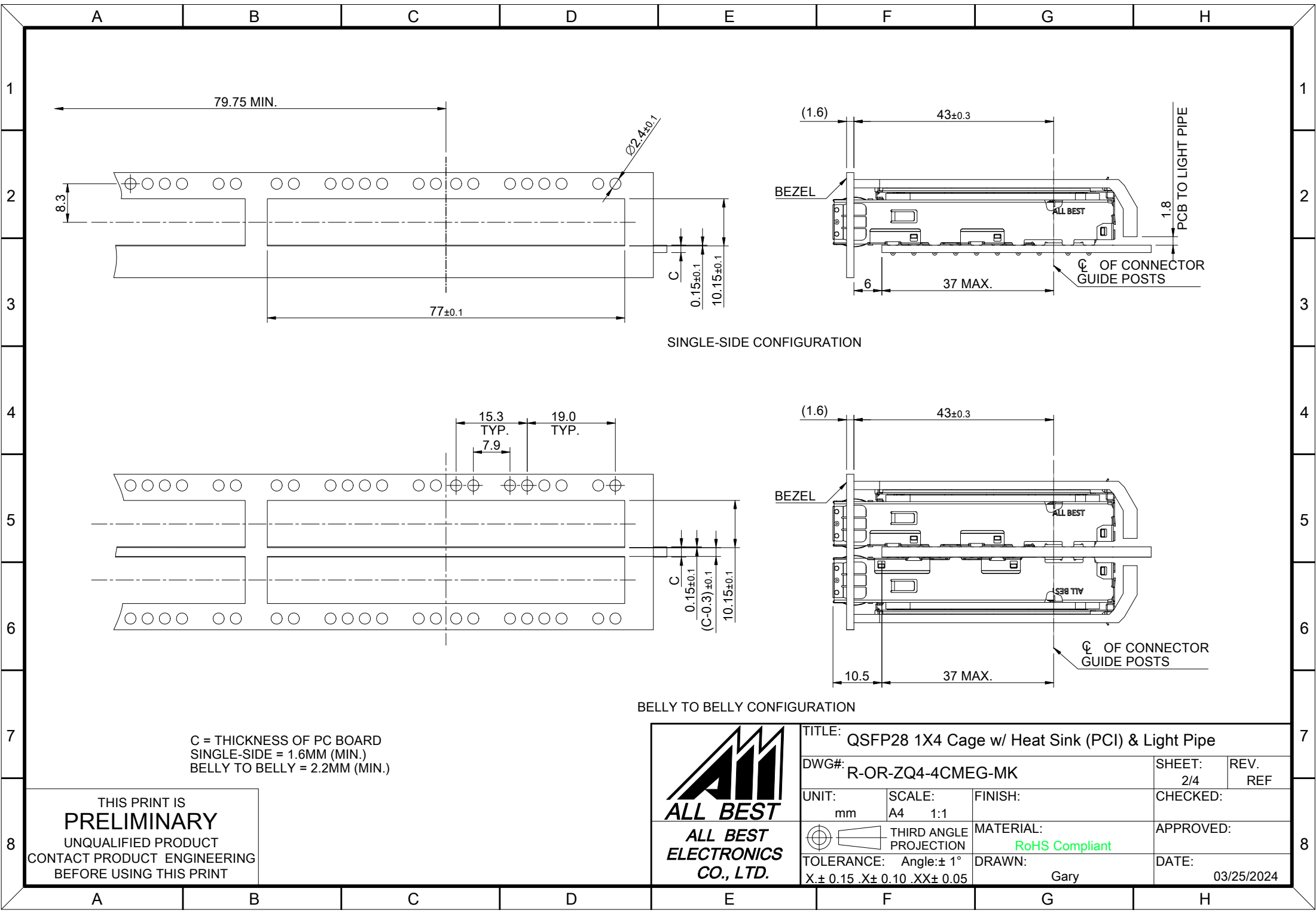

SINGLE-SIDE CONFIGURATION

BELLY TO BELLY CONFIGURATION

C = THICKNESS OF PC BOARD  
 SINGLE-SIDE = 1.6MM (MIN.)  
 BELLY TO BELLY = 2.2MM (MIN.)

THIS PRINT IS  
**PRELIMINARY**  
 UNQUALIFIED PRODUCT  
 CONTACT PRODUCT ENGINEERING  
 BEFORE USING THIS PRINT



TITLE: QSFP28 1X4 Cage w/ Heat Sink (PCI) & Light Pipe			
DWG#: R-OR-ZQ4-4CMEG-MK		SHEET: 2/4	REV. REF
UNIT: mm	SCALE: A4 1:1	FINISH:	CHECKED:
THIRD ANGLE PROJECTION		MATERIAL: RoHS Compliant	APPROVED:
TOLERANCE: Angle: ± 1°		DRAWN: Gary	DATE: 03/25/2024
X ± 0.15 .X ± 0.10 .XX ± 0.05			

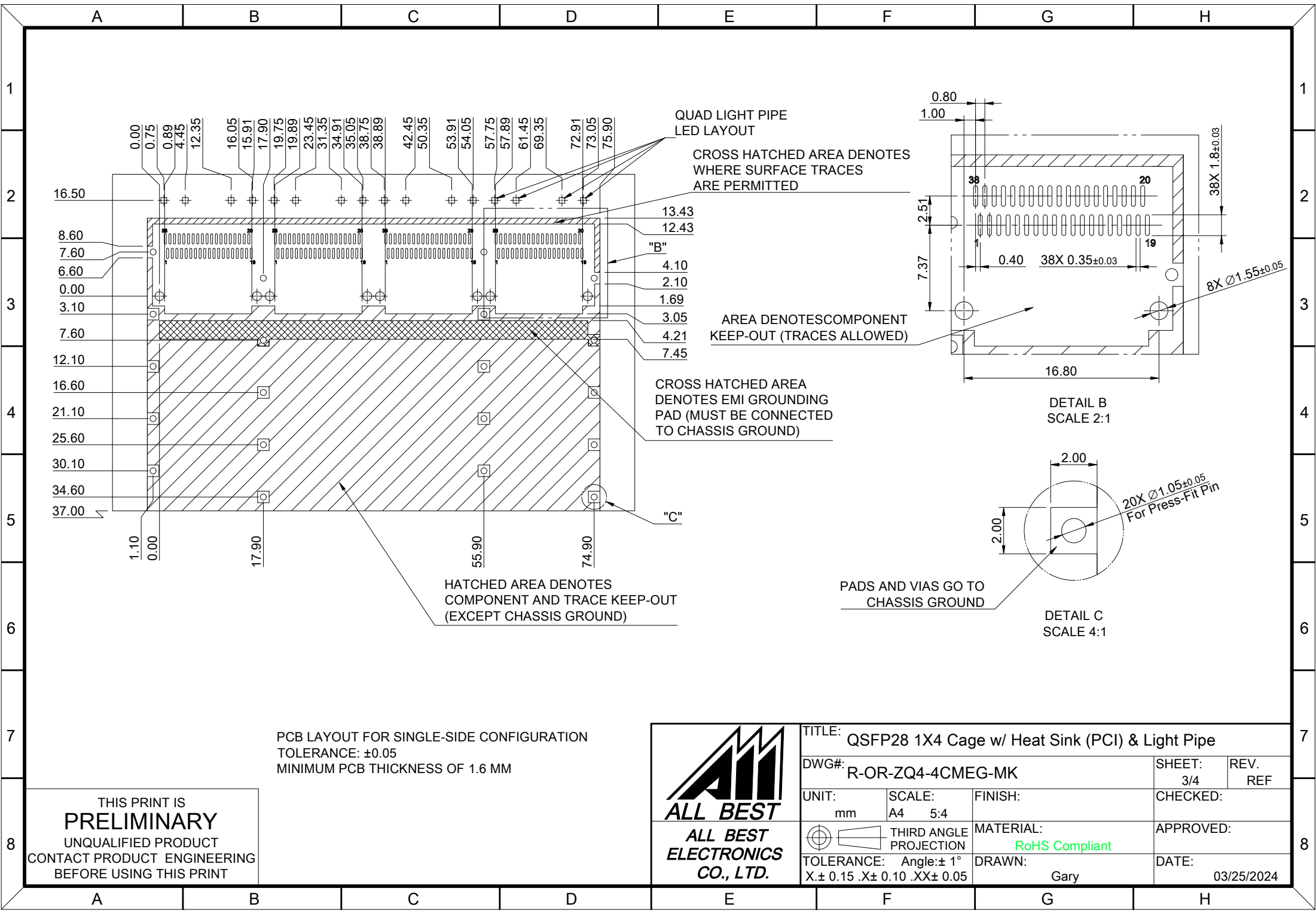

PCB LAYOUT FOR SINGLE-SIDE CONFIGURATION  
 TOLERANCE: ±0.05  
 MINIMUM PCB THICKNESS OF 1.6 MM

THIS PRINT IS  
**PRELIMINARY**  
 UNQUALIFIED PRODUCT  
 CONTACT PRODUCT ENGINEERING  
 BEFORE USING THIS PRINT



TITLE: QSFP28 1X4 Cage w/ Heat Sink (PCI) & Light Pipe			
DWG#: R-OR-ZQ4-4CMEG-MK		SHEET: 3/4	REV. REF
UNIT: mm	SCALE: A4 5:4	FINISH:	CHECKED:
THIRD ANGLE PROJECTION		MATERIAL: RoHS Compliant	APPROVED:
TOLERANCE: Angle: ± 1° X: ± 0.15 .X: ± 0.10 .XX: ± 0.05		DRAWN: Gary	DATE: 03/25/2024

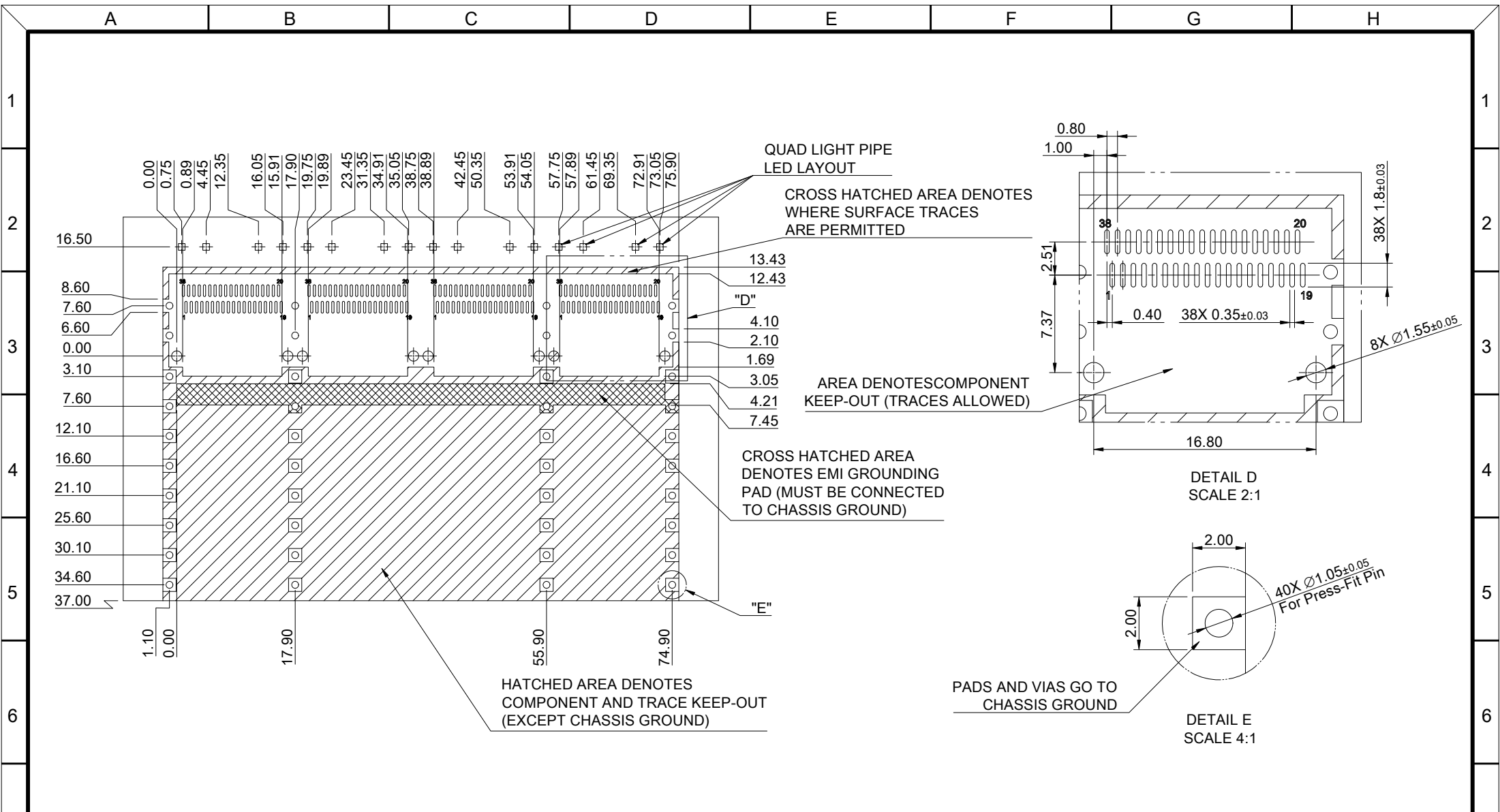

PCB LAYOUT FOR BELLY TO BELLY CONFIGURATION  
 TOLERANCE: ±0.05  
 MINIMUM PCB THICKNESS OF 2.2 MM

THIS PRINT IS  
**PRELIMINARY**  
 UNQUALIFIED PRODUCT  
 CONTACT PRODUCT ENGINEERING  
 BEFORE USING THIS PRINT



TITLE: QSFP28 1X4 Cage w/ Heat Sink (PCI) & Light Pipe			
DWG#: R-OR-ZQ4-4CMEG-MK		SHEET: 4/4	REV. REF
UNIT: mm	SCALE: A4 5:4	FINISH:	CHECKED:
TOLERANCE: Angle: ± 1° X ± 0.15 .X ± 0.10 .XX ± 0.05		MATERIAL: RoHS Compliant	APPROVED:
THIRD ANGLE PROJECTION		DRAWN: Gary	DATE: 03/25/2024